



INSTRUCTIONS FOR 1100W 230V 210mm Mitre Saw

Stock No.21307

Part No.MS210C

IMPORTANT: PLEASE READ THESE INSTRUCTIONS CAREFULLY TO ENSURE THE SAFE AND EFFECTIVE USE OF THIS PRODUCT.



GENERAL INFORMATION

These instructions accompanying the product are the original instructions. This document is part of the product, keep it for the life of the product passing it on to any subsequent holder of the product. Read all these instructions before assembling, operating or maintaining this product.

This manual has been compiled by Draper Tools describing the purpose for which the product has been designed, and contains all the necessary information to ensure its correct and safe use. By following all the general safety instructions contained in this manual, it will ensure both product and operator safety, together with longer life of the product itself.

All photographs and drawings in this manual are supplied by Draper Tools to help illustrate the operation of the product.

Whilst every effort has been made to ensure the accuracy of information contained in this manual, the Draper Tools policy of continuous improvement determines the right to make modifications without prior warning.

1. TITLE PAGE

1.1 INTRODUCTION:

USER MANUAL FOR:

1100W 230V 210MM MITRE SAW

Stock no. 21307.

Part no. MS210C

1.2 REVISIONS:

Date first published August 2016

As our user manuals are continually updated, users should make sure that they use the very latest version.

Downloads are available from: <http://www.drapertools.com/manuals.pgm>

DRAPER TOOLS LIMITED

HURSLEY ROAD

CHANDLER'S FORD

EASTLEIGH

HAMPSHIRE

SO53 1YF

UK

WEBSITE: drapertools.com

PRODUCT HELPLINE: +44 (0) 23 8049 4344

GENERAL FAX: +44 (0) 23 8026 0784

1.3 UNDERSTANDING THIS MANUALS SAFETY CONTENT:

WARNING! Information that draws attention to the risk of injury or death.

CAUTION! Information that draws attention to the risk of damage to the product or surroundings.

1.4 COPYRIGHT © NOTICE:

Copyright © Draper Tools Limited.

Permission is granted to reproduce this publication for personal & educational use only.

Commercial copying, redistribution, hiring or lending is prohibited.

No part of this publication may be stored in a retrieval system or transmitted in any other form or means without written permission from Draper Tools Limited.

In all cases this copyright notice must remain intact.

2. CONTENTS

2.1 CONTENTS

	PAGE CONTENT	PAGE
1	TITLE PAGE	
	1.1 INTRODUCTION	2
	1.2 REVISION HISTORY	2
	1.3 UNDERSTANDING THIS MANUAL	2
	1.4 COPYRIGHT NOTICE	2
2	CONTENTS	
	2.1 CONTENTS	3
3	GUARANTEE	
	3.1 GUARANTEE	4
4	INTRODUCTION	
	4.1 SCOPE	5
	4.2 SPECIFICATION	5
	4.3 HANDLING & STORAGE	5
5.	HEALTH & SAFETY INFORMATION	
	5.1 GENERAL SAFETY INSTRUCTIONS FOR POWER TOOL USE	6-7
	5.2 ADDITIONAL SAFETY INSTRUCTIONS FOR MITRE SAWS	8
	5.3 ADDITIONAL SAFETY INSTRUCTIONS FOR CIRCULAR SAW BLADES	9
	5.4 CAUTION: RISK OF ELECTRIC SHOCK. DO NOT OPEN.	10
6.	TECHNICAL DESCRIPTION	
	6.1 IDENTIFICATION	11
7.	UNPACKING & CHECKING	
	7.1 PACKAGING	12
	7.2 WHAT'S IN THE BOX?	12
8.	PREPARING THE MITRE SAW	
	8.1 BENCH MOUNTING	13
	8.2 WORKPIECE VICE	13
	8.3 BASE STABILISER	13
	8.4 SAW HEAD LOCKING PIN	14
	8.5 MITRE LOCKING ASSEMBLY	14
	8.6 PLUNGE RELEASE LEVER	14
	8.7 DUST EXTRACTION	15
	8.8 DEPTH OF CUT STOP	15
	8.9 BEVEL ADJUSTMENT	15
	8.10 CHECKING THE TABLE TO BLADE ALIGNMENT	16
	8.11 CHECK THE FENCE TO BLADE ALIGNMENT	17
	8.12 TABLE INSERT REPLACEMENT	17
	8.13 BLADE REPLACEMENT	18
	8.14 BASIC SAW OPERATIONS	18
	8.15 BODY AND HAND POSITION	18
9.	OPERATING THE MITRE SAW	
	9.1 MITRE CUT	19
	9.2 BEVEL CUT	19
	9.3 COMPOUND CUT	19
	9.4 CUTTING CURVED OR WARPED MATERIAL	20
	9.5 WORKPIECE SUPPORT	21
10.	GLOSSARY OF TERMS FOR WOODWORKING	22
11.	MAINTENANCE	23
12.	TROUBLESHOOTING	24
13.	OPTIONAL ACCESSORIES	
	13.1 OPTIONAL ACCESSORIES	25
14.	EXPLANATION OF SYMBOLS	
	14.1 EXPLANATION OF SYMBOLS	26
15.	DISPOSAL	
	15.1 DISPOSAL	27
	DECLARATION OF CONFORMITY	ENCLOSED

3. GUARANTEE

3.1 GUARANTEE

Draper tools have been carefully tested and inspected before shipment and are guaranteed to be free from defective materials and workmanship.

Should the tool develop a fault, please return the complete tool to your nearest distributor or contact Draper Tools Limited, Chandler's Ford, Eastleigh, Hampshire, SO53 1YF. England. Telephone Sales Desk: (023) 8049 4333 or Product Helpline (023) 8049 4344.

A proof of purchase must be provided with the tool.

If upon inspection it is found that the fault occurring is due to defective materials or workmanship, repairs will be carried out free of charge. This guarantee period covering parts/labour is 12 months from the date of purchase except where tools are hired out when the guarantee period is 90 days from the date of purchase. The guarantee is extended to 24 months for parts only. This guarantee does not apply to normal wear and tear, nor does it cover any damage caused by misuse, careless or unsafe handling, alterations, accidents, or repairs attempted or made by any personnel other than the authorised Draper warranty repair agent.

Note: If the tool is found not to be within the terms of warranty, repairs and carriage charges will be quoted and made accordingly.

This guarantee applies in lieu of any other guarantee expressed or implied and variations of its terms are not authorised.

Your Draper guarantee is not effective unless you can produce upon request a dated receipt or invoice to verify your proof of purchase within the guarantee period.

Please note that this guarantee is an additional benefit and does not affect your statutory rights.

Draper Tools Limited.

4. INTRODUCTION

4.1 SCOPE

This machine is designed to cut wood.
Any other application is considered mis-use.

4.2 SPECIFICATION

Stock no	21307
Part no	MS210C
Motor:	
Rated voltage	230V~
Rated frequency	50Hz
Rated input	1100W
Revolutions per minute (no load)	5500min ⁻¹
Blade diameter	210mm
Blade thickness	2.4mm
Bore diameter	30mm
Mitre table angles	0-45°
Bevel cut	0-45°
Straight cut	Mitre 0° x Bevel 0° 60 x 120mm
Mitre cut	Mitre 45° x Bevel 0° 60 x 80mm
Bevel cut	Bevel 45° x Mitre 0° 33 x 120mm
Compound mitre cut	Bevel 45° x Mitre 45° 33 x 80mm
Sound pressure level	95.26dB(A)
Sound power level	108.26dB(A)
Weight (nett)	6.4kg

4.3 HANDLING & STORAGE

Although this machine is small in size, care must still be taken when handling and lifting. Dropping this machine will have an effect on the accuracy and may also result in personal injury. This machine is not a toy and must be respected.

The environment will have a negative result on its operation if you are not careful. If the air is damp, components will rust. If the machine is unprotected from dust and debris; components will become clogged: And if not cleaned and maintained correctly or regularly the machine will not perform at its best.

5. HEALTH & SAFETY INFORMATION

5.1 GENERAL SAFETY INSTRUCTIONS FOR POWER TOOL USE

When using any type of power tool there are steps that should be taken to make sure that you, as the user, remain safe.

Common sense and a respect for the tool will help reduce the risk of injury.

Read the instruction manual fully. Do not attempt any operation until you have read and understood this manual.

Most important you must know how to safely start and stop this machine, especially in an emergency.

Keep the work area tidy and clean. Attempting to clear clutter from around the machine during use will reduce your concentration. Mess on the floor creates a trip hazard. Any liquid spilt on the floor could result in you slipping.

Find a suitable location. If the machine is bench mounted; the location should provide good natural light or artificial lighting as a replacement. Avoid damp and dusty locations as it will have a negative effect on the machine's performance.

If the machine is portable; do not expose the tool to rain. In all cases do not operate power tools near any flammable materials.

Beware of electric shock. Avoid contact with earthed surfaces; because they can conduct electricity if there is an electrical fault with the power tool. Always protect the power cable and route it away from danger.

Keep bystanders away. Children, onlookers and passers by must be restricted from entering the work area for their own protection. The barrier must extend a suitable distance from the tool user.

Unplug and house all power tools that are not in use. A power tool should never be left unattended while connected to the power supply. They must be housed in a suitable location, away locked up and from children.

Do not overload or misuse the tool. All tools are designed for a purpose and are limited to what they are capable of doing. Do not attempt to use a power tool (or adapt it in any way) for an application it is not designed for. Select a tool appropriate for the size of the job. Overloading a tool will result in tool failure and user injury: This covers the use of accessories.

Dress properly. Loose clothing, long hair and jewellery are all dangerous because they can become entangled in moving machinery: This can also result in parts of body being pulled into the machine.

Clothing should be close fitted, with any long hair tied back and jewellery and neck ties removed. Footwear must be fully enclosed and have a nonslip sole.

5. HEALTH & SAFETY INFORMATION

Wear personal protective equipment (PPE). Dust, noise, vibration and swarf can all be dangerous if not suitably protected against. If the work involving the power tool creates dust or fumes; wear a dust mask. Vibration to the hand, caused by operating some tools for longer periods must be protected against. Wear vibration reducing gloves and allow long breaks between uses. Protect against dust and swarf by wearing approved safety goggles or a face shield. These are some of the more common hazards and preventions; however, always find out what hazards are associated with the machine/work process and wear the most suitable protective equipment available.

Do not breathe contaminated air. If the work creates dust or fumes; connect the machine (if possible) to an extraction system either locally or remotely. Working outdoors can also help if possible.

Move the machine as instructed. If the machine is hand held, do not carry it by the power supply cable. If the product is heavy; employ a second or third person to help move it safely or use a mechanical device. Always refer to the instructions for the correct method.

Do not overreach. Extending your body too far can result in a loss of balance and you falling. This could be from a height or onto a machine and will result in injury.

Maintain your tools correctly. A well maintained tool will do the job safely. Replace any damaged or missing parts immediately with original parts from the manufacturer. As applicable; keep blades sharp; moving parts clean, oiled or greased; handles clean; and emergency devices working.

Wait for the machine to stop. Unless the machine is fitted with a safety brake; some parts may continue to move due to momentum. Wait for all parts to stop; then unplug it from the power supply before making any adjustments, carrying out maintenance operations or just finishing using the tool.

Remove and check setting tools. Some machinery requires the use of additional tools or keys to set, load or adjust the power tool. Before starting the power tool always check to make certain they have been removed and are safely away from the machine.

Prevent unintentional starting. Before plugging any machine in to the power supply, make sure the switch is in the OFF position. If the machine is portable; do not hold the machine near the switch and take care when putting the machine down; that nothing can operate the switch.

Carefully select an extension lead. Some machines are not suitable for use with extension leads. If the tool is designed for use outdoors; use an extension lead also suitable for that environment. When using an extended lead, select one capable of handling the current (amps) drawn by the machine in use. Fully extend the lead regardless of the distance between the power supply and the tool. Excess current (amps) and a coiled extension lead will both cause the cable to heat up and can result in fire.

Concentrate and stay alert. Distractions are likely to cause an accident. Never operate a power tool if you are under the influence of drugs (prescription or otherwise), including alcohol or if you are feeling tired. Being disorientated will result in an accident.

5. HEALTH & SAFETY INFORMATION

Have this tool repaired by a qualified person. This tool is designed to conform to the relevant international and local standards and as such should be maintained and repaired by someone qualified; using only original parts supplied by the manufacturer: This will ensure the tool remains safe to use.

5.2 ADDITIONAL SAFETY INSTRUCTIONS FOR MITRE SAWS

SAFETY PRECAUTIONS

- Do not use saw blades which are damaged or deformed.
- Replace the table insert when worn.
- Use only saw blades recommended by the manufacturer which conform to EN 847-1;
- Do not use saw blades manufactured from high speed steel;
- Wear suitable personal protective equipment when necessary, which should include:
 - Hearing protection to reduce the risk of induced hearing loss;
 - Eye protection;
 - Respiratory protection to reduce the risk of inhalation of harmful dust;
 - Gloves for handling saw blades (saw blades shall be carried in a holder wherever practicable) and rough material;
- Connect the saw to a dust collecting device when sawing wood.

Maintenance and servicing

- Report faults in the machine, including guards or saw blades, as soon as they are discovered.

Safe operation

- Select the correct saw blade for the material to be cut;
- Do not use the saw to cut other materials than those recommended by the manufacturer;
- Lifting and transportation information: Ensure the mitre, bevel and lateral sliding facilities are locked in the 0°, 0° and midway positions respectively. Remove the plug from the socket and lock the saw head in the down position before attempting to move the mitre saw. Only lift/move the saw by the transportation handle.

WARNING: Do not use any other part of the saw, in particular the guards for this purpose.

- Do not use the saw without the guards in position, in good working order and properly maintained;
- Ensure that the arm is securely fixed when bevelling;
- Keep the floor area around the machine level, well maintained and free of loose materials e.g. chips and cut-offs;
- Provide adequate general or localised lighting;
- Ensure the operator is adequately trained in the use, adjustment and operation of the machine;
- Use correctly sharpened saw blades. Observe the maximum speed marked on the saw blade;
- Ensure that any spacers and spindle rings used are suitable for the purpose as stated by the manufacturer;
- When fitted with laser, no exchange with different type of laser is permitted. Repairs shall only be carried out by the laser manufacturer or an authorised agent;
- Refrain from removing any cut-offs or other parts of the workpiece from the cutting area whilst the machine is running and the saw head is not in the rest position;
- Ensure that the machine is always fixed to a bench, whenever possible.

5. HEALTH & SAFETY INFORMATION

5.3 ADDITIONAL SAFETY INSTRUCTIONS FOR CIRCULAR SAW BLADES

Safe Working Practice

Maximum speed

- The maximum speed marked on the tool shall not be exceeded. Where stated, the speed range shall be adhered to.

Circular saw blades

- Circular saw blades, the bodies of which are cracked, shall be scrapped (repairing is not permitted).
- Composite (tipped) circular saw blades, where the tip dimension is reduced to less than 1mm, shall be taken out of service.

One piece tools

- Tools with visible cracks shall not be used.

Fastening of tools and tool parts

- Tools and tool bodies shall be clamped in such a way that they shall not loosen during operation.
- For tools with friction lock the positioning aid or setting gauge provided by the manufacturer shall be used to maintain radial and axial cutter projections.
- Care shall be taken when mounting tools to ensure that the clamping is by the hub of the tool and that the cutting edges are not in contact with each other or with the clamping elements.

Fastening screws and nuts shall be tightened using the appropriate spanners, etc., and to the torque value provided by the manufacturer.

- Extension of the spanner or tightening using hammer blows shall not be permitted.
- Clamping surfaces shall be cleaned to remove dirt, grease, oil and water.
- Clamping screws shall be tightened according to instructions provided by the manufacturer. Where instructions are not provided, clamping screws shall be tightened in sequence from the centre outwards.
- Use of loose rings or bushes to "make up" bore sizes on circular saw blades shall not be permitted.
- Use of fixed rings, e.g. pressed or held by adhesive fixing, in circular saw blades or flanged bushes for other tools shall be permitted if made to the manufacturers specification.
- Resin shall only be removed from light alloys with solvents that do not affect the mechanical characteristics of these materials.

Repair of tools

- Repair of tools is only allowed according to the tool manufacturers instructions. Particular attention is drawn to the following.
- The design of composite (tipped) tools shall not be changed in the process of repair.
- Composite tools shall be repaired by a competent person, i.e. a person of training and experience, who has knowledge of the design requirements and understands the levels of safety to be achieved.
- Repair shall therefore include, e.g. use of spare parts which are in accordance with the specification of the original parts provided by the manufacturer.
- Tolerances which ensure correct clamping shall be maintained.
- For one piece tools care shall be taken that regrinding of the cutting edge will not cause weakening of the hub and the connection of the cutting edge to the hub.

5. HEALTH & SAFETY INFORMATION

5.5 CAUTION: RISK OF ELECTRIC SHOCK. DO NOT OPEN.

Caution: Risk of electric shock. Do not open.

This appliance is supplied with a moulded 3 pin mains plug for your safety. The value of the fuse fitted is marked on the pin face of the plug. Should the fuse need replacing, ensure the substitute is of the correct rating, approved to BS1362 and ASTA or BS Kite marked.

ASTA 

BSI 

The fuse cover is removable with a small plain slot screwdriver. Ensure the fuse cover is replaced before attempting to connect the plug to an electrical outlet. If the cover is missing, a replacement must be obtained or the plug replaced with a suitable type.

If a replacement plug is to be fitted this must be carried out by a qualified electrician.

The damaged or incomplete plug, when cut from the cable should be disabled to prevent connection to a live electrical outlet.

This appliance is Class II[†] and is designed for connection to a power supply matching that detailed on the rating label and compatible with the plug fitted.

If an extension lead is required, use an approved and compatible lead rated for this appliance.

Follow all the instruction supplied with the extension lead.

[†]Double insulated : This product requires no earth connection as supplementary insulation is applied to the basic insulation to protect against electric shock in the event of failure of the basic insulation.

Important: On products exceeding 2000W it is recommended that the power cable and/or extension cable are fully unwound before a connection is made to the power supply. However, ensure the residual cable does not pose a trip hazard

6. TECHNICAL DESCRIPTION

6.1 IDENTIFICATION

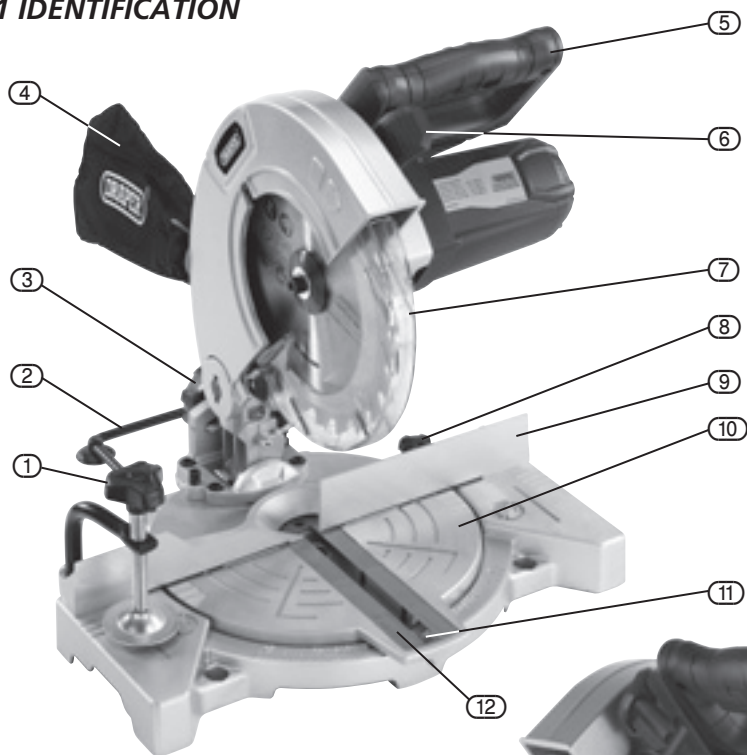

- ① Workpiece vice
- ② Base stabiliser
- ③ Bevel locking knob
- ④ Dust bag
- ⑤ Plunge handle.
- ⑥ Plunge release lever
- ⑦ Lower blade guard
- ⑧ Mitre lock knob
- ⑨ Fence
- ⑩ Table
- ⑪ Mitre pointer
- ⑫ Table insert

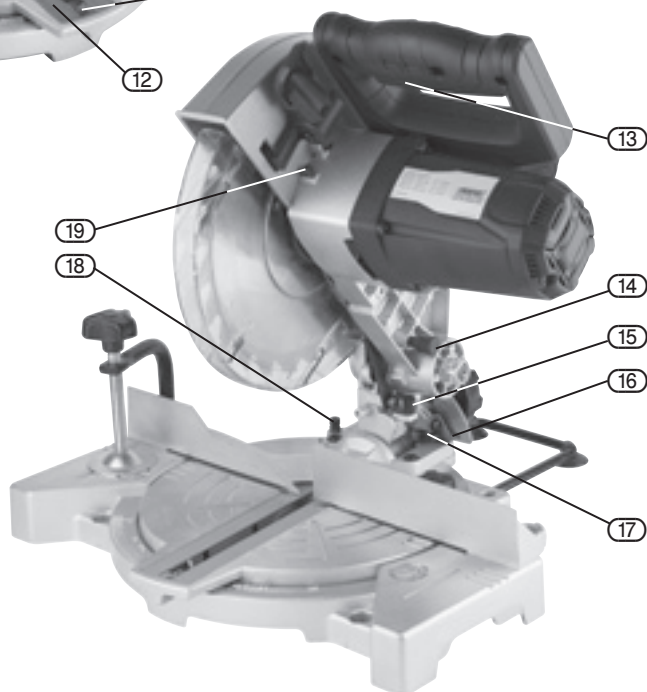

- ⑬ On/Off trigger
- ⑭ Saw head locking pin
- ⑮ Depth stop
- ⑯ Bevel pointer
- ⑰ 0° bevel stop
- ⑱ 45° bevel stop
- ⑲ Spindle lock button

7. UNPACKING & CHECKING

7.1 PACKAGING

Carefully remove the mitre saw from the packaging and examine it for any sign of damage that may have happened during shipping. Lay the contents out and check them against the parts shown below. If any part is damaged or missing; please contact the Draper Helpline (the telephone number appears on the Title page) and do not attempt to use the machine.

The packaging material should be retained at least during the guarantee period: in case the machine needs to be returned for repair.

Warning! Some of the packaging materials used may be harmful to children. Do not leave any of these materials in the reach of children.

If any of the packaging is to be thrown away, make sure they are disposed of correctly; according to local regulations.

7.2 WHAT'S IN THE BOX?

As well as the mitre saw; there are several parts not fitted or attached to it.

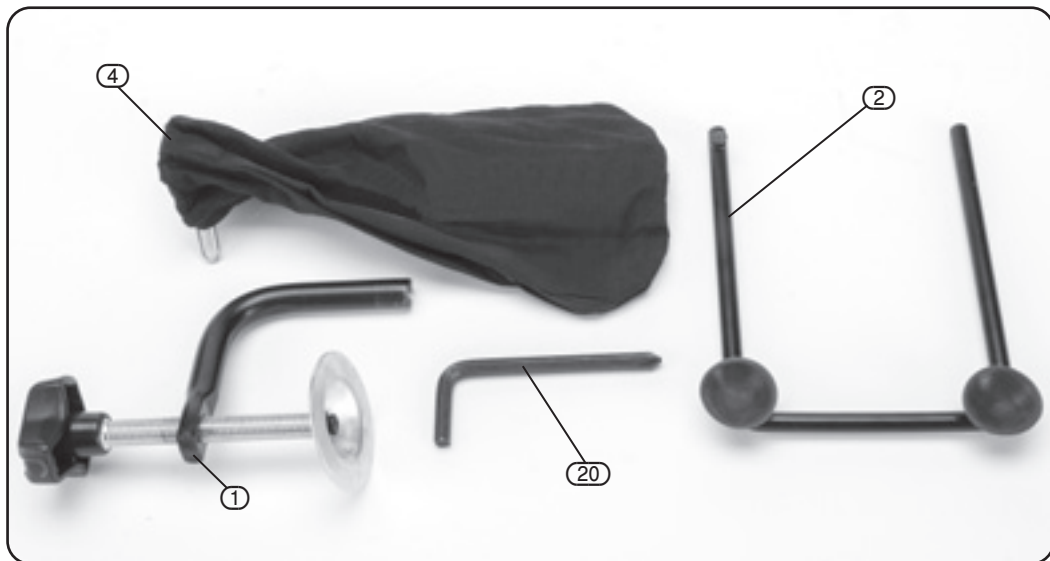

- ④ Dust bag.
- ② Base stabiliser
- ②① Hex. key/cross head driver
- ① Workpiece vice

8. PREPARING THE MITRE SAW

NOTE: Remove the plug from the socket before carrying out adjustment, servicing or maintenance.

8.1 BENCH MOUNTING

NOTE: Securing the mitre saw. For safe working practice the saw must be mounted on a secure level surface. Using the holes in the base and four suitable bolts (not supplied) to fix the saw down. Avoid mounting the saw where large workpieces will be difficult to manoeuvre or support.

8.2 WORKPIECE VICE - FIG. 1

The workpiece vice (1) can be attached either side of the table on the rear fence (1.1). Insert the rod on the appropriate side of the cutting head, and turn knob to clamp workpiece.

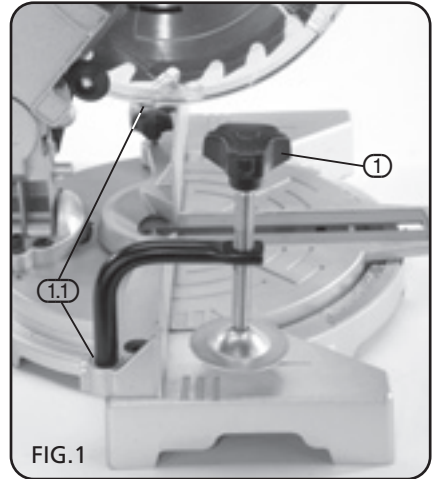

FIG.1

8.3 BASE STABILISER - FIG. 2

The stabiliser (2) is attached at the back of base, slide into holes and secure with grub screw (2.1). If the mitre saw is not bolted to worktop the stabiliser with suckers will help to keep the mitre saw stable when in use.

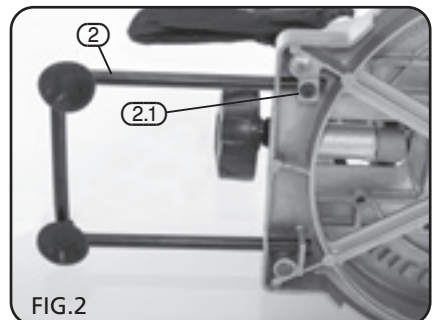

FIG.2

8. PREPARING THE MITRE SAW

8.4 SAW HEAD LOCKING PIN - FIG. 3

The saw head is locked in the down position for transport purposes and should be returned to this position when not in use. To release the saw head slightly press down on the saw head before pulling out the locking pin (14).

NOTE: The pin does not detach from the saw. The saw head can now be raised up fully. Only carry the saw with the head locked in the down position.

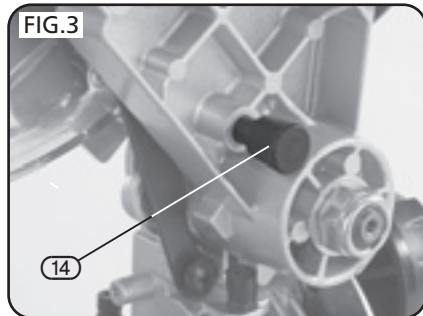

8.5 MITRE LOCKING ASSEMBLY - FIGS. 4 - 5

It is possible to set the mitre angle from 0° to 45° with preset index (10.1) set at 0°, 5°, 10°, 15°, 22.5°, 30°, 35°, 40° and 45°.

When the desired angle is set, tighten locking knob (8) to secure.

NOTE: Never make any cuts until the locking knob (8) is fully tightened.

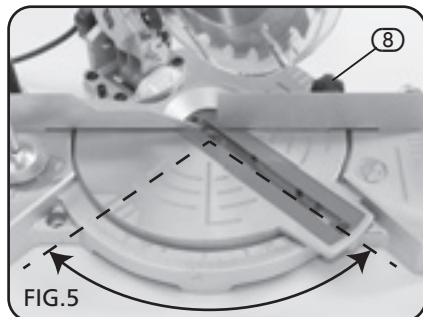
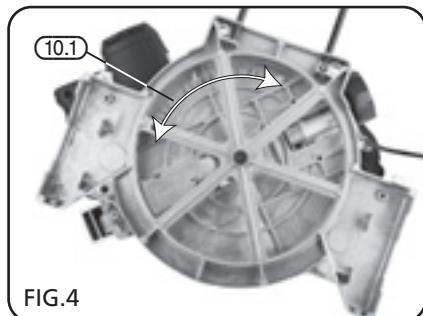

8.6 PLUNGE RELEASE LEVER - FIG. 6

As a safety feature the saw head locks in the upper position each time. To plunge the saw head operate lever (6). As the saw head lowers the lower blade guard self-retracts.



8. PREPARING THE MITRE SAW

8.7 DUST EXTRACTION - FIG. 7

The saws come supplied with a cloth dust bag (4). Pinch the spring clip (4.1) open and slide onto extraction port, release clip slowly. Empty the dust bag regularly or when full. When cutting large pieces of material or cutting for a longer period, exchange the dust bag with a dust extractor to allow more efficient removal of harmful airborne dust particles. It may be necessary to source an appropriate adaptor to adjust the dust outlet size to suit the vacuum hose.

NOTE: A dust mask must be worn for any cutting operations.

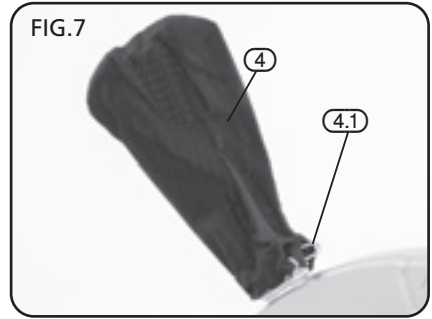

8.8 DEPTH OF CUT STOP - FIG. 8

In its normal position, the depth of cut stop (15) permits the saw blade to cut right through a workpiece. The depth adjustment screw (15.1) contacts the stop as the saw arm is lowered restricting the cut. The depth of cut can be adjusted with the adjustment screw (15.1) and locked in position with lock nut (15.2).

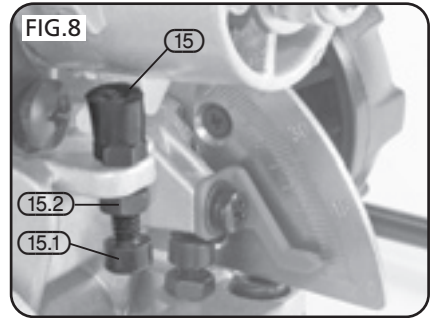

8.9 BEVEL ADJUSTMENT - FIG. 9

It is possible to set the mitre angle from 0° to 45°. Loosen lock (3) and adjust the bevel angle as indicated on scale (16.1). Tighten locking knob (3) to secure.

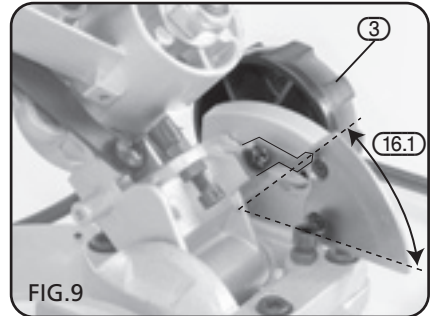

8. PREPARING THE MITRE SAW

8.10 CHECKING THE TABLE TO BLADE ALIGNMENT - FIGS. 10 - 12

NOTE: Remove the plug from the socket before carrying out adjustment, servicing or maintenance.

Lower and lock the saw head. Set the mitre and bevel angles to zero and lock. Place a small engineers square flat against the table and the blade making sure that the square contacts the flat side of the blade and not the teeth.

NOTE: The saw head may need to be unlocked and raised up slightly to accommodate the square.

The edge of the square should be parallel to the side of the blade. If any adjustment is required loosen the bevel locking knob (3). Adjust the 90° stop by turning bolt (17) then locking in position with lock nut.

If required adjust the pointer by releasing the cross head screw (16.1).

It is possible to check the 45° bevel end stop using an engineers protractor in place of the square. If necessary adjust the 45° stop by turning bolt (18) then locking in position with lock nut.

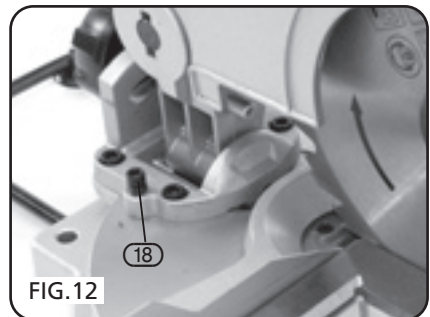
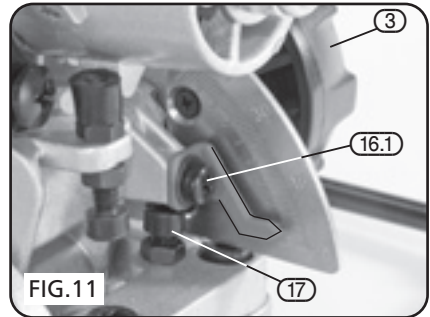
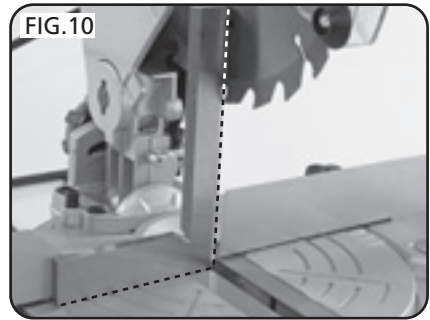

8. PREPARING THE MITRE SAW

8.11 CHECK THE FENCE TO BLADE ALIGNMENT - FIG. 13

NOTE: Remove the plug from the socket before carrying out adjustment, servicing or maintenance. Lower and lock the saw head. Set the mitre and bevel angles to zero and lock. Place a small engineers square flat against the fence and the blade making sure that the square contacts the flat side of the blade and not the teeth. The edge of the square should be parallel to the blade. If any adjustment is required loosen the hex. socket bolts at the rear of the fence, position the fence and against the square and retighten.

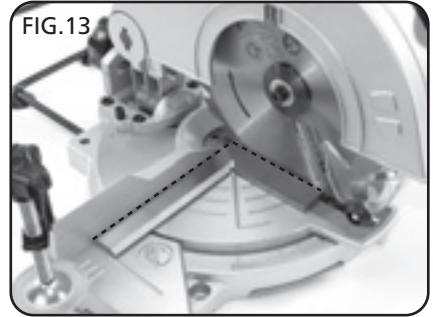

8.12 TABLE INSERT REPLACEMENT - FIG. 14

If the table insert becomes worn or damaged it must be replaced. Remove the screw (12.1) securing the table insert (12). Ensure the replacement table insert is fitted before attempting to operate the saw.

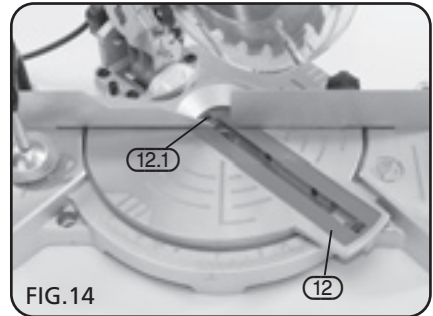

8. PREPARING THE MITRE SAW

8.13 BLADE REPLACEMENT - FIGS. 15 - 16

NOTE: Remove the plug from the socket before carrying out adjustment, servicing or maintenance. With the saw head in the raised position. Press the spindle lock button (19) and with the 6mm hex. key (20) loosen and remove the blade securing bolt (19.1) (clockwise to loosen as the bolt has a left-hand thread). Remove the clamping flange, taking note of the correct orientation for re-assembly. Rotate the clear lower blade guard so that the blade can be removed/refitted.

Ensure the specification of the replacement blade conforms with the machine (i.e. outer diameter, width, RPM and type, e.g. woodcutting etc). Before fitting the new blade wipe a drop of oil on the inner and outer flanges where the arbor locates.

Re-assemble the flanges and blade and secure.

NOTE: Install the blade with the direction of rotation arrow matching the direction of rotation arrow on the blade guard. The teeth face downward at the front of the saw.

Refit the lower blade guard and secure.

NOTE: This saw is not designed to cut metal or masonry.

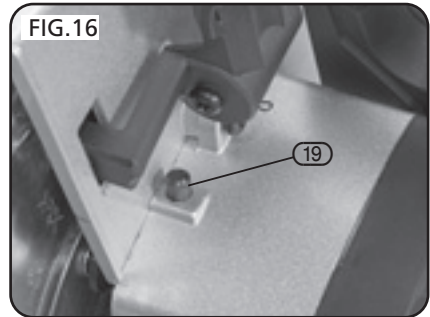
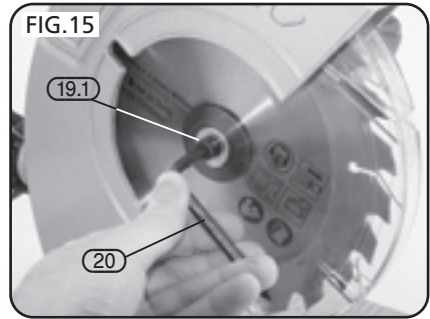

8.14 BASIC SAW OPERATIONS

WARNING: For your own safety, read and understand all safety instructions and operating procedures throughout the manual before using this machine.

8.15 BODY AND HAND POSITION

Proper positioning of your body and hands when operating the mitre saw will make cutting easier and safer. Never place hands near cutting area. Place hand at least 4" from path of blade. Hold workpiece firmly to the fence to prevent movement towards the blade. Keep hands in position until trigger has been released and the blade has completely stopped. Before making a cut, make a "dry run" with the power off so you can see the path of the blade.

WARNING: Do not try to cut short pieces, you cannot properly support the workpiece and hold down the workpiece by hand and keep your hand the required distance from the blade.

9. OPERATING THE MITRE SAW

9.1 MITRE CUT - FIG. 17

When a mitre cut is required, move the saw to the desired angle. Do not stand in front of the saw table. Move with the handle to the mitre angle to make the cut.

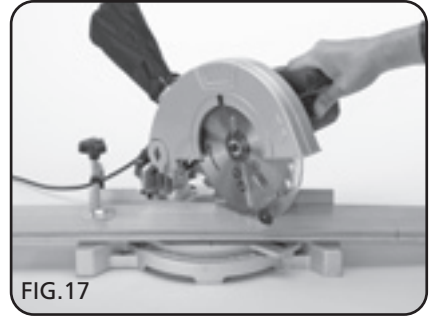

9.2 BEVEL CUT - FIG. 18

When a bevel cut is required, tilt the blade to the desired bevel angle. Stand to the left side of the handle to make the cut.



9.3 COMPOUND CUT - FIG. 19

When a compound cut is required, select the correct bevel and mitre position. Move with the handle to the mitre angle to make the cut.



9. OPERATING THE MITRE SAW

9.4 CUTTING CURVED OR WARPED MATERIAL - FIGS. 20 - 21

Before cutting a workpiece, check to make sure it is flat. If it is curved or warped, the workpiece must be positioned and cut as illustrated. Do not position workpiece incorrectly or try to cut the workpiece without the support of the fence. This will cause pinching of the workpiece on the blade. The workpiece could suddenly jump or move and your hand could hit the blade.

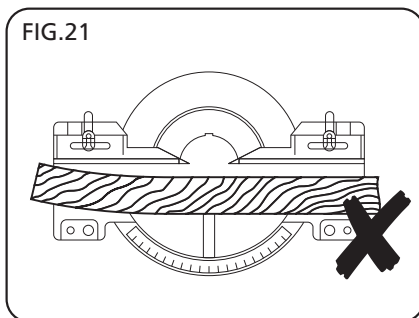
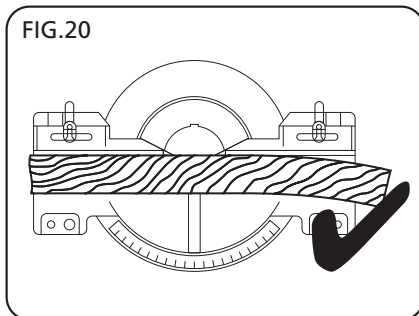

9. OPERATING THE MITRE SAW

9.5 WORKPIECE SUPPORT

Long pieces need extra supports. The supports should be placed along the workpiece so the workpiece does not sag and the hand holding the workpiece is positioned 4" or more from the blade path. The support should let the workpiece lay flat on the base and worktable during the cutting operation.

10. GLOSSARY OF TERMS FOR WOODWORKING

ARBOR/SPINDLE

The shaft on which a cutting tool is mounted.

BEVEL CUT

An angle cutting operation made through the face of the workpiece.

COMPOUND CUT

A simultaneous bevel and mitre cutting operation.

CROSS CUT

A cutting operation made across the width of the workpiece.

FREEHAND

Performing a cut without the use of fence (guide), hold down or use a proper device to prevent the workpiece from twisting during the cutting operation. Twisting the workpiece can cause it to be thrown.

GUM

A sticky, sap based residue from wood products.

HEEL

Misalignment of the blade.

KERF

The amount of material removed by the blade in a through cut or the slot produced by the blade in a non-through or partial cut.

MITRE CUT

An angle cutting operation made across the width of the workpiece.

RESIN

A stick, sap based substance that has dried and hardened.

REVOLUTIONS PER MINUTE (RPM)

The number of turns completed by a spinning object in one minute.

SAWBLADE PATH

The area of the workpiece or table top directly in line with either the travel of the blade or the part of the workpiece which will be, or has been, cut by the blade.

SET

The distance that the tip of the sawblade teeth are bent (or set) outward from the face of the blade.

WORKPIECE

The item on which the cutting operation is being performed. The surfaces of a workpiece are commonly referred to as faces, ends and edges.

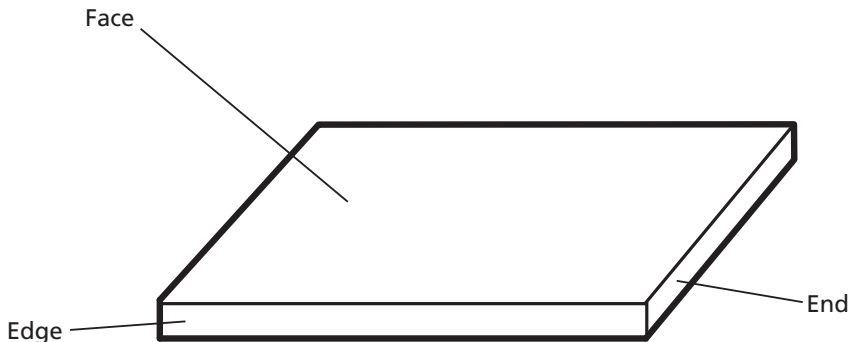

11. MAINTENANCE

Regular inspection and cleaning reduces the necessity for maintenance operations and will keep your tool in good working condition.

The motor must be correctly ventilated during tool operation. For this reason avoid blocking the air inlets. After use disconnect the tool from the power supply and vacuum the ventilation slots.

If the replacement of the supply cord is necessary, this has to be done by the manufacturer or his agent in order to avoid a safety hazard.

Always unplug the power cable before any maintenance check on this saw.

DANGER: Never put lubricants on the blade whilst it is spinning.

WARNING: To avoid injury from unexpected starting or electrical shock, unplug the power cable before working on the saw.

WARNING: For your safety, this saw is double insulated. To avoid electrical shock, fire or injury, use only parts identical to those identified in the parts list, reassemble exactly as original assembly to avoid electrical hazards.

BLADE GUARD

Do not use the saw without the lower guard. The lower blade guard is attached to the saw for protection. Should the lower guard become damaged, do not use the saw until the damaged guard has been replaced. Develop a regular check to make sure the lower guard is working properly. Clean the lower guard of any dust or build up with a damp cloth, with the power supply disconnected.

CAUTION: Do NOT use solvents on the guard. They could make the plastic 'cloudy' and brittle.

WARNING: When cleaning lower guard, unplug the saw from the outlet to avoid unexpected start-up or electrical shock.

SAWDUST

Periodically, sawdust will accumulate under the worktable, base and around the switch mechanisms. This could cause difficulty in the movement of the worktable when setting up a mitre cut or switching operations. Frequently vacuum up the sawdust.

RECOMMENDED ACCESSORIES

WARNING: To avoid injury from unsafe accessories, use only Draper accessories.

PROHIBITED ACCESSORIES

The use of any cutting tool except saw blades which meet the requirement under recommended accessories is prohibited. Do not use accessories such as shaper cutters or dado sets. Ferrous and non-ferrous metal cutting and the use of abrasive wheels are prohibited.

LUBRICATION

All the motor bearings in this tool are lubricated with a sufficient amount of high grade lubricant for the life of the unit under normal operating conditions, therefore, no further lubrication is required.

All the ball bearings are sealed and lubricated for life and will require no maintenance.

CLEANING

After use, wipe off chips and dust adhering to the tool with a cloth or the like. Keep the blade guard clean. Lubricate the sliding portions with machine oil to prevent rust.

To maintain product SAFETY and RELIABILITY, repairs and, any other maintenance or adjustment should be performed by your nearest authorised service centre.

12. TROUBLESHOOTING

NOTE: Remove the plug from the socket before carrying out adjustment, servicing or maintenance.

PROBLEM	POSSIBLE CAUSE	REMEDY
Motor does not start.	<ul style="list-style-type: none">• Fuse.• Brushes worn.• Unsure.	<ul style="list-style-type: none">• Replace time delay fuse or reset circuit breaker.• Have brushes replaced by an authorised service centre.• Contact an authorised service centre.
Poor cutting performance	<ul style="list-style-type: none">• Saw blade blunt• Saw blade incorrectly mounted• Incorrect saw blade selection	<ul style="list-style-type: none">• Stop machine immediately. Replace saw blade• Stop machine immediately. Remove & refit saw blade as per instructions• Seek advice on suitable saw blades
Saw vibrates	<ul style="list-style-type: none">• Saw blade distorted• Saw blade incorrectly mounted	<ul style="list-style-type: none">• Stop machine immediately & replace blade• Stop machine immediately Remove & refit saw blade as per instructions
Mitre position difficult to move	<ul style="list-style-type: none">• Build up of sawdust under table	<ul style="list-style-type: none">• Vacuum up sawdust

13. OPTIONAL ACCESSORIES

13.1 OPTIONAL ACCESSORIES

Stock No.	Part No.	Diameter	Bore	Teeth	Reducing Bushes Supplied	Description
09476	CSB210P	210mm	30mm	24T	16mm	Rip and Cross Cut
09477	CSB210P	210mm	30mm	40T	16mm	Cross Cut
09478	CSB210P	210mm	30mm	60T	16mm	Cross Cut

14. EXPLANATION OF SYMBOLS

14.1 EXPLANATION OF SYMBOLS



Warning!
Do not wear loose clothing.



Warning!
Read the instruction manual



Warning!
Wear suitable
eye/face protection.



Warning!
Keep hands away for blade.



Warning!
Wear dust mask.



Warning!
Wear ear defenders.



Double insulated.



Warning! Disable the machine
before attempting to maintain it.



WEEE
Do not dispose of Waste Electrical
& Electronic Equipment in with
domestic rubbish

15. DISPOSAL

15.1 DISPOSAL

- At the end of the machine's working life, or when it can no longer be repaired, ensure that it is disposed of according to national regulations.
- Contact your local authority for details of collection schemes in your area.

In all circumstances:

- Do not dispose of power tools with domestic waste.
- Do not incinerate.
- Do not abandon in the environment.
- Do not dispose of WEEE* as unsorted municipal waste.



* Waste Electrical & Electronic Equipment.

- **DRAPER TOOLS LIMITED,**
Hursley Road, Chandler's Ford,
Eastleigh, Hampshire. SO53 1YF. U.K.
- **Helpline:** (023) 8049 4344
- **Sales Desk:** (023) 8049 4333
- **General Enquiries:** (023) 8026 6355
- **Service/Warranty Repair Agent**
For aftersales servicing or warranty repairs, please
contact the Draper Tools Helpline for details of an
agent in your local area.

YOUR DRAPER STOCKIST

RDMC0816

