

**DRAPER**<sup>®</sup>

PETROL  
**CULTIVATOR/  
TILLER**

**32329**

**IMPORTANT:** PLEASE READ THESE INSTRUCTIONS CAREFULLY TO ENSURE THE SAFE AND EFFECTIVE USE OF THIS PRODUCT.



## **INSTRUCTIONS**

These instructions accompanying the product are the original instructions. This document is part of the product, keep it for the life of the product passing it on to any subsequent holder of the product. Read all these instructions before assembling, operating or maintaining this product.

This manual has been compiled by Draper Tools describing the purpose for which the product has been designed, and contains all the necessary information to ensure its correct and safe use. By following all the general safety instructions contained in this manual, it will ensure both product and operator safety, together with longer life of the product itself.

All photographs and drawings in this manual are supplied by Draper Tools to help illustrate the operation of the product.

Whilst every effort has been made to ensure the accuracy of information contained in this manual, the Draper Tools policy of continuous improvement determines the right to make modifications without prior warning.

# 1. TITLE PAGE

---

## 1.1 INTRODUCTION:

**USER MANUAL FOR: Petrol Cultivator/Tiller**

**Stock No: 32329**

**Part No: MT254**

## 1.2 REVISIONS:

---

**Date first published May 2017.**

---

**Date first revision June 2018.**

---

---

As our user manuals are continually updated, users should make sure that they use the very latest version.

**Downloads are available from:** <http://www.drapertools.com/manuals>

Draper Tools Limited  
Hursley Road  
Chandler's Ford  
Eastleigh  
Hampshire  
SO53 1YF  
UK

**Website:** [drapertools.com](http://drapertools.com)

**Product Helpline:** +44 (0) 23 8049 4344

**General Fax:** +44 (0) 23 8026 0784

## 1.3 UNDERSTANDING THIS MANUALS SAFETY CONTENT:

**WARNING!** – Information that draws attention to the risk of injury or death.

**CAUTION!** – Information that draws attention to the risk of damage to the product or surroundings.

## 1.4 COPYRIGHT © NOTICE:

Copyright © Draper Tools Limited.

Permission is granted to reproduce this publication for personal and educational use only. Commercial copying, redistribution, hiring or lending is prohibited.

No part of this publication may be stored in a retrieval system or transmitted in any other form or means without written permission from Draper Tools Limited.

In all cases this copyright notice must remain intact.

---

# 2. CONTENTS

---

## 1. TITLE PAGE

1.1 INTRODUCTION.....	2
1.2 REVISION HISTORY .....	2
1.3 UNDERSTANDING THIS MANUAL .....	2
1.4 COPYRIGHT NOTICE .....	2

## 2. CONTENTS

2.1 CONTENTS .....	3
--------------------	---

## 3. GUARANTEE

3.1 GUARANTEE .....	4
---------------------	---

## 4. INTRODUCTION

4.1 SCOPE.....	5
4.2 SPECIFICATION .....	5
4.3 HANDLING AND STORAGE.....	5

## 5. HEALTH AND SAFETY INFORMATION

5.1 SPECIFIC SAFETY INSTRUCTION FOR PETROL CULTIVATOR/TILLERS.....	6
<b>Service</b> .....	6
5.2 HEALTH AND SAFETY INFORMATION CONCERNING THE USE OF FUELS .....	7

## 6. TECHNICAL DESCRIPTION

6.1 IDENTIFICATION .....	8
--------------------------	---

## 7. UNPACKING AND CHECKING

7.1 PACKAGING .....	9
7.2 WHAT'S IN THE BOX.....	9

## 8. ASSEMBLING THE CULTIVATOR/TILLER

8.1 FITTING THE ROTAVATING BLADES .....	10
8.2 FITTING THE WHEEL BRACKET ASSEMBLY AND TRANSPORT WHEELS .....	11
8.3 FITTING THE HANDLE BARS.....	12
8.4 FITTING THE THROTTLE AND CABLE ASSEMBLY .....	12
8.5 GEARBOX .....	13
8.6 FUELLING.....	13

## 9. OPERATING INSTRUCTIONS

9.1 COLD STARTING THE ENGINE.....	14
9.2 WARM STARTING THE ENGINE .....	15
9.3 STOPPING THE ENGINE.....	15
9.4 USING THE CULTIVATOR/TILLER.....	16

## 10. MAINTENANCE AND TROUBLESHOOTING

10.1 CLEANING THE AIR FILTER.....	17
10.2 SPARK PLUG MAINTENANCE .....	18
10.3 STORAGE.....	18
10.4 STORING THE MACHINE FOR AN EXTENDED PERIOD OF TIME.....	18
10.5 TROUBLESHOOTING GUIDE.....	19
10.6 CLEANING AND MAINTENANCE OVERVIEW .....	19

## 11. EXPLANATION OF SYMBOLS

11.1 EXPLANATION OF SYMBOLS .....	20
-----------------------------------	----

## 12. DISPOSAL

12.1 DISPOSAL .....	21
---------------------	----

**DECLARATION OF CONFORMITY** ..... ENCLOSED

## 3. GUARANTEE

---

### 3.1 GUARANTEE

Draper tools have been carefully tested and inspected before shipment and are guaranteed to be free from defective materials and workmanship.

Should the tool develop a fault, please return the complete tool to your nearest distributor or contact:

**Draper Tools Limited, Chandler's Ford, Eastleigh, Hampshire, SO53 1YF. England.**

**Telephone Sales Desk: (023) 8049 4333** or:

**Product Helpline (023) 8049 4344.**

A proof of purchase must be provided with the tool.

If upon inspection it is found that the fault occurring is due to defective materials or workmanship, repairs will be carried out free of charge. This guarantee period covering parts/labour is 12 months from the date of purchase except where tools are hired out when the guarantee period is 90 days from the date of purchase. The guarantee is extended to 12 months for parts only. This guarantee does not apply to normal wear and tear, nor does it cover any damage caused by misuse, careless or unsafe handling, alterations, accidents, or repairs attempted or made by any personnel other than the authorised Draper warranty repair agent.

Note: If the tool is found not to be within the terms of warranty, repairs and carriage charges will be quoted and made accordingly.

This guarantee applies in lieu of any other guarantee expressed or implied and variations of its terms are not authorised.

Your Draper guarantee is not effective unless you can produce upon request a dated receipt or invoice to verify your proof of purchase within the guarantee period.

Please note that this guarantee is an additional benefit and does not affect your statutory rights.

**Draper Tools Limited.**



## 4. INTRODUCTION

---

### 4.1 SCOPE

This 2-stroke petrol cultivator/tiller is designed to prepare the ground for the planting of flowers and vegetables. Any other application is considered mis-use.

### 4.2 SPECIFICATION

Stock No: .....	32329
Part No: .....	MT254
Engine displacement .....	42.7cc
Maximum engine performance .....	1200W
Engine idle speed (no load).....	3,000min <sup>-1</sup>
Fuel tank capacity .....	1.2L
Fuel mixture.....	25:1 <sup>††</sup>
Tilling width .....	320mm
Tilling depth (max.) .....	150mm
Tines.....	4 teeth/230mm Ø
Sound pressure level .....	72.98dB(A)
Sound power level .....	93dB(A)
Single value noise level (LWA) <sup>†</sup> .....	93dB(A)
Weight (machine only).....	15.5kg

<sup>†</sup>A-weighted sound pressure level in accordance to 2000/14/EC.

<sup>††</sup>Use semi-synthetic 2 stroke oil.

### 4.3 HANDLING AND STORAGE

This machine is not a toy and must be respected. The environment will have a negative result on its operation if you are not careful. If the air is damp, components will rust. If the machine is unprotected from dust and debris; components will become clogged: And if not cleaned and maintained correctly or regularly the machine will not perform at its best.

## 5. HEALTH AND SAFETY INFORMATION

---

### 5.1 SPECIFIC SAFETY INSTRUCTIONS FOR PETROL CULTIVATOR/TILLERS

- To operate this device safely, the user must have read and understood these instructions for use before using the device for the first time.
- Observe all safety instructions. Failure to do so may cause harm to you and others.
- Children should be kept at a distance from the device.
- All parts of the device must be properly installed to ensure its proper operation.
- Young adults under 16 as well as users who are not sufficiently familiar with its operation may not operate this device.
- The device may not be used unless it is undamaged and functions properly. If the device or parts of it have become defective, have it repaired by an authorised Draper technician.
- The environment must be free of easily flammable materials and from those which are explosion hazards.
- Work only under good conditions of light and visibility. Do not use on frozen ground.
- The user must wear tightly fitting clothing. Avoid loose clothing. Wear robust footwear.
- The device must not be operated without safety equipment being in place.
- Beware of rotating implements – maintain a safe distance.
- Beware of implements which run on after the device has been switched off. Wait until these implements have come to a stop before working on them.
- Danger of toxicity caused by exhaust fumes. Starting the motor and using the device inside closed rooms is prohibited.
- Never leave the device unsupervised whilst its motor is running.
- Check the fuel system regularly for leaks or defective parts.
- Always switch off the motor when transporting or filling the device.
- Carefully clean away spilt fuel immediately.
- Retrofitting or making any unauthorised changes to the device as well as the use of unapproved parts are prohibited.
- Always obey the current national and international safety, health and working regulations.
- Always work with care and stay alert: it is irresponsible to use the device under conditions of tiredness, sickness, consumption of alcohol and the influence of drugs.

#### Service

Have your tool serviced by a qualified repair person using only identical replacement parts. This will ensure that the safety of the power tool is maintained.

- Maintenance and troubleshooting must be limited to the procedures described in these instructions for use. All other types of servicing must be conducted by an authorised Draper service technician.
- Use only original replacement parts. Only these parts are guaranteed to be designed and suitable for use with this device. Using other spare parts will void your claims under warranty and may cause danger to yourself and your surroundings.

## 5. HEALTH AND SAFETY INFORMATION

---

### 5.2 HEALTH AND SAFETY INFORMATION CONCERNING THE USE OF FUELS

Fuels are inflammable and explosive. Reduce the risk of explosion and fire by:

- Turning off and cooling the motor down before filling the tank with fuel.
- Refraining from smoking and starting open fires when handling fuels.
- Storing and mixing fuels in approved and correspondingly labelled canisters.
- Storing fuels in closed containers. Keeping in mind that fuels may evaporate at room temperature and collect on the floor of closed rooms (risk of explosion).
- Start the device at least nine metres away from any stored fuels or flammable liquids.

Fuels are toxic, they contain substances that have an immediate toxic effect and may cause permanent damage to your health. Take all precautionary measures to prevent your body from absorbing any of these substances:

- Tank and siphon fuels only outdoors or in well-ventilated rooms.
- Do not inhale fuel fumes.
- Avoid contact with eyes and skin.
- Wear gloves when transferring fuel.
- When fuel has come into contact with your clothes, change them immediately. Clean your clothes before putting them back on.
- Store fuels out of the reach of children.

When handled inappropriately, fuels may cause damage to the environment:

- Transfer fuel carefully. Fuel must never trickle into the ground or the sewage system.
- Dispose of any remaining fuel in an appropriate manner. Never dispose of fuel with regular household waste.
- Fuels may be stored only for a limited time. Purchase only such quantities that can be used up within a few months.

## 6. TECHNICAL DESCRIPTION

### 6.1 IDENTIFICATION

- ① Start/stop.
- ② Throttle.
- ③ Pull starter
- ④ Exhaust.
- ⑤ Fuel tank.
- ⑥ Fuel filler cap.
- ⑦ Rotavating blades x 4.
- ⑧ Transport wheel x 2.
- ⑨ Air filter cover.
- ⑩ Ignition cable plug.
- ⑪ Steering handle.
- ⑫ Guard.
- ⑬ Transport wheel axle fittings/adjusters



# 7. UNPACKING AND CHECKING

## 7.1 PACKAGING

Carefully remove the machine from the packaging and examine it for any sign of damage that may have happened during shipping. Lay the contents out and check them against the parts shown below. If any part is damaged or missing; please contact the Draper Helpline (the telephone number appears on the Title page) and do not attempt to use the machine.

The packaging material should be retained at least during the guarantee period: in case the machine needs to be returned for repair.

**Warning!** Some of the packaging materials used may be harmful to children. Do not leave any of these materials in the reach of children.

If any of the packaging is to be thrown away, make sure they are disposed of correctly; according to local regulations.

## 7.2 WHAT'S IN THE BOX?

As well as the cultivator/tiller, there are several parts not fitted or attached to it.

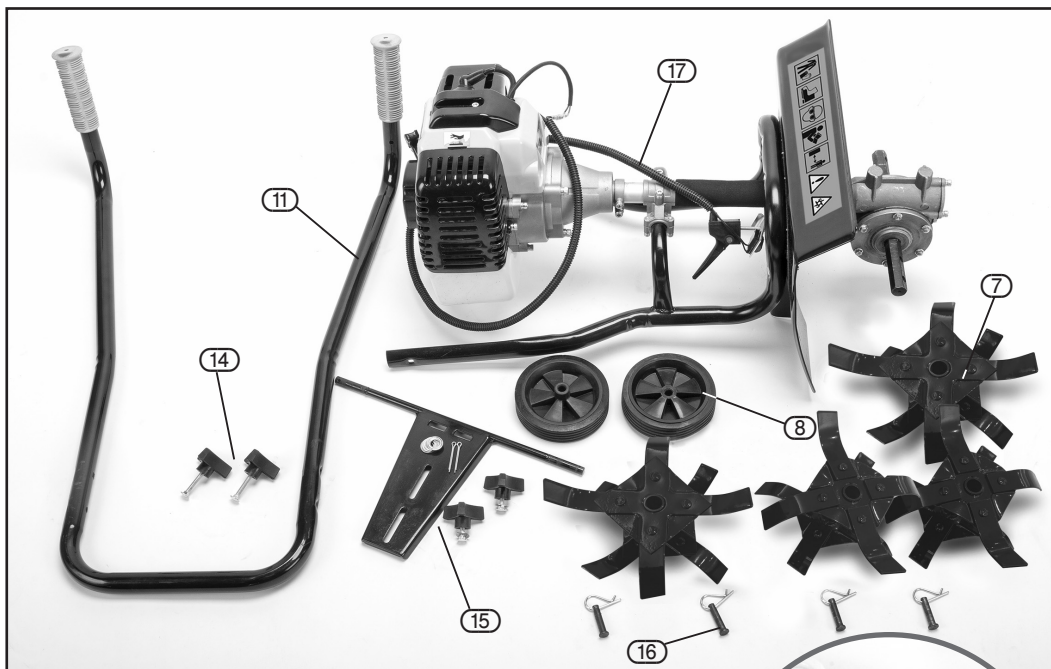

- (7) Rotavating blades × 4.
- (8) Transport wheel × 2.
- (11) Steering handle section.
- (14) Handle section fittings.
- (15) Transport wheel axle and fittings.
- (16) Blade fittings × 4.
- (17) Throttle cable/assembly.
- (18) Fuel mixing bottle.

- (19) Box spanner.
- (20) Combination spanner.
- (21) Small hex key.
- (22) Large hex key.
- (23) Screwdriver.

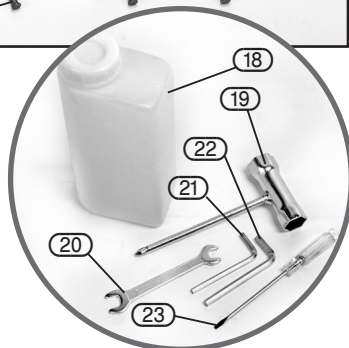

## 8. ASSEMBLING THE CULTIVATOR/TILLER

### 8.1 FITTING THE ROTAVATING BLADES

#### – FIGS. 1 – 4

**Note:** Some aspects of assembling this machine may require the need for two people.

- 1** The rotavating blades (7) are stamped **L** or **R** to identify their position on each side of the gearbox when facing the front of the machine.
  - Place the blades onto the axle (7.2) with the hubs (7.1) of blades facing each other.
  - Ensure that each of the blades and tines follow a rotationally 'staggered' pattern, in comparison to each other.
- 2** Insert a clevis pin (16.1) through the holes in each of the blades and pass it through the hole in the axle.
- 3** Lock the blades to the shaft by inserting a pin clip (16.3) through the hole in the end of the pin.

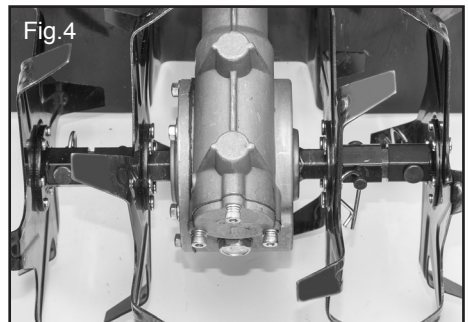
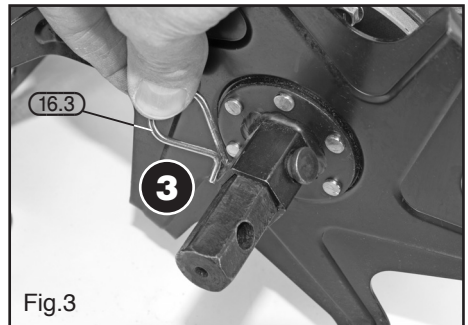
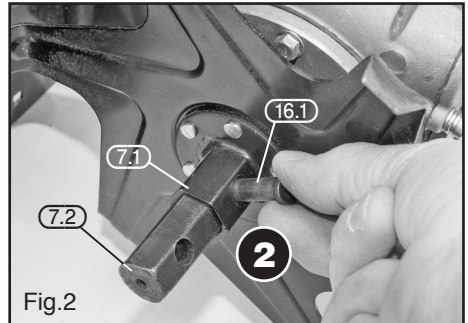
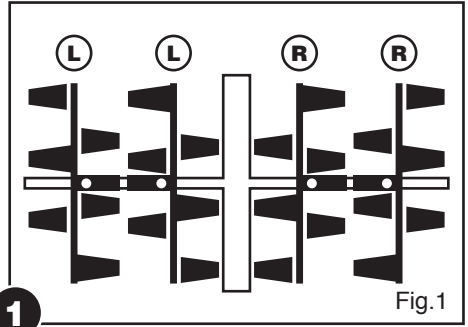

## 8. ASSEMBLING THE CULTIVATOR/TILLER

### 8.2 FITTING THE WHEEL BRACKET ASSEMBLY AND TRANSPORT WHEELS – FIGS. 5 – 8

- 1** Place the wheel bracket assembly (13) on the underside of the tine guard (12).
- 2** Make sure the square shoulder of the fixing bolts (13.1) are pushed through the slotted holes in the wheel bracket.
  - Place a washer (13.2) over the threaded end of the bolt.
  - Screw a plastic handle/adjuster (13.3) onto the bolt, taking care not to overtighten.
- 3** Working from either end of the wheel axle (13), place a washer (13.2) over the end of the wheel axle.
  - Place a wheel (8) onto the axle.
- 4** Thread a second washer over the end of the axle.
  - Fit a split pin (13.4) through the hole at the end of the wheel axle
- 5** Using a pair of pliers, bend the ends of the split pin to secure the wheel in place.
  - Repeat the above steps for the second wheel.

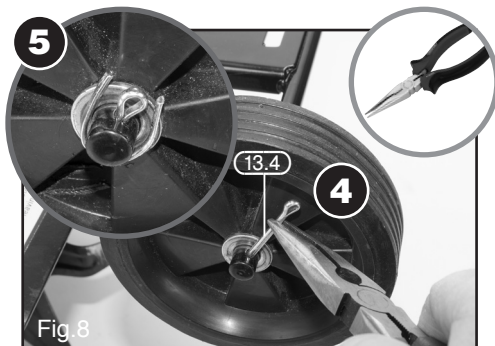
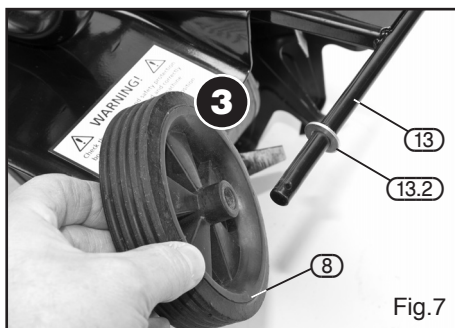
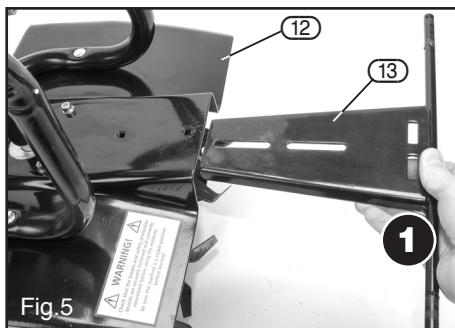



## 8. ASSEMBLING THE CULTIVATOR/TILLER

### 8.3 FITTING THE HANDLE BARS – FIGS. 9 – 10

- 1 Slide the steering handle bars section (11) into the supporting struts of the engine section (11.1).
- 2 Secure together using the 2 handle bar fixing bolts (14).

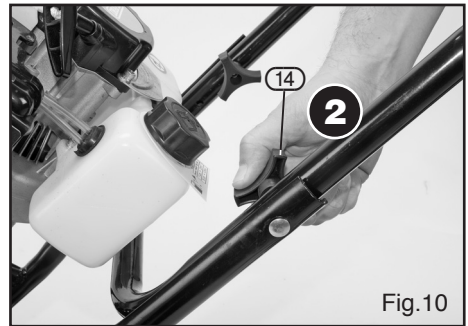
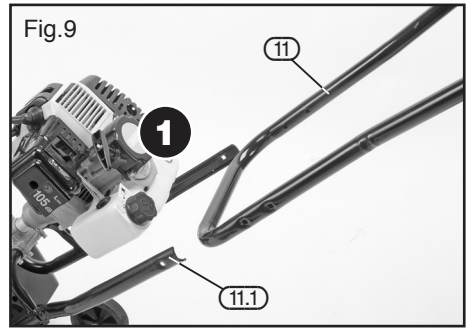

### 8.4 FITTING THE THROTTLE AND CABLE ASSEMBLY – FIGS. 11 – 12

- 1 Position the switch unit (1) of the throttle cable/trigger assembly onto the handle bars until the holes of both align.
- 2 When aligned, secure to the handle bars with the hex bolts using the hex key (22) supplied.
- 3 Secure the throttle cable (17) to the handlebars using electrical cable ties.

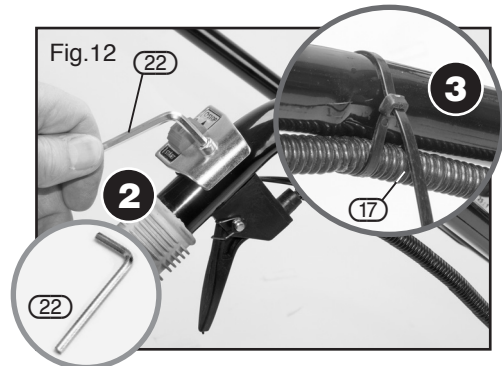
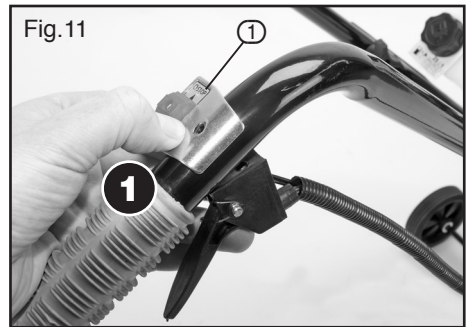



## 8. ASSEMBLING THE CULTIVATOR/TILLER

### 8.5 GEARBOX – FIG. 13

The gearbox of this product has been pre filled with grease and should not require any maintenance during the life of this machine. However the grease level can be checked by removing the screw indicated in Fig. 13.

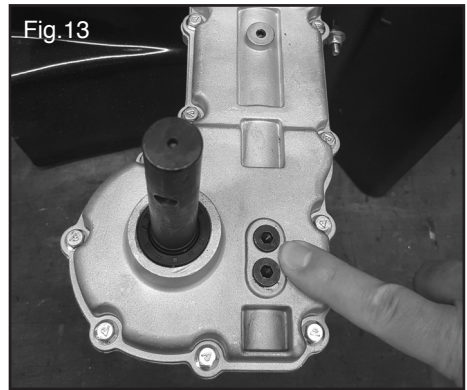

### 8.6 FUELLING – FIGS. 14 – 15

**Warning!** This cultivator/tiller is supplied without fuel. Before operating, it must be filled with fuel.

This type of engine requires a mixture of fuel and oil to perform and function. Failure to use the correct oil, fuel or mixture ratio will cause permanent damage to the engine. Only use fresh, clean, good quality unleaded fuel mixed with a high quality 2 stroke oil. **Do not use any other types of oil e.g. engine oil as this will cause damage to the engine.**

For synthetic oil or semi-synthetic a mix ratio of 25:1 must be used. To mix a ratio of 25:1:

- 1 Add 40ml of 2 stroke oil into 1 litre of unleaded fuel.

**Attention:** Always handle fuel with caution.

- 2 Pour the fuel/oil mixture into a specifically designed mixing receptacle before replacing the cap and shaking gently.
- 3 Remove the fuel tank cap (6) by turning it anti-clockwise. To prevent identification problems or accidents the fuel tank cap is stamped with the symbol .
- 4 With the aid of a funnel pour the fuel/oil mixture into the fuel tank before replacing the cap firmly. Avoid spillage and do not over fill.

**Note:** Always mix and refuel in a well ventilated area away from sources of ignition.

**Note:** Store fuel for short periods only and avoid mixing more than is required. Store in a container specifically designed for petrochemical applications away from heat and direct sun light.

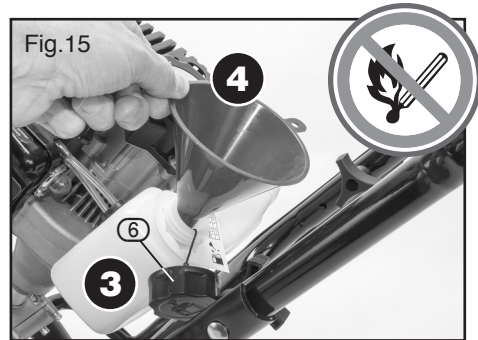
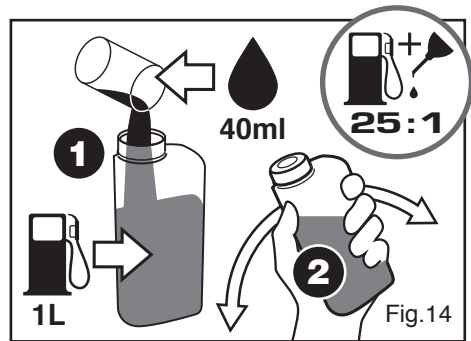

## 9. OPERATING INSTRUCTIONS

### 9.1 COLD STARTING THE ENGINE – FIGS. 16 – 19

1 Slide the START/STOP switch ① to the START position.

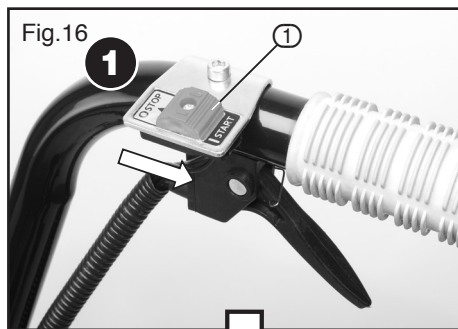

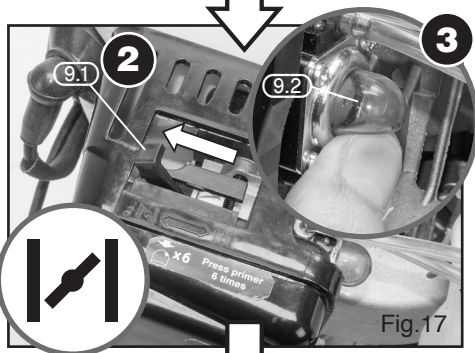

2 Slide the choke lever (9.1) towards the  off (closed) position.

3 Pump the primer (9.2) 6 to 8 times until you see fuel flow through the transparent hose from the fuel tank to the carburettor.



4 Put your foot on the frame to help steady the machine.

5 Pull the starter cord (3) until the engine fires – it should take only a few pulls.

6 Allow the engine to run for 5 seconds and then move the choke lever halfway back towards the  on (open) position. Allow the engine to run for another 5 seconds to warm up, then move the choke lever to the fully  open (on) position.

**Note:** Do not use the full length of the recoil starter cord (3) as this can cause breakage or premature failure. Do not release the starter cord to recoil on its own. Damage will occur to the mechanism.

**Note:** If there is a strong smell of fuel this indicates that the engine may be flooded. Wait a few minutes before attempting to restart the machine as if the engine were warm i.e. no choke.

7 Once the motor has started, allow the motor to warm up for a few minutes before commencing tilling.

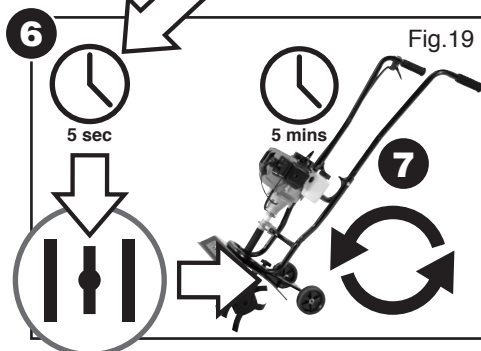

## 9. OPERATING INSTRUCTIONS

### 9.2 WARM STARTING THE ENGINE – FIGS. 20 – 21

- 1 Slide the START/STOP switch ① to the START position.

**Note:** When starting a warm engine, there is no need to prime the engine and the choke lever should be left in the  open (on) position.

- 2 Put your foot on the frame to help steady the machine.
  - 3 Pull the starter cord ③ until the engine fires – it should take only a few pulls.
- If the engine does not start, refer to the steps highlighted in the previous section: 9.1 Cold Starting the Engine.

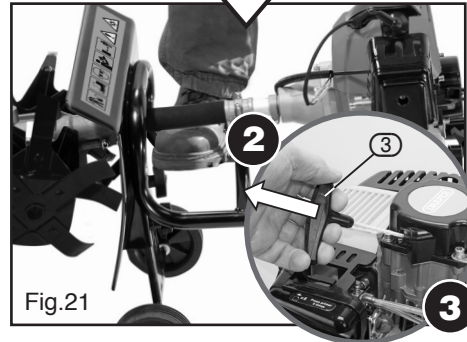
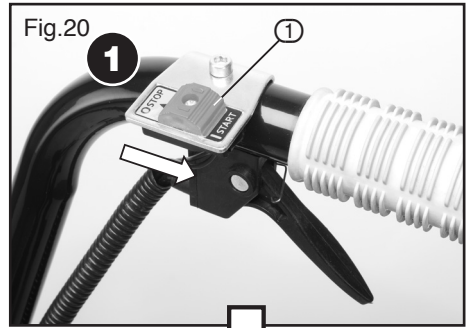

### 9.3 STOPPING THE ENGINE – FIG. 22

- 1 Slide the START/STOP switch ① to the STOP position.

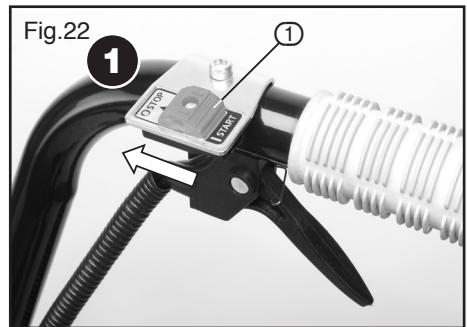

## 9. OPERATING INSTRUCTIONS



### 9.4 USING THE CULTIVATOR/TILLER – FIGS. 23 – 25

- 1 With the engine running tilt back the machine so that the blades are raised from the ground.
- 2 Gradually increase the engine speed by pulling up the throttle control lever (17.1).

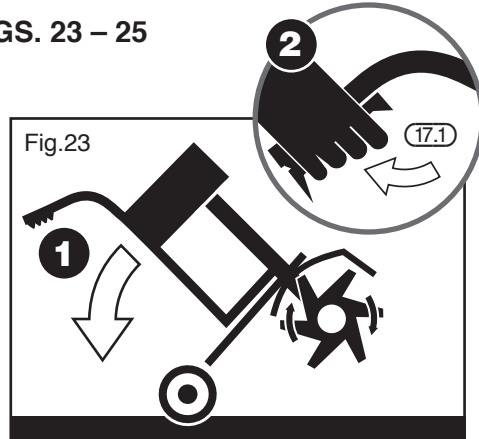

- 3 Holding the handlebars firmly, lower the tiller onto the soil. As the tines rotate, pull back on the handles so that the tines can penetrate the soil. Once the ground has been broken, continue at a moderate pace until you are familiar with the controls and the handling of the tiller.

- Pull the tiller backwards to improve the depth of the cultivation and reduce your effort.



If the tines are digging too deep or not enough, adjust following the below guidelines:

Tine adjustment will vary depending on the type of soil being cultivated and how it will be used.

- 4 Stop the engine and loosen the knobs (12.1) on the tine guard (12).
  - 5 Slide the wheel bracket assembly (15) down for shallower digging.
  - 6 Slide the wheel bracket assembly (15) up for deeper digging.
- Tighten the wing nuts again, making sure that the carriage bolts are properly seated through the bracket.

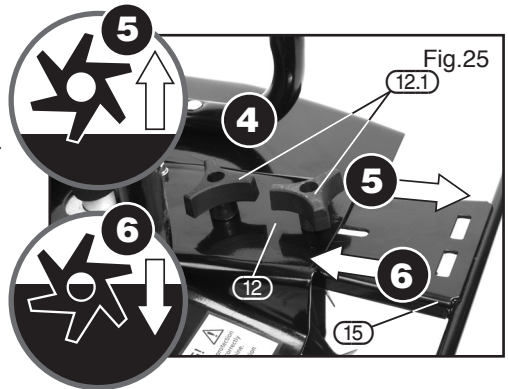

To transport, slide the wheel bracket assembly all the way down, tilt the unit back so that the tines clear the ground and push to the next location using the transport wheels.

# 10. MAINTENANCE AND TROUBLESHOOTING

Regular maintenance tasks must be carried out at specific intervals to retain the engine's performance.

## 10.1 CLEANING THE AIR FILTER – FIGS. 26 – 29

A dirty, clogged air filter will restrict the air flow in to the engine and will cause rough running. It will increase fuel consumption and may result in starting problems.

**Attention:** Stop the engine before removing the air filter assembly.

- 1 Set the choke lever (9.1) to the closed position to prevent any debris entering the carburettor inlet.
  - 2 Using the supplied hex key (22) to remove the air filter cover (9).
  - 3 Lift air filter cover (9) away free
  - 4 Pull back the air filter element cover (9.2) to expose the foam element.
  - 5 Remove the foam air filter element (9.3).
  - 6 Wash the element in warm soapy water to clean it. Do not use solvents to clean it.
- Allow the filter to dry 100% before refitting it on to the engine.
- Refit element cover (9.2).
  - Refit air filter cover (9).
  - Use hex. key (22) to re-tighten in place.

**Note:** Replace the filter element if it appears worn or damaged.

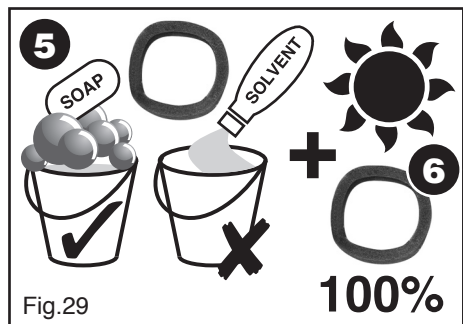
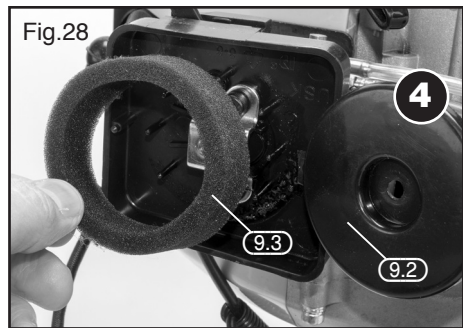
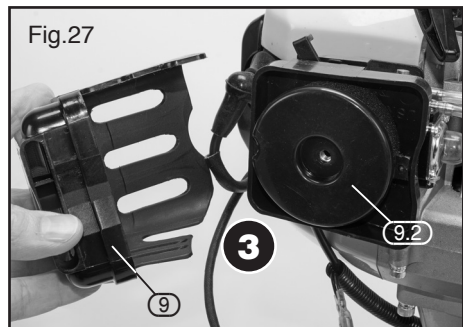

# 10. MAINTENANCE AND TROUBLESHOOTING

## 10.2 SPARK PLUG MAINTENANCE – FIGS. 30 – 31

Over time the spark plug can become contaminated. This can be due to adverse running conditions such as, working with part throttle for a prolonged period or a fuel mix containing too much oil. This contamination can build up causing the engine to run roughly, reduce the fuel consumption or create starting problems.

- 1** Without using any tools so as to avoid damaging the H.T. lead, remove the lead (10) from the back of the spark plug.
- 2** Using the box spanner supplied (19), turn the spark plug (10.1) anticlockwise to remove it.
- 3** Clean the spark plug and check the electrode gap. Maintain a gap of 0.6 to 0.7mm.

**Note:** When re-fitting/replacing the spark plug, screw in hand tight, then use the box spanner to tighten – **no more than a quarter turn** – as overtightening could lead to damage of the screw thread.

**Attention:** The spark plug should be replaced every 50 hours of machine use or annually during a service. When replacing, an L7T coded spark plug must be used.

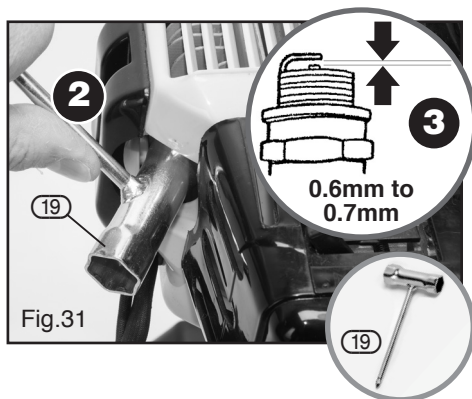
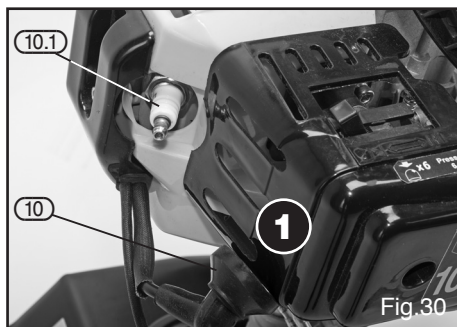

## 10.3 STORAGE

- Let the engine cool down completely before storing away.
- Store the machine in a place which is dry and well ventilated.

## 10.4 STORING THE MACHINE FOR AN EXTENDED PERIOD OF TIME (3 MONTHS OR LONGER)

Before an extended period of disuse, you must remove the fuel from the machine.

- Drain the fuel tank, then start the engine and let it run until it stops of its own accord.



# 10. MAINTENANCE AND TROUBLESHOOTING

## 10.5 TROUBLESHOOTING GUIDE

Fault	Possible cause	Remedy
Engine does not start.	<ol style="list-style-type: none"><li>1. No fuel in the tank.</li><li>2. The STOP/START switch is in the STOP position.</li><li>3. Ignition cable plug not firmly attached.</li><li>4. Ignition cable plug dirty.</li><li>5. Is there fuel inside the combustion chamber.</li><li>6. The spark plug is dirty.</li><li>7. The distance between the electrodes of the spark plug is too large.</li><li>8. Wrong fuel.</li><li>9. Spark plug defective.</li></ol>	<ol style="list-style-type: none"><li>1. Refuel tank.</li><li>2. Put the switch in the START position.</li><li>3. Push the plug on tightly.</li><li>4. Clean the plug.</li><li>5. Remove the spark plug, dry off the electrode and start at full throttle.</li><li>6. Clean the spark section.</li><li>7. Set the gap to 0.7 to 0.8mm.</li><li>8. Drain the tank and fill it with the correct fuel.</li><li>9. Replace the spark plug.</li></ol>
Machine runs but stutters.	<ol style="list-style-type: none"><li>1. Is the choke set to the off (closed) position.</li></ol>	<ol style="list-style-type: none"><li>1. Set the choke to the on (open) position.</li></ol>
The motor does not reach its maximum speed.	<ol style="list-style-type: none"><li>1. The air filter is dirty.</li><li>2. The spark plug is dirty.</li><li>3. The distance between the electrodes of the spark plug is too large.</li><li>4. Wrong fuel.</li></ol>	<ol style="list-style-type: none"><li>1. Clean the air filter.</li><li>2. Clean the spark plug.</li><li>3. Set the gap to 0.7 to 0.8mm.</li><li>4. Drain the tank and fill with the correct fuel.</li></ol>

**Important:** Please note, all repairs/servicing should be carried out by a qualified person.

## 10.6 CLEANING AND MAINTENANCE OVERVIEW

Prior to every start	
<ol style="list-style-type: none"><li>1. Cleaning the air filter.</li><li>2. Check the pull starter for damage to the starter .</li><li>3. Checking threaded connections for tightness.</li></ol>	<ol style="list-style-type: none"><li>1. – See section 10.1 page 17.</li><li>2. – Visual inspection.</li><li>3. – Visual inspection/testing.</li></ol>
Every 50 operating hours or every 6 months	
<ol style="list-style-type: none"><li>1. Cleaning/replacing the spark plug.</li></ol>	<ol style="list-style-type: none"><li>1. – See section 10.2 page 18.</li></ol>

# 11. EXPLANATION OF SYMBOLS

## 11.1 EXPLANATION OF SYMBOLS



Single value noise marking.  
(Maximum declared  
A-Weighted sound power level  
in decibels).



**Warning!**  
Hot surface.



**Warning!**  
Wear suitable protective clothing  
and suitable gloves.



Fuel/2-stroke oil mixture ratio.



**Warning!**  
Wear suitable foot protection.



Strictly no naked flames or  
smoking near the appliance.



**Warning!**  
Wear suitable eye protection.



Choke closed.



**Warning!**  
Wear suitable ear protection.



Choke open.



**Warning!**  
Read the instruction manual.



**Warning!**  
Keep out of the reach of children.



**Warning!**  
Keep bystanders away.



**Warning!**  
Risk of danger to wildlife.



## 12. DISPOSAL

---

### 12.1 DISPOSAL

- At the end of the machine's working life, or when it can no longer be repaired, ensure that it is disposed of according to national regulations.
- Contact your local authority for details of collection schemes in your area.

In all circumstances:

- Do not dispose of power tools with domestic waste.
- Do not incinerate.
- Do not abandon in the environment.
- When decommissioning (preparing the machine to be scrapped) drain any remaining fuel and oil for separate disposal.





## CONTACTS

- **DRAPER TOOLS LIMITED,**  
Hursley Road, Chandler's Ford,  
Eastleigh, Hampshire. SO53 1YF. U.K.
- **Helpline:** (023) 8049 4344
- **Sales Desk:** (023) 8049 4333
- **Internet:** [www.drapertools.com](http://www.drapertools.com)
- **E-mail:** [sales@drapertools.com](mailto:sales@drapertools.com)
- **Sales Fax:** (023) 8049 4209
- **General Enquiries:** (023) 8026 6355
- **Service/Warranty Repair Agent**  
For aftersales servicing or warranty repairs, please contact the Draper Tools Helpline for details of an agent in your local area.

YOUR DRAPER STOCKIST

KCCH0317

©Published by Draper Tools Limited.

No part of this publication may be reproduced, stored in a retrieval system or transmitted in any form or by any means, electronic, mechanical photocopying, recording or otherwise without prior permission in writing from Draper Tools Ltd.