

DRAPER®

®

INSTRUCTIONS FOR **350W 230V** **5 Speed Hobby Bench Drill**

Stock No.38255 Part No.D13/5DA

IMPORTANT: PLEASE READ THESE INSTRUCTIONS CAREFULLY TO ENSURE THE SAFE AND EFFECTIVE USE OF THIS PRODUCT.



CE

DRAPER®

GENERAL INFORMATION

These instructions accompanying the product are the original instructions. This document is part of the product, keep it for the life of the product passing it on to any subsequent holder of the product. Read all these instructions before assembling, operating or maintaining this product.

This manual has been compiled by Draper Tools describing the purpose for which the product has been designed, and contains all the necessary information to ensure its correct and safe use. By following all the general safety instructions contained in this manual, it will ensure both product and operator safety, together with longer life of the product itself.

All photographs and drawings in this manual are supplied by Draper Tools to help illustrate the operation of the product.

Whilst every effort has been made to ensure the accuracy of information contained in this manual, the Draper Tools policy of continuous improvement determines the right to make modifications without prior warning.

1. TITLE PAGE

1.1 INTRODUCTION:

USER MANUAL FOR:

350W 230V 5 SPEED HOBBY BENCH DRILL

Stock no. 38255

Part no. D13/5DA

1.2 REVISIONS:

Date first published MARCH 2014

As our user manuals are continually updated, users should make sure that they use the very latest version.

Downloads are available from: <http://www.drapertools.com/b2c/b2cmanuals.pgm>

DRAPER TOOLS LIMITED

HURSLEY ROAD

CHANDLER'S FORD

EASTLEIGH

HAMPSHIRE

SO53 1YF

UK

WEBSITE: www.drapertools.com

PRODUCT HELPLINE: +44 (0) 23 8049 4344

GENERAL FAX: +44 (0) 23 8026 0784

1.3 UNDERSTANDING THIS MANUALS SAFETY CONTENT:

WARNING! Information that draws attention to the risk of injury or death.

CAUTION! Information that draws attention to the risk of damage to the product or surroundings.

1.4 COPYRIGHT © NOTICE:

Copyright © Draper Tools Limited.

Permission is granted to reproduce this publication for personal & educational use only. Commercial copying, redistribution, hiring or lending is prohibited.

No part of this publication may be stored in a retrieval system or transmitted in any other form or means without written permission from Draper Tools Limited.

In all cases this copyright notice must remain intact.

2. CONTENTS

2.1 CONTENTS

	Page content	Page
1	TITLE PAGE	
	1.1 INTRODUCTION	2
	1.2 REVISION HISTORY.....	2
	1.3 UNDERSTANDING THIS MANUAL	2
	1.4 COPYRIGHT NOTICE.....	2
2	CONTENTS	
	2.1 CONTENTS	3
3	GUARANTEE	
	3.1 GUARANTEE	4
4	INTRODUCTION	
	4.1 SCOPE	5
	4.2 SPECIFICATION	5
	4.3 HANDLING & STORAGE	5
5	HEALTH & SAFETY INFORMATION	
	5.1 GENERAL SAFETY INSTRUCTIONS FOR POWER TOOL USE	6-8
	5.2 SPECIFIC SAFETY INSTRUCTIONS FOR DRILL PRESSES USE	8-9A
	5.3 CONNECTION TO THE POWER SUPPLY	9A
6	TECHNICAL DESCRIPTION	
	6.1 IDENTIFICATION	10B
	6.2 MAIN COMPONENT DESCRIPTIONS	10A
7	UNPACKING & CHECKING	
	7.1 PACKAGING.....	11
	7.2 WHAT'S IN THE BOX?	11
8	PREPARING THE BENCH DRILL	
	8.1 BASE TO COLUMN	12
	8.2 TABLE.....	12
	8.3 HEAD	12
	8.4 PLUNGE HANDLES.....	12
	8.5 CHUCK	13
	8.6 CHUCK GUARD.....	13
	8.7 BENCH MOUNTING	13
9	SETTING THE BENCH DRILL	
	9.1 SPINDLE SPEED ADJUSTMENT	14
	9.2 DRILL BIT INSTALLATION/REPLACEMENT	15
	9.3 NO-VOLT SWITCH	15
	9.4 WORK TABLE ADJUSTMENT.....	15
	9.5 GENERAL DRILLING	16
	9.6 DUST AND SWARF	16
10	TROUBLESHOOTING	17
11	MAINTENANCE	18
12	ACCESSORIES.....	19
13	DISPOSAL	
	13.1 DISPOSAL.....	20
14	EXPLANATION OF SYMBOLS	21
	DECLARATION OF CONFORMITY	ENCLOSED

3. GUARANTEE

3.1 GUARANTEE

Draper tools have been carefully tested and inspected before shipment and are guaranteed to be free from defective materials and workmanship.

Should the tool develop a fault, please return the complete tool to your nearest distributor or contact Draper Tools Limited, Chandler's Ford, Eastleigh, Hampshire, SO53 1YF. England. Telephone Sales Desk: (023) 8049 4333 or Product Helpline (023) 8049 4344.

A proof of purchase must be provided with the tool.

If upon inspection it is found that the fault occurring is due to defective materials or workmanship, repairs will be carried out free of charge. This guarantee period covering parts/labour is 12 months from the date of purchase except where tools are hired out when the guarantee period is ninety days from the date of purchase. The guarantee is extended to 24 months for parts only. This guarantee does not apply to normal wear and tear, nor does it cover any damage caused by misuse, careless or unsafe handling, alterations, accidents, or repairs attempted or made by any personnel other than the authorised Draper warranty repair agent.

Note: If the tool is found not to be within the terms of warranty, repairs and carriage charges will be quoted and made accordingly.

This guarantee applies in lieu of any other guarantee expressed or implied and variations of its terms are not authorised.

Your Draper guarantee is not effective unless you can produce upon request a dated receipt or invoice to verify your proof of purchase within the guarantee period.

Please note that this guarantee is an additional benefit and does not affect your statutory rights.

Draper Tools Limited.

4. INTRODUCTION

4.1 SCOPE

Five speed bench drill with a 13mm chuck.

Ideal suited for the DIY and hobby user.

Designed to drill into wood, plastics, ceramics and many metals (drill bits sold separately).

4.2 SPECIFICATION

Stock no	38255
Part no.	D13/5DA
Rated voltage	230V~50Hz
Rated input	350W
Speed settings	5
Revolutions per minute (no load)	580-2,650min ⁻¹
Chuck capacity	1.5-13mm
Spindle travel	50mm
Throat	104mm
Column Ø	46mm
Chuck to table	160mm
Chuck to base	240mm
Table tilt	±45°
Head rotation	360°
Table rotation	360°
Table dimensions	158x162mm
Base dimensions	200x314mm
Height	580mm
Sound pressure level	62dB(A)
Sound power level	75dB(A)
Weight (nett)	16.5kg

4.3 HANDLING & STORAGE

The environment will have a negative result on its operation if you are not careful. If the air is damp, components will rust. If the machine is unprotected from dust and debris; components will become clogged: And if not cleaned and maintained correctly or regularly the machine will not perform at its best.

5. HEALTH & SAFETY INFORMATION

5.1 GENERAL SAFETY INSTRUCTIONS FOR POWER TOOL USE

When using any type of power tool there are steps that should be taken to make sure that you, as the user, remain safe.

Common sense and a respect for the tool will help reduce the risk of injury.

Read the instruction manual fully. Do not attempt any operation until you have read and understood this manual.

Most important you must know how to safely start and stop this machine, especially in an emergency.

Keep the work area tidy and clean. Attempting to clear clutter from around the machine during use will reduce your concentration. Mess on the floor creates a trip hazard. Any liquid spilt on the floor could result in you slipping.

Find a suitable location. If the machine is bench mounted; the location should provide good natural light or artificial lighting as a replacement. Avoid damp and dust locations as it will have a negative effect on the machine's performance.

If the machine is portable; do not expose the tool to rain. In all cases do not operate power tools near any flammable materials.

Beware of electric shock. Avoid contact with earthed surfaces; because they can conduct electricity if there is an electrical fault with the power tool. Always protect the power cable and route it away from danger.

Keep bystanders away. Children, onlookers and passers by must be restricted from entering the work area for their own protection. The barrier must extend a suitable distance from the tool user.

Unplug and house all power tools that are not in use. A power tool should never be left unattended while connected to the power supply. They must be housed in a suitable location, away locked up and from children.

Do not overload or misuse the tool. All tools are designed for a purpose and are limited to what they are capable of doing. Do not attempt to use a power tool (or adapt it in any way) for an application it is not designed for. Select a tool appropriate for the size of the job. Overloading a tool will result in tool failure and user injury: This covers the use of accessories.

Dress properly. Loose clothing, long hair and jewellery are all dangerous because they can become entangled in moving machinery: This can also result in parts of body being pulled into the machine.

Clothing should be close fitted, with any long hair tied back, jewellery and neck ties removed. Footwear must be fully enclosed and have a nonslip sole.

5. HEALTH & SAFETY INFORMATION

Wear personal protective equipment (PPE). Dust, noise, vibration and swarf can all be dangerous if not suitably protected against. If the work involving the power tool creates dust or fumes; wear a dust mask. Vibration to the hand, caused by operating some tools for longer periods must be protected against. Wear vibration reducing gloves and allow long breaks between uses. Protect against dust and swarf by wearing approved safety goggles or a face shield. These are some of the more common hazards and preventions; however, always find out what hazards are associated with the machine/work process and wear the most suitable protective equipment available.

Do not breathe contaminated air. If the work creates dust or fumes; connect the machine (if possible) to an extraction system either locally or remotely. Working outdoors can also help if possible.

Move the machine as instructed. If the machine is hand held, do not carry it by the power supply cable. If the product is heavy; employ a second or third person to help move it safely or use a mechanical device. Always refer to the instructions for the correct method.

Do not overreach. Extending your body too far can result in a loss of balance and you falling. This could be from a height or onto a machine and will result in injury.

Maintain your tools correctly. A well maintained tool will do the job safely. Replace any damaged or missing parts immediately with original parts from the manufacturer. As applicable; keep blades sharp; moving parts clean, oiled or greased; handles clean; and emergency devices working.

Wait for the machine to stop. Unless the machine is fitted with a safety brake; some parts may continue to move due to momentum. Wait for all parts to stop; then unplug it from the power supply before making any adjustments, carrying out maintenance operations or just finishing using the tool.

Remove and check setting tools. Some machinery requires the use of additional tools or keys to set, load or adjust the power tool. Before starting the power tool always check to make certain they have been removed and are safely away from the machine.

Prevent unintentional starting. Before plugging any machine in to the power supply, make sure the switch is in the OFF position. If the machine is portable; do not hold the machine near the switch and take care when putting the machine down; that nothing can operate the switch.

Carefully select an extension lead. Some machines are not suitable for use with extension leads. If the tool is designed for use outdoors; use an extension lead also suitable for that environment. When using an extended lead, select one capable of handling the current (amps) drawn by the machine in use. Fully extend the lead regardless of the distance between the power supply and the tool. Excess current (amps) and a coiled extension lead will both cause the cable to heat up and can result in fire.

Concentrate and stay alert. Distractions are likely to cause an accident. Never operate a power tool if you are under the influence of drugs (prescription or otherwise), including alcohol or if you are feeling tired. Being disorientated will result in an accident.

5. HEALTH & SAFETY INFORMATION

Have this tool repaired by a qualified person. This tool is designed to conform to the relevant international and local standards and as such should be maintained and repaired by someone qualified; using only original parts supplied by the manufacturer: This will ensure the tool remains safe to use.

5.2 SPECIFIC SAFETY INSTRUCTION FOR DRILL PRESSES USE

ADDITIONAL SAFETY INSTRUCTIONS FOR BENCH DRILLS

MECHANICAL HAZARDS:

1. Crushing

When setting/changing a tool or maintaining the machine avoid crushing injuries sustained between fixed and moving elements of the machine.

2. Cutting or Severing

At all times the workpiece shall be clamped as manual support will lead to injury.

3. Entanglement

Switch off the machine for maintenance, workpiece loading/unloading, swarf/chip removal, cutting/lubrication fluid application as contact with rotating spindle or tool will cause entanglement and possibly lead to injury and entrapment.

4. Impact

Ensure the workpiece is securely clamped at all times to avoid sudden movement (rotation) or ejection causing injury. Ensure any special tools associated with tool exchange, i.e. chuck key are removed prior to attempting to start the machine.

5. Stabbing, Cutting or Puncture Wounds

Take care when handling the tools and avoid contact with swarf and burrs created during drilling as they are extremely sharp.

ELECTRICAL HAZARDS:

1. Contact with Live parts

During commissioning, maintenance and trouble shooting operations do not remove, open or expose any electrical, terminal and control boxes due to the danger of electrocution. If the main cable is damaged, unplug the machine immediately and have the cable replaced before continuing.

AUDIBLE HAZARDS:

1. Hearing Loss

Wear ear defenders during operation to avoid damage to hearing, however ensure this does not interfere with speech communications or audible warnings.

MATERIAL HAZARDS:

1. Contact and Inhalation

Wear personal protective equipment to avoid contact from harmful fluids, gases or dust thrown or created during the drilling process.

2. Fire or Explosion

Do not drill or drill in the vicinity of flammable or combustible materials.

5. HEALTH & SAFETY INFORMATION

LOCATION:

1. Posture

Ensure when mounting the machine that the chosen location does not lead to unhealthy posture or repetitive strain during normal operation.

2. Lighting

Adequate lighting must be provided to ensure no operations are light impaired possibly leading to injury.

3. Reach

Do not reach over or around the machine at any time.

UNEXPECTED START-UP:

1. Remove the plug

Remove the plug from the socket before carrying out adjustment, servicing or maintenance.

ERRORS OF FITTING:

1. Tools

Ensure a suitable tool for the job in hand is securely and correctly fitted prior to starting the machine.

Guards shall be fitted and in place at all times.

STABILITY:

1. Toppling

The drill shall be securely bolted down to a suitable and level surface to prevent the machine from overturning leading to injury.

2. Slipping

Ensure the area is clean of any residue cutting/lubrication fluid and other materials which may lead to a slip, trip or other such hazard.

5.3 CONNECTION TO THE POWER SUPPLY

Make sure the power supply information on the machine's rating plate are compatible with the power supply you intend to connect it to.

The Drill comes supplied with a UK standard 3 pin plug fitted. It is designed for connection to a domestic power supply rated at 230V AC.

Because it is constructed mostly of metal parts, it is a Class 1 machine; meaning, it must have an earth connection in the power supply. This is to prevent electrocution in the event of a failure.

Apart from replacing the fuse in the plug, no other electrical work is recommended on this drill.

6. TECHNICAL DESCRIPTION

6.1 IDENTIFICATION

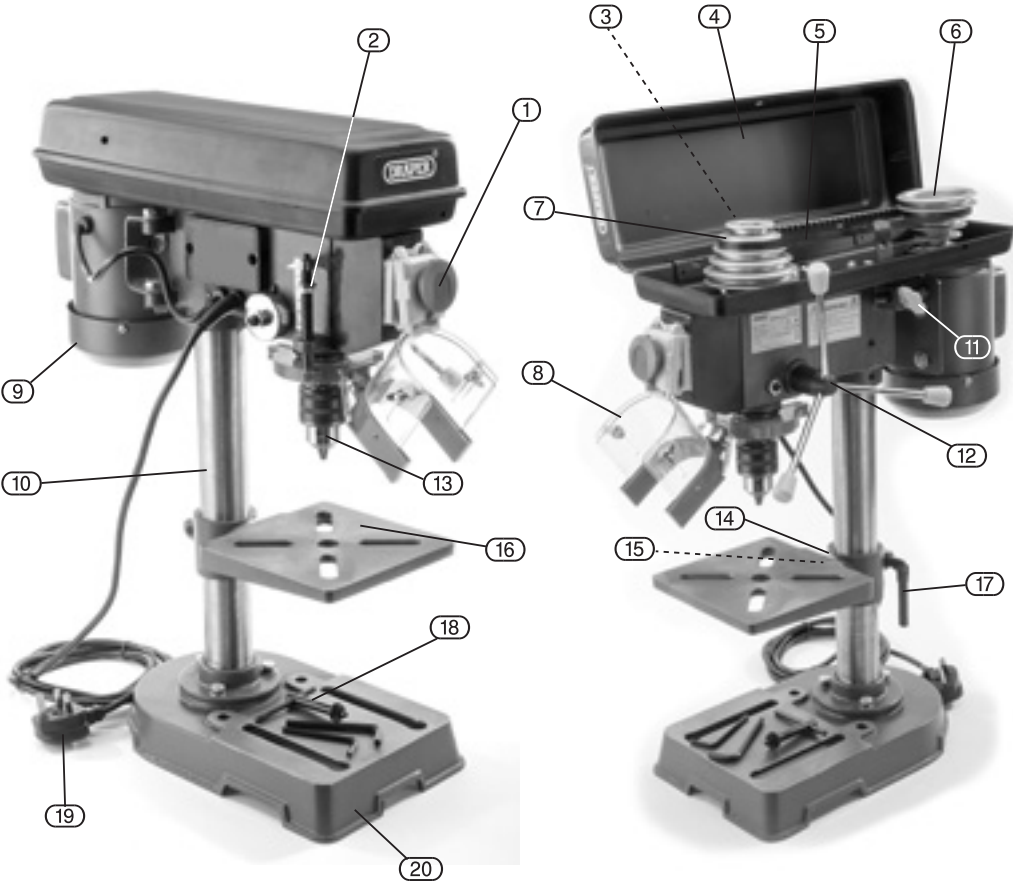

- ① No-volt on/off switch.
- ② Depth stop
- ③ Spindle
- ④ Pulley cover
- ⑤ Motor cut-out microswitch
- ⑥ Motor pulley
- ⑦ Spindle pulley
- ⑧ Guard
- ⑨ Motor
- ⑩ Column
- ⑪ Motor/belt tension adjuster
- ⑫ Plunge handle assembly
- ⑬ Geared chuck
- ⑭ Work table tilt scale
- ⑮ Work table tilt locking bolt
- ⑯ Work table
- ⑰ Work table height/rotation lock
- ⑱ Chuck key
- ⑲ Moulded plug & cable
- ⑳ Base

6. TECHNICAL DESCRIPTION

6.2 MAIN COMPONENT DESCRIPTIONS

The **EMERGENCY STOP BUTTON**; when pushed it will stop all power to the motor. After operating the button it is necessary to release it again to restore the power.

7. UNPACKING & CHECKING

7.1 PACKAGING

Carefully remove the drill from the packaging and examine it for any sign of damage that may have happened during shipping. Lay the contents out and check them against the parts shown below. If any part is damaged or missing; please contact the Draper Helpline (the telephone number appears on the Title page) and do not attempt to use the lathe.

The packaging material should be retained at least during the guarantee period: in case the machine needs to be returned for repair.

Warning! Some of the packaging materials used may be harmful to children. Do not leave any of these materials in the reach of children.

If any of the packaging is to be thrown away, make sure they are disposed of correctly; according to local regulations.

7.2 WHAT'S IN THE BOX?

As well as the drill; there are several parts not fitted or attached to it.

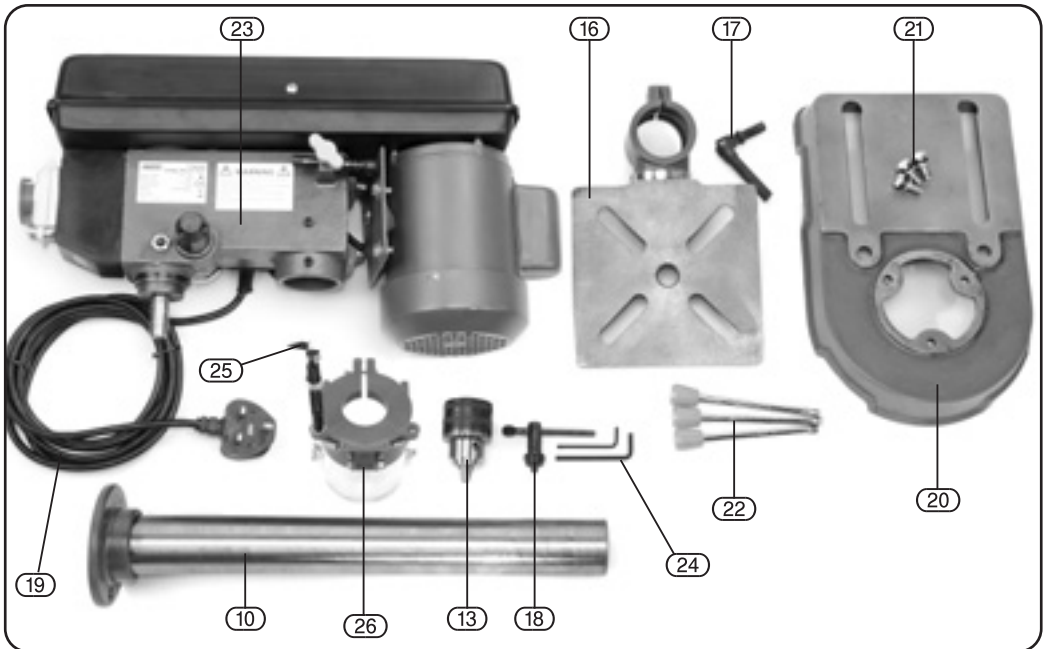

- | | | |
|--|----------------------------|----------------------|
| (10) Column. | (19) Moulded Plug & Cable. | (25) Depth scale. |
| (13) Geared Chuck. | (20) Base. | (26) Guard assembly. |
| (16) Work Table. | (21) Bolts and washers. | |
| (17) Work Table Height /Rotation Lock. | (22) Plunger handles. | |
| (18) Chuck Key. | (23) Body. | |
| | (24) Hexagonal keys. | |

8. PREPARING THE BENCH DRILL

NOTE: Remove the plug from the socket before carrying out adjustment, servicing or maintenance.

8.1 BASE TO COLUMN - FIG. 1

Align the column (10) onto the base (20) and secure with the three 12mm bolts and washers (21).

NOTE: Do not overtighten the bolts as this may crack the flange.

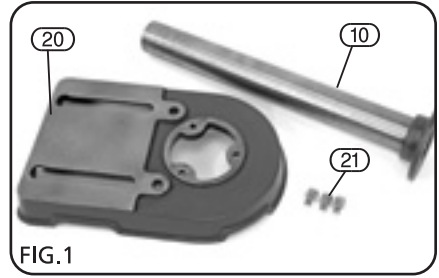

FIG.1

8.2 TABLE - FIG. 2

Pass the table bracket (16) over the column and secure the locking lever (17).

NOTE: Adjust the height to suit and position the table centrally over the base.

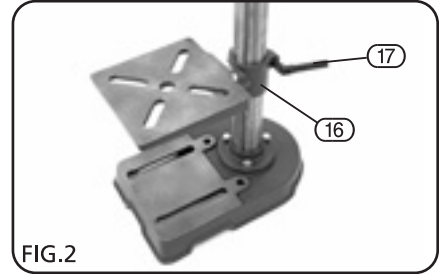

FIG.2

8.3 HEAD - FIG. 3

Lift the head (23) onto the top of the column. When aligned and located fully tighten grub screw with the hexagon key supplied.

NOTE: Adjust the drill head over the table and base before securing.



FIG.3

8.4 PLUNGE HANDLES - FIG. 4

Screw the three plunge handles (22) into the pinion shaft (12).

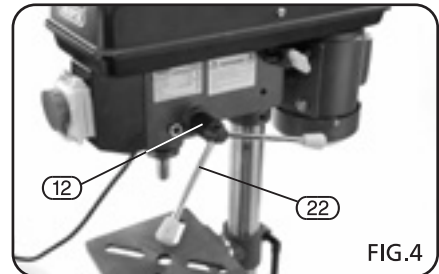

FIG.4

8. PREPARING THE BENCH DRILL

8.5 CHUCK - FIG. 5

Ensure both mating surfaces of the spindle (13A) and chuck (13) are clean before pushing the chuck (13) onto the taper. A sharp tap with a soft blow mallet will secure the chuck in place.

NOTE: Ensure the chuck jaws are fully recessed prior to striking with the mallet.

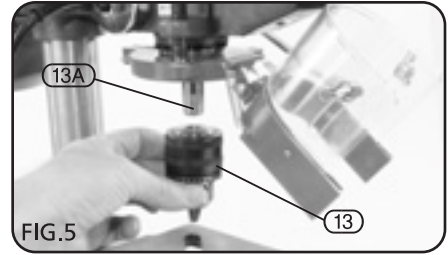

8.6 CHUCK GUARD - FIG. 6

Loosen the cross slot machine screw and nut. Pass the chuck guard assembly (26) over the chuck onto collar (13A). When located fully and aligned on the collar, tighten the machine screw and nuts to secure the chuck guard in place.

Secure the fixings but do not overtighten.

NOTE: The chuck guard shall be inspected before each use to determine effectiveness and correct functionality.

The chuck guard shall be adjusted and positioned between the chuck and operator for all processes. Replace a damaged or missing chuck guard before continuing to use the drilling machine.

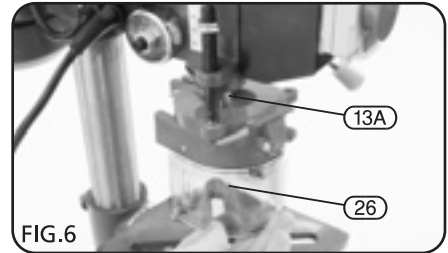

8.7 BENCH MOUNTING

Securely bolt the drilling machine to a work bench or other secure surface through the various points in the base (fixings are not supplied). Ensure there is enough clear space around the drilling machine to accommodate larger items which may be drilled.

9. SETTING THE BENCH DRILL

NOTE: Remove the plug from the socket before carrying out adjustment, servicing or maintenance.

9.1 SPINDLE SPEED ADJUSTMENT - FIGS. 7 & 8

This drilling machine is equipped with 5 drilling speeds.

Remove the pulley cover securing screw (4A). Select the speed most suitable for the intended application†.

Loosen the motor/belt tension adjuster (11) releasing the tautness across the drive belt.

Move the belt to the corresponding sections of the motor and spindle pulleys ensuring the belt remains horizontal.

Apply pressure to the motor mounting plate (9A) to tension the drive belt. With the correct tension achieved lock in position with the motor/belt tension adjuster (11).

Gently lower the pulley cover before tightening pulley cover securing screw (4A).

Never attempt to operate the drilling machine with the pulley cover open or not fully secured.

CAUTION: Over tensioning the drive belt will accelerate belt wear, increase the loading on drive bearings and the motor possibly leading to premature failure. Under tensioning the drive belt will lead to the drive belt slipping and increased noise.

†As a general rule material with a softer composition can be drilled faster as they cut more easily. Harder materials require a slower speed as attempting to make the hole at a high speed will result in the drill bit over heating which may result in a poorly finished hole, the bit annealing or the bit breaking. Drilling wood too slowly can cause splintering.

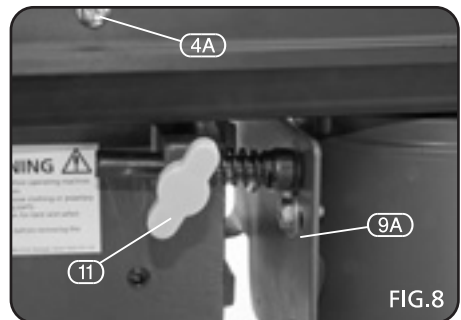
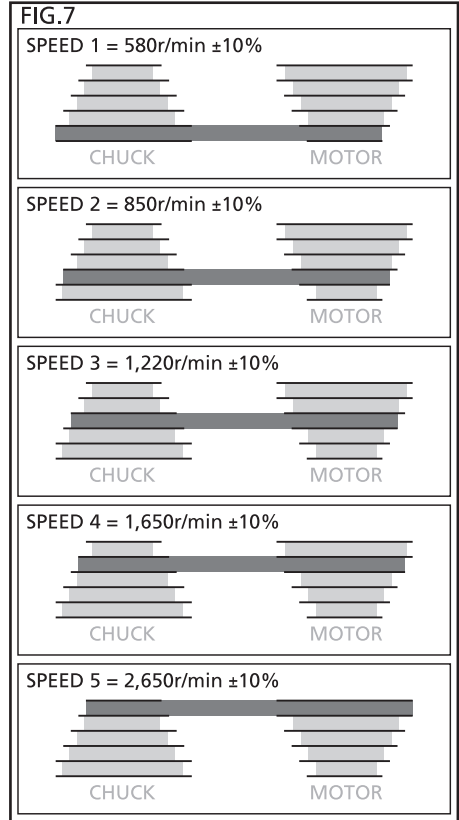

9. SETTING THE BENCH DRILL

9.2 DRILL BIT INSTALLATION/ REPLACEMENT - FIG. 9

The drilling machine is equipped with a geared chuck and a separate key to secure the bit in the chuck jaws.

Selection of the correct accessory is dependent on material type and the intended application.

Ensure the selected accessory is suitable and speed compatible with the drilling machine.

Place the bit into the chuck. Insert the chuck key (18) into apertures (13) engaging the teeth.

Rotate the key clockwise to grip. All three apertures should be tightened to make certain of a firm grip.

Always use a good quality sharp drill bit.

WARNING: The drill bit will be hot after use.

9.3 NO-VOLT SWITCH - FIG. 10

In the event of a power supply disruption, the machine will require manually restarting once power has been returned.

To switch the machine 'ON', press the green button marked 'I'.

To switch the machine 'OFF', press the red button marked 'O'. Prior to starting the drilling machine make a visual check, to ensure the guards are in place and correctly functioning, the bit is correctly installed with the chuck key removed and no other parts are damaged proving a potential hazard.

9.4 WORK TABLE ADJUSTMENT - FIG. 11

For versatility the work table (16) can be raised or lowered, tilted $\pm 45^\circ$ or rotated 180° .

To tilt the table, loosen the 19mm bolt (15).

Adjust the table's degree of tilt and secure with locking bolt (15). Use scale (14) as a guide.

To raise/lower the table working height, loosen locking lever (17). Alternatively the table can be rotated 180° to further increase the distance between the chuck and workpiece. When the adjustments are complete re-secure locking lever (17).

The slots (16A) in the work table and base (20A) can accommodate locking bolts to secure a small vice enabling safe clamping of the workpiece.

CAUTION: A drill bit snagging on a piece of work will violently grab the piece of material, whipping it round and is likely to result in personal injury.

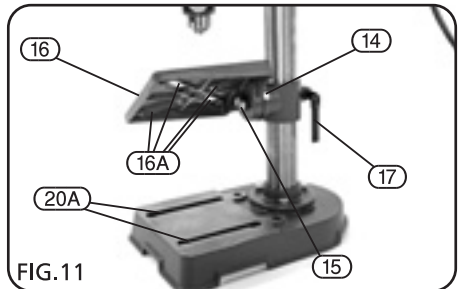
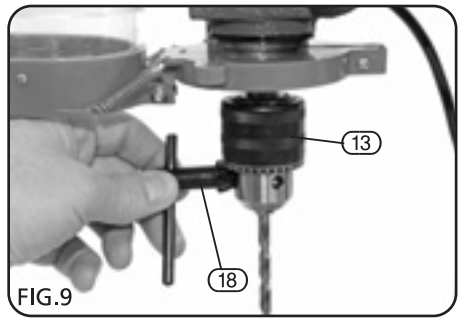

9. SETTING THE BENCH DRILL

9.5 GENERAL DRILLING - FIG. 12

For repeat drilling to a consistent depth set the depth stop facility (2).

The depth is indicated against guide (2D).

NOTE: For more accuracy set up the depth using a steel rule.

Lower the chuck and drill bit to the required position by rotating the plunge handles (12) anti-clockwise.

Set the position with nut (2B) against the stop (2C) and lock with nut (2A).

Use a scrap piece of material to test before beginning on the workpiece.

When drilling metal it is good practice to use a cutting fluid to aid lubrication, swarf removal and as a coolant.

This will result in increased cutting performance and help prolong the life of the bit. A few drops of oil will suffice in the absence of a specific cutting fluid.

9.6 DUST AND SWARF

All wood dust (including dust from composites like chipboards and fibre boards etc) is hazardous to health: it can affect the nose, the respiratory system and the skin. For example MDF (medium density fibreboard) which contains formaldehyde is a known carcinogen.

A correctly fitted dust mask, suitable for the activity and in accordance to the relevant standard, must be worn.

For work activities involving exposure to fine wood dust a mask rated to at least FFP2 should be used.

Swarf produced by metal cutting is extremely sharp. Take care when breaking the chips/clearing the bit.

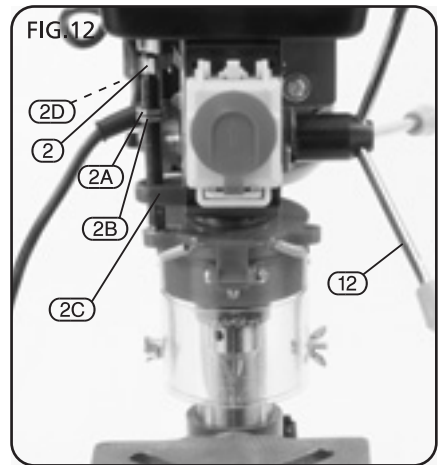

10. TROUBLESHOOTING

WARNING: For your safety always turn the main switch on the machine "off" and remove the plug from the power supply before carrying out any maintenance or troubleshooting.

Problem	Cause	Remedy
Machine will not start.	<ol style="list-style-type: none">1. Fuse.2. Other.	<ol style="list-style-type: none">1. Replace/reset time delay fuse or circuit breaker.2. Return to an authorised service agent for diagnosis.
Noisy operation.	<ol style="list-style-type: none">1. Incorrect belt tension.2. Dry spindle.3. Loose spindle pulley or motor pulley.	<ol style="list-style-type: none">1. Adjust tension.2. Lubricate spindle with grease.3. Tighten set screws in pulleys.
Bit burns or smokes.	<ol style="list-style-type: none">1. Incorrect speed.2. Swarf not coming out of hole.3. Blunt bit.4. Feeding too slow.5. Not lubricated.	<ol style="list-style-type: none">1. Change speed.2. Retract bit frequency to clear swarf.3. Sharpen or replace bit.4. Feed fast enough to allow drill to cut.5. Lubricate bit.
Excessive drill run-out or wobble.	<ol style="list-style-type: none">1. Bent bit.2. Worn spindle bearings.3. Bit not properly installed in chuck.4. Chuck not properly installed.	<ol style="list-style-type: none">1. Use a straight bit.2. Return to an authorised service agent.3. Install bit centrally.4. Refit chuck properly.
Drill binds in workpiece.	<ol style="list-style-type: none">1. Workpiece pinching bit or excessive feed pressure.2. Improper belt tension.	<ol style="list-style-type: none">1. Support or re-clamp workpiece.2. Adjust tension.

11. MAINTENANCE

Regular inspection and cleaning reduces the necessity for maintenance operations and will keep your tool in good working condition.

The motor must be correctly ventilated during tool operation. For this reason avoid blocking the air inlets. After use disconnect the tool from the power supply and vacuum the ventilation slots.

If the replacement of the supply cord is necessary, this has to be done by the manufacturer or his agent in order to avoid a safety hazard.

At regular interval, lubricate the spindle with a medium purpose grease. With the pulley cover open, pack the grease down the centre of the front pulley. Operate the plunger mechanism and brush a thin film of grease on the quill. Clean any debris built up in the pulley housing. Spray a general purpose lubricating agent/rust inhibitor on the other moving parts and machined surfaces.

12. ACCESSORIES

A range of drill bits and accessories are available from your local Draper Stockist.

DRILL PRESS VICES:

Stock No.	Jaw Width	Jaw Opening
40390	70mm	67mm
64585	85mm	100mm

13. DISPOSAL

13.1 DISPOSAL

- At the end of the machine's working life, or when it can no longer be repaired, ensure that it is disposed of according to national regulations.
- Contact your local authority for details of collection schemes in your area.

In all circumstances:

- Do not dispose of power tools with domestic waste.
- Do not incinerate.
- Do not abandon in the environment.
- Do not dispose of WEEE* as unsorted municipal waste.



* Waste Electrical & Electronic Equipment.

14. EXPLANATION OF SYMBOLS

14.1 EXPLANATION OF SYMBOLS



Warning!
Do not wear loose clothing.



Warning!
Read the instruction manual



Warning!
Wear ear defenders.
Wear goggles.
Wear dust mask.



Warning!
Keep hands away for blade.



Warning!
Do not wear gloves.



Warning! Disable the machine
before attempting to maintain it.



WEEE
Do not dispose of Waste Electrical
& Electronic Equipment in with
domestic rubbish

- **DRAPER TOOLS LIMITED,**
Hursley Road, Chandler's Ford,
Eastleigh, Hampshire. SO53 1YF. U.K.
- **Helpline:** (023) 8049 4344
- **Sales Desk:** (023) 8049 4333
- **Internet:** www.drapertools.com
- **E-mail:** sales@drapertools.com
- **Sales Fax:** (023) 8049 4209
- **General Enquiries:** (023) 8026 6355
- **Service/Warranty Repair Agent**
For aftersales servicing or warranty repairs, please contact the Draper Tools Helpline for details of an agent in your local area.

YOUR DRAPER STOCKIST