

**DRAPER**<sup>®</sup>

SPARE PARTS LISTING SHEET FOR

# 350W 230V 5 Speed Hobby Bench Drill

Stock No.38255

Part No.D13/5DA

KEY No.	PART No.	STOCK No.	DESCRIPTION
1	YD13/5DA - 01	51769	Base
2	YD13/5DA - 02	51771	Column support
3	YD13/5DA - 03	51772	Washer M8
4	YD13/5DA - 04	51773	Spring washer M8
5	YD13/5DA - 05	51774	Hex bolt M8 x 20
6	YD13/5DA - 06	51775	Column
7	YD13/5DA - 07	51776	Handle knob
8	YD13/5DA - 08	51777	Handle bar
9	YD13/5DA - 09	51779	Feed shaft
10	YD13/5DA - 10	51780	Socket head cap screw M8 x 10
11	YD13/5DA - 11	51781	Locking handle
12	YD13/5DA - 12	51782	Spring
13	YD13/5DA - 13	51784	Slide bar
14	YD13/5DA - 14	51785	Cushioning
15	YD13/5DA - 15	51786	Motor
16	YD13/5DA - 16	51787	Hex bolt M8 x 18
17	YD13/5DA - 17	51789	Socket head cap screw M6 x 10
18	YD13/5DA - 18	51790	Motor pulley
19	YD13/5DA - 19	51791	Housing
20	YD13/5DA - 20	51792	Special screw
21	YD13/5DA - 21	51793	Washer
22	YD13/5DA - 22	51795	Gear washer
23	YD13/5DA - 23	51796	Shake-proof washer
24	YD13/5DA - 24	51798	Power plug
25	YD13/5DA - 25	51799	V-belt
26	YD13/5DA - 26	51800	Belt cover assembly
27	YD13/5DA - 27	51801	Pressing paw
28	YD13/5DA - 28	51816	Hex nut M6
29	YD13/5DA - 29	51817	Micro switch cover
30	YD13/5DA - 30	51818	Big washer
31	YD13/5DA - 31	51819	Screw M6 x 16
32	YD13/5DA - 32	51828	Micro switch
33	YD13/5DA - 33	51832	Self-tapping screw
34	YD13/5DA - 34	51838	Micro switch plate
35	YD13/5DA - 35	51856	Self-tapping screw
36	YD13/5DA - 36	51861	Self-tapping screw
37	YD13/5DA - 37	51863	Cord anchorage
38	YD13/5DA - 38	51873	Screw M6 x 12
39	YD13/5DA - 39	51884	Cord anchorage
40	YD13/5DA - 40	51885	Spindle pulley
41	YD13/5DA - 41	51886	Circlip

KEY No.	PART No.	STOCK No.	DESCRIPTION
42	YD13/5DA - 42	51887	Spine sleeve
43	YD13/5DA - 43	51888	Circlip
44	YD13/5DA - 44	51889	Bearing
45	YD13/5DA - 45	51890	Rubber cable sleeve
46	YD13/5DA - 46	51891	Hex nut M10
47	YD13/5DA - 47	51892	Coil spring cover
48	YD13/5DA - 48	51893	Coil spring
49	YD13/5DA - 49	51894	Scale label
50	YD13/5DA - 50	51895	Switch box
51	YD13/5DA - 51	51897	Washer
52	YD13/5DA - 52	51898	Screw M5 x 10
53	YD13/5DA - 53	51899	Switch
54	YD13/5DA - 54	51900	Screw
55	YD13/5DA - 55	51901	Pointer
56	YD13/5DA - 56	51902	Limit bolt
57	YD13/5DA - 57	51903	Screw M8 x 4
58	YD13/5DA - 58	51904	Spring washer
59	YD13/5DA - 59	51905	Earthing
60	YD13/5DA - 60	51906	Gear washer
61	YD13/5DA - 61	51907	Screw M8 x 16
62	YD13/5DA - 62	51908	Hex nut M8
63	YD13/5DA - 63	51909	Table bracket
64	YD13/5DA - 64	51910	Angle scale
65	YD13/5DA - 65	51913	Table
66	YD13/5DA - 66	51914	Spring washer
67	YD13/5DA - 67	52246	Nut M12x25
68	YD13/5DA - 68	52247	Circlip
69	YD13/5DA - 69	52249	Bearing
70	YD13/5DA - 70	52250	Main spindle
71	YD13/5DA - 71	52251	Spindle sleeve
72	YD13/5DA - 72	52252	Cushioning washer
73	YCG40A	52253	Chuck
74	YGC13A	52254	Chuck guard
75	YD13/5DA - 75	52255	Clamping lever A
76	YD13/5DA - 76	52256	Chuck key
77	YD13/5DA - 77	52257	Hex key 3mm
78	YD13/5DA - 78	52258	Hex key 4mm
79	YD13/5DA - 79	52259	Washer
80	YD13/5DA - 80	52260	Motor base
81	YD13/5DA - 81	52261	Spring washer
82	YD13/5DA - 82	52262	Spring washer

**Helpline: (023) 8049 4344. Sales Desk: (023) 8049 4333. General Enquiries: (023) 8026 6355.**

DRAPER TOOLS LTD, HURSLEY ROAD, CHANDLER'S FORD, EASTLEIGH, HANTS. SO53 1YF. U.K. internet: www.drapertools.com e-mail: sales@drapertools.com



SPARE PARTS DRAWING SHEET FOR

# 350W 230V 5 Speed Hobby Bench Drill

Stock No.38255 Part No.D13/5DA

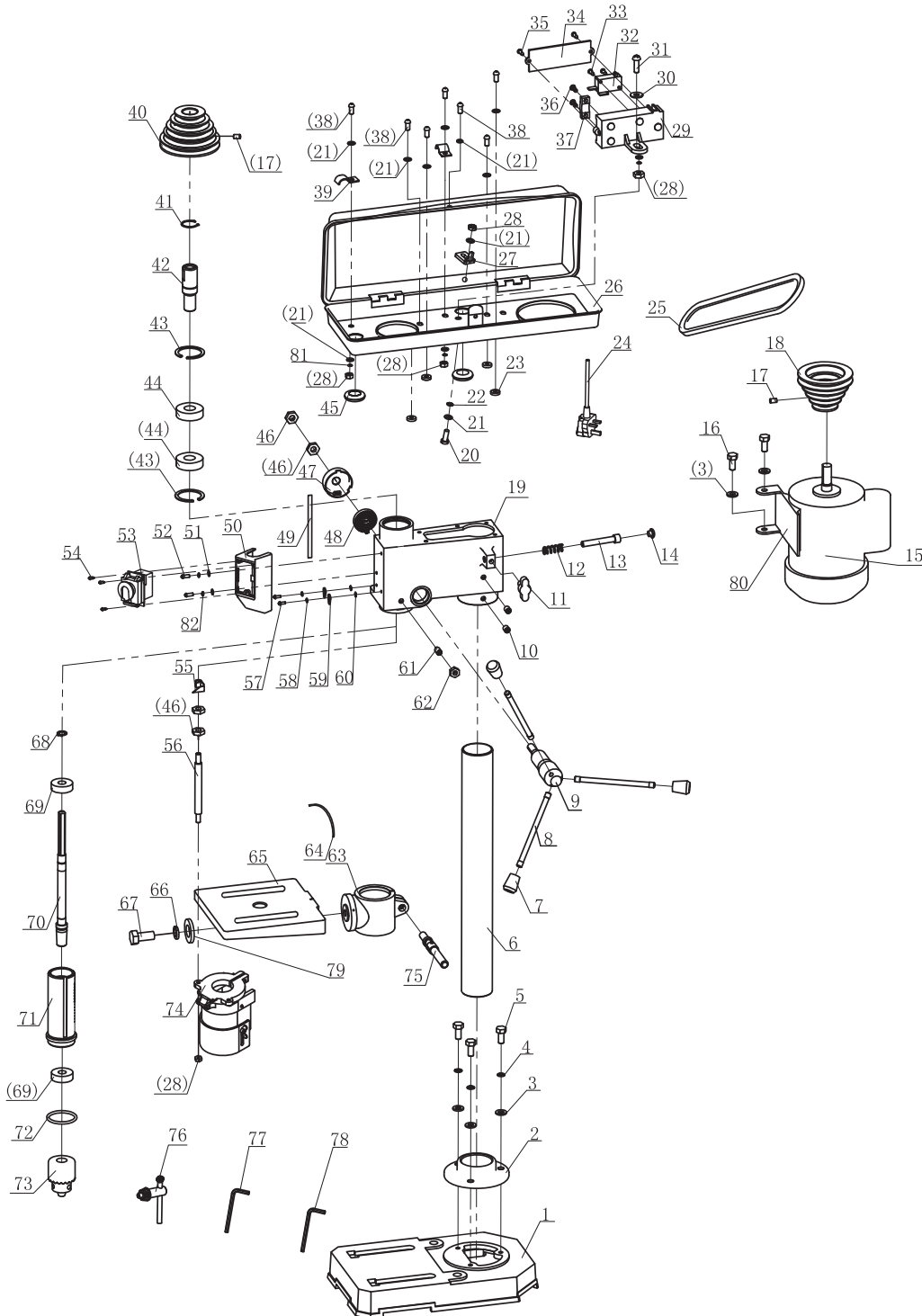

**Helpline: (023) 8049 4344. Sales Desk: (023) 8049 4333. General Enquiries: (023) 8026 6355.**

DRAPER TOOLS LTD, HURSLEY ROAD, CHANDLER'S FORD, EASTLEIGH, HANTS. SO53 1YF. U.K. internet: [www.drapertools.com](http://www.drapertools.com) e-mail: [sales@drapertools.com](mailto:sales@drapertools.com)