



LEVER ACTION BARREL PUMP

47808

IMPORTANT: PLEASE READ THESE INSTRUCTIONS CAREFULLY TO ENSURE THE SAFE AND EFFECTIVE USE OF THIS PRODUCT.



INSTRUCTIONS

These instructions accompanying the product are the original instructions. This document is part of the product, keep it for the life of the product passing it on to any subsequent holder of the product. Read all these instructions before assembling, operating or maintaining this product.

This manual has been compiled by Draper Tools describing the purpose for which the product has been designed, and contains all the necessary information to ensure its correct and safe use. By following all the general safety instructions contained in this manual, it will ensure both product and operator safety, together with longer life of the product itself.

All photographs and drawings in this manual are supplied by Draper Tools to help illustrate the operation of the product.

Whilst every effort has been made to ensure the accuracy of information contained in this manual, the Draper Tools policy of continuous improvement determines the right to make modifications without prior warning.

1. INTRODUCTION

1.1 SCOPE

This Lever Action Barrel Pump is a hand operated heavy duty pump designed to transfer oil based fluids, heating oils, motor oils, diesel oil, kerosene, heavy & light oils

The pump comes complete with self adjusting telescopic suction tube, curved metal spout, and 1½" & 2" bung nut.

1.2 SPECIFICATION

Stock No's.	47808
Part No's.	BP/G
Barrel size	1½" & 2" bung adaptor
Delivery rate	up to 300ml(10oz. per stroke)
Non return seal	NBR
Wetted components.....	Steel, Aluminium, Zinc, Brass & NBR.

Recommended use: .. Oil base fluids, heating oils, motor oils, diesel oil, kerosene, heavy & light oils.

Do not use: Water based fluids, solvents, acid, antifreeze or fluids that cause corrosion.

2. HEALTH AND SAFETY INFORMATION

2.1 GENERAL SAFETY INFORMATION

To ensure safe and efficient operation, it is essential to read and follow each of these warnings and precautions.

1. Improper use or installation of this product can cause serious bodily injury or death.
2. Do NOT smoke near pump or use pump near an open flame. Fire could result.
3. When pumping flammable liquids, all equipment must be grounded to prevent the accumulation of static electricity which may ignite vapours or gases.
4. The pump and containers should be connected using bonding clamps or clips and a conductive wire no smaller than 12 gauge. A secure and positive metal-to-metal contact must be made. The other end of the wire should be attached to a good ground, such as a steel building column or water pipe.

Warning: Leave handle in upright position when not in use.

3. TECHNICAL DESCRIPTION

3.1 IDENTIFICATION

- ① Pivot Pin & retainer clip.
- ② Plunger rod.
- ③ Lever handle.
- ④ Delivery spout
- ⑤ Compression nut.
- ⑥ Spout nut.
- ⑦ Pump head.
- ⑧ Rubber grip.
- ⑨ Pump body.
- ⑩ Bung nut.
- ⑪ Suction tube assembly.

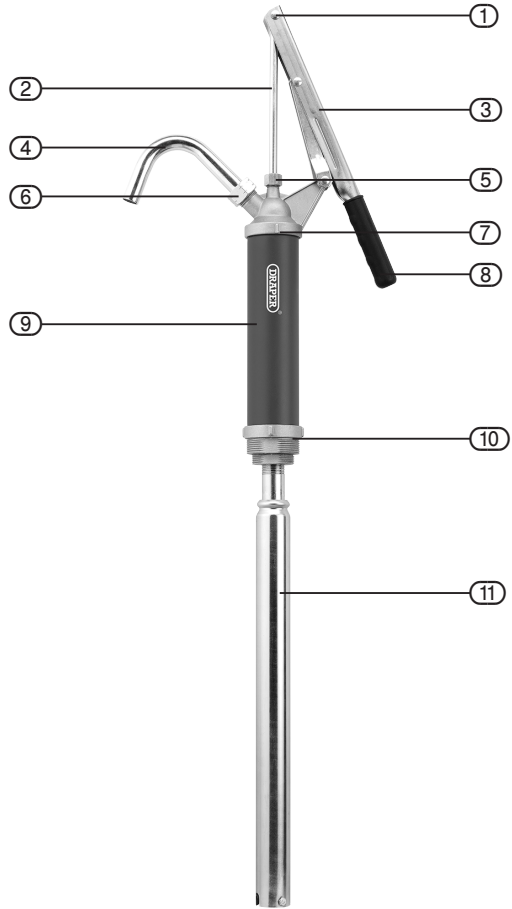

4. ASSEMBLY

4.1 ASSEMBLY

1. Screw the suction tube assembly into the bung nut (⑩). Tighten the connection securely to eliminate any air leaks.
2. Screw the delivery spout nut (⑥) (part of the spout) onto the pump head. Tighten securely to eliminate any possibility of leakage.
3. Extend the telescopic suction pipe (⑪) little longer than the height of the drum.
4. Screw the pump into the drum's bung. Tighten the pump assembly securely by grasping the pump body (⑨) and rotating.
5. Pull the plunger rod (②) of piston sub assembly up and attach the lever handle to the piston rod using the pivot pin and retainer clip (①).

5. OPERATION



5.1 OPERATION

Now the pump is ready, start operating the pump by giving quick strokes to the lever handle.

NOTE:

1. Apply thread sealant to the threads of the suction tube assembly before attaching it to the bung nut. Do not use undue force when tightening.
2. Ensure rubber gasket is positioned properly in spout nut (6) before attaching the Delivery spout (4).
3. The telescopic suction tube will automatically adjust to the proper position.
4. Do not tighten the pump by holding the lever handle (3).
5. Ensure that the retainer clip is bent properly so as eliminate possibility of pivot pin coming out while using the pump.

NOTE: The pump is constructed using plated steel components. It should never be used to transfer fluids that may cause the pump to rust. Certain fluids have a tendency to build a coating on the surface when dry, it is recommended to leave the lever handle in upright position when not in use.

5.2 PRIME THE PUMP

If the pumps fails to operate, it may be necessary to prime.

Turn the delivery spout upward.

Pour a few drops of the fluid being dispensed into the spout.

Start the pump by moving the lever with several quick strokes.

If the pump still fails to start:

Remove the pump from the drum and ensure the Suction tube is extended enough to reach the bottom of the drum.

CONTACTS

Draper Tools Limited, Hursley Road,
Chandler's Ford, Eastleigh, Hampshire. SO53 1YF. U.K.

Helpline: (023) 8049 4344

Sales Desk: (023) 8049 4333

Internet: drapertools.com

E-mail: sales@drapertools.com

General Enquiries: (023) 8026 6355

Service/Warranty Repair Agent:

For aftersales servicing or warranty repairs, please contact the Draper Tools Helpline for details of an agent in your local area.

SRMC0218

©Published by Draper Tools Limited.

No part of this publication may be reproduced, stored in a retrieval system or transmitted in any form or by any means, electronic, mechanical photocopying, recording or otherwise without prior permission in writing from Draper Tools Ltd.

YOUR DRAPER STOCKIST