

DRAPER®

12L

KNAPSACK PRESSURE SPRAYER

63056

IMPORTANT: PLEASE READ THESE INSTRUCTIONS CAREFULLY TO ENSURE THE SAFE AND EFFECTIVE USE OF THIS PRODUCT.



INSTRUCTIONS

These instructions accompanying the product are the original instructions. This document is part of the product, keep it for the life of the product passing it on to any subsequent holder of the product. Read all these instructions before assembling, operating or maintaining this product.

This manual has been compiled by Draper Tools describing the purpose for which the product has been designed, and contains all the necessary information to ensure its correct and safe use. By following all the general safety instructions contained in this manual, it will ensure both product and operator safety, together with longer life of the product itself.

All photographs and drawings in this manual are supplied by Draper Tools to help illustrate the operation of the product.

Whilst every effort has been made to ensure the accuracy of information contained in this manual, the Draper Tools policy of continuous improvement determines the right to make modifications without prior warning.

1. SPECIFICATION

1.1 SCOPE

For use with water, herbicides, pesticides and solvent-free preservative treatments.

1.2 SPECIFICATION

Stock no. 63056
Part no. PS12K
Bottle capacity 15L
Working capacity 12L

2. HEALTH & SAFETY INFORMATION

2.1 GENERAL SAFETY WARNINGS

⚠ WARNING: READ and UNDERSTAND the instructions completely before using these sprayers. The user must always ask the dealer for the safety card of the chemical product to be used, also for disposal of the residual liquid. The use of substances not in conformity with the current regulations is at the user's risk and peril.



Never open the pump when under pressure.



Do not eat, drink or smoke during use.



Do not leave the sprayer exposed to heat sources or intense cold.



Do not spray on windy days.



Do not use for spraying food products (wine, milk, etc.).



Wash hands and face after use.



Do not spray toxic or harmful liquids on persons, animals or foodstuffs.



Do not leave pump within the reach of children.



Use suitable protection equipment during use.



Keep bystanders away whilst using the sprayer.

NOTE: After use, rinse the container then operate the pump with clean water to completely empty the container and piston.

3. TECHNICAL DESCRIPTION

3.1 IDENTIFICATION

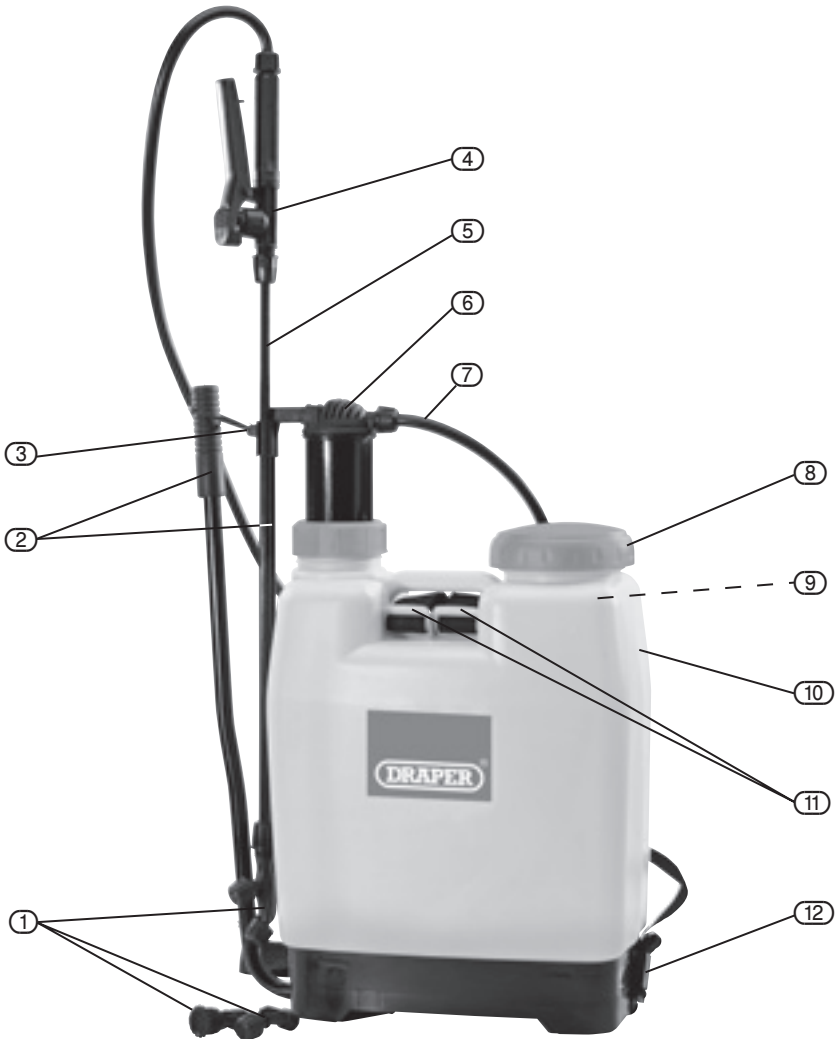

- ① Nozzles (x3)
- ② Pump lever arm
- ③ Lance + Pump lever arm support
- ④ Trigger assembly
- ⑤ Lance
- ⑥ Pump piston

- ⑦ Hose
- ⑧ Filler cap
- ⑨ Integral filter
- ⑩ Tank
- ⑪ Strap buckles
- ⑫ Strap + adjustment clips

4. UNPACKING & CHECKING

4.1 PACKAGING

Carefully remove the product from the packaging and examine it for any sign of damage that may have happened during shipping. Lay the contents out and check them against the parts shown below. If any part is damaged or missing; please contact the Draper Helpline (the telephone number appears on the Title page) and do not attempt to use the product.

The packaging material should be retained at least during the guarantee period: in case the machine needs to be returned for repair.

Warning! Some of the packaging materials used may be harmful to children. Do not leave any of these materials in the reach of children.

If any of the packaging is to be thrown away, make sure they are disposed of correctly; according to local regulations.

4.2 WHAT'S IN THE BOX?

There are a number of parts in the box which need to be assembled.

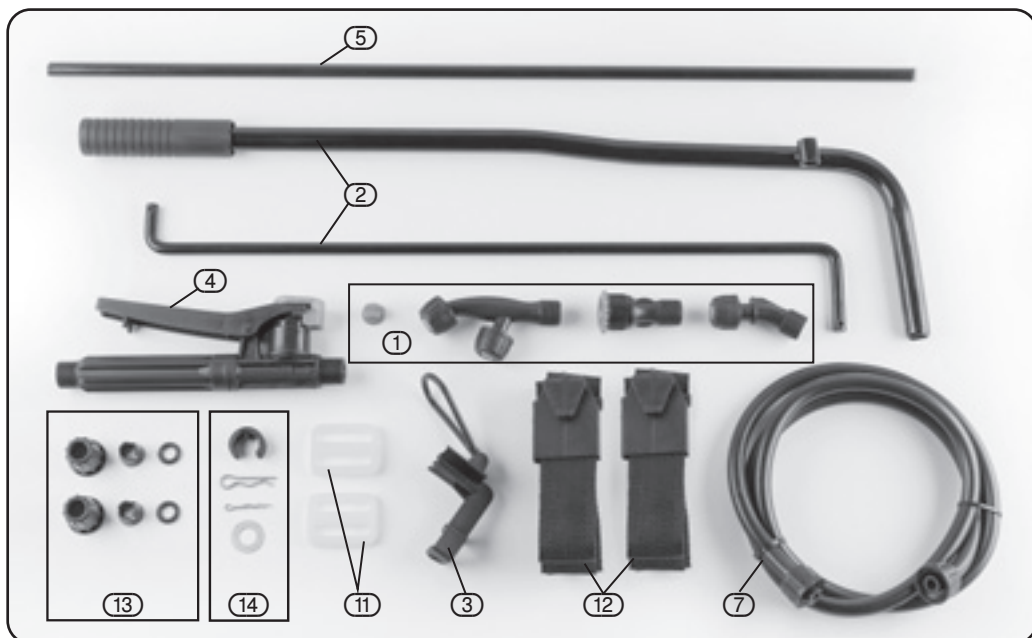

(13) Lance/nozzle connectors

(14) Lever arm accessories

5. ASSEMBLY

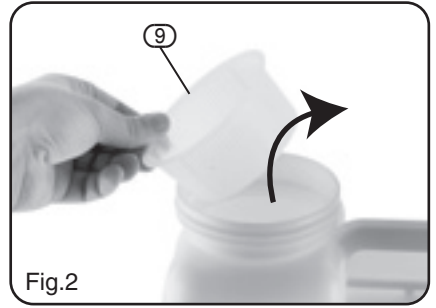
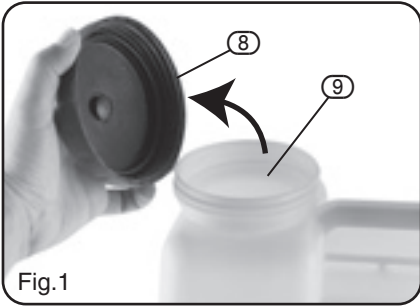

Small parts stored inside.

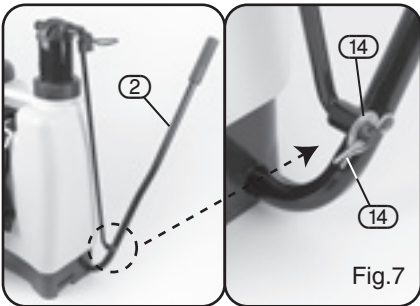
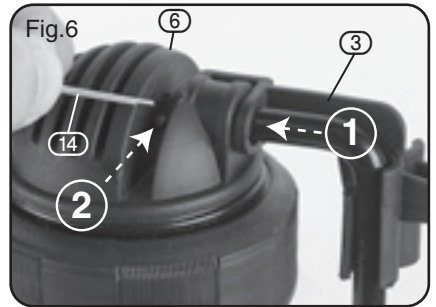
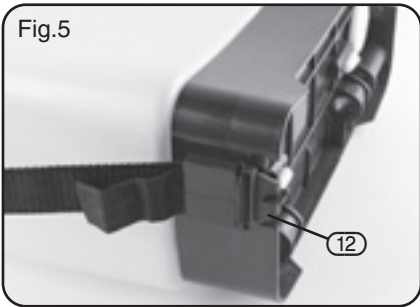
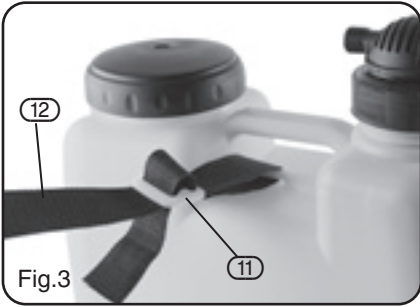

5. ASSEMBLY

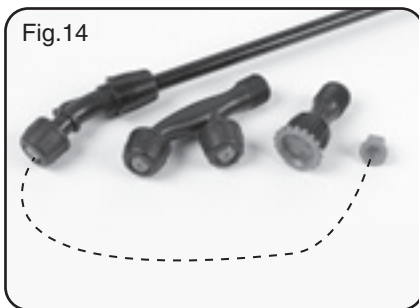
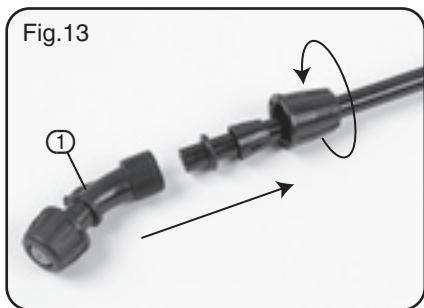
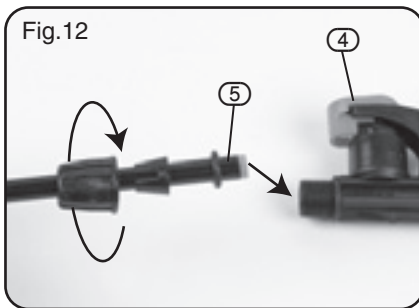
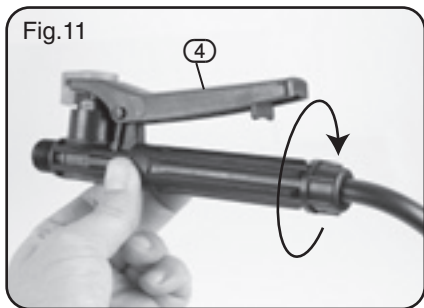
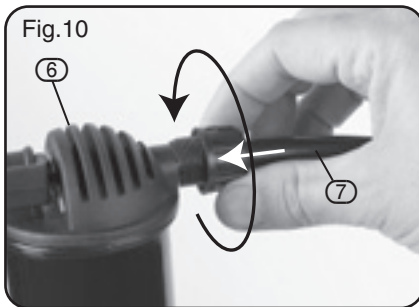
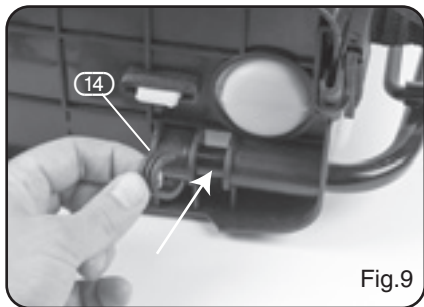

5. OPERATION AND USE

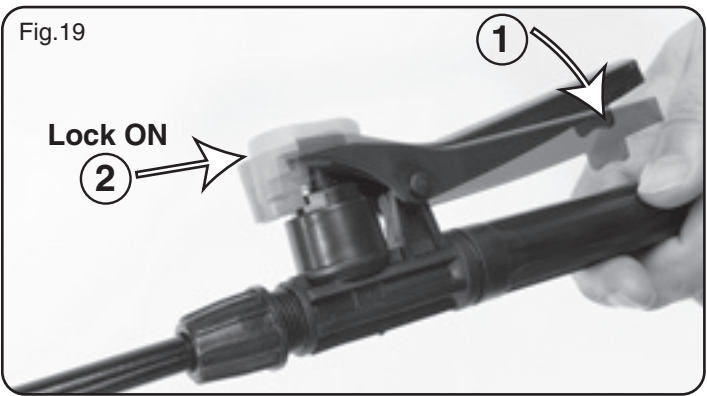

6. MAINTENANCE

CLEANING THE BACKPACK SPRAYER:

Press the trigger on the sprayer handle to release the pressure remaining through the lance.

Unscrew tank cap, if the outside of the cap is dirty, thoroughly clean the area around the thread and thread O-ring.

Clean the inlet filter and tank cap in clean water.

Empty the tank and fill with clean water (with detergent added to the water if necessary).

Spray the water out of the backpack sprayer until the tank is empty (This cleans the nozzle and valves).

Leave the backpack sprayer open and allow it to dry.

CLEANING THE FILTER IN THE SPRAYER HANDLE:

Unscrew the union nut and pull the hose with filter out of the sprayer handle.

Rinse the filter under running water and reattach the sprayer handle.

CLEANING THE PUMP:

If the pump does not provide pressure after cleaning your backpack sprayer you must also clean the pump.

Push out the locking ring (using a screwdriver, for example) and pull the joint rod out of the pump.

Unscrew the union ring and pull out the pump.

Inspect the pump O-ring and install a new O-ring if necessary.

Pull out the inner part of the pump and the gasket.

Clean all pump parts and gaskets with water (and detergent).

Reassemble the pump in the reserve order.

NOTE: When assembling the pump ensure that the pump gaskets are seated properly after installation and are not squashed.

At least once a year clean pump thoroughly, re-grease or lubricate all moving parts.

WARNING:

When assembling and servicing, carefully insert the pump piston without forcing, so as not to damage the gasket.

CONTACTS

- **DRAPER TOOLS LIMITED,**
Hursley Road, Chandler's Ford,
Eastleigh, Hampshire. SO53 1YF. U.K.
- **Helpline:** (023) 8049 4344
- **Sales Desk:** (023) 8049 4333
- **Internet:** www.drapertools.com
- **E-mail:** sales@drapertools.com
- **Sales Fax:** (023) 8049 4209
- **General Enquiries:** (023) 8026 6355
- **Service/Warranty Repair Agent**
For aftersales servicing or warranty repairs, please
contact the Draper Tools Helpline for details of an
agent in your local area.

YOUR DRAPER STOCKIST

TACH1216

©Published by Draper Tools Limited.

No part of this publication may be reproduced, stored in a retrieval system or transmitted in any form or by any means, electronic, mechanical photocopying, recording or otherwise without prior permission in writing from Draper Tools Ltd.