

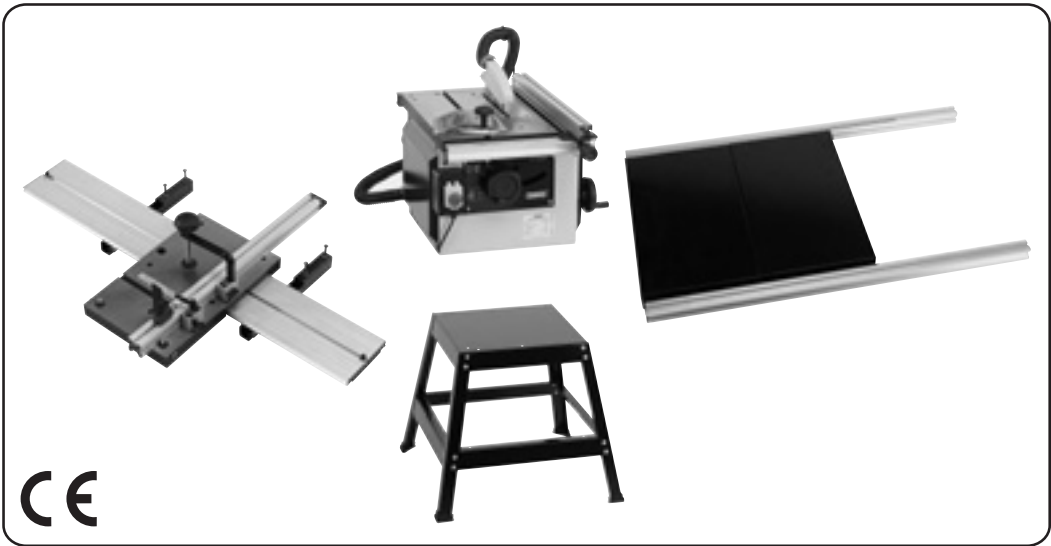

INSTRUCTIONS FOR 200mm 230V Cast Table Saw and Accessories

Stock Nos.82108, 82112, 82110, 82109
Part Nos.CTS200A, ACTS3, ACTS2, ACTS1

IMPORTANT: PLEASE READ THESE INSTRUCTIONS CAREFULLY TO ENSURE THE SAFE AND EFFECTIVE USE OF THIS PRODUCT.



DRAPER[®]

GENERAL INFORMATION

These instructions accompanying the product are the original instructions. This document is part of the product, keep it for the life of the product passing it on to any subsequent holder of the product. Read all these instructions before assembling, operating or maintaining this product.

This manual has been compiled by Draper Tools describing the purpose for which the product has been designed, and contains all the necessary information to ensure its correct and safe use. By following all the general safety instructions contained in this manual, it will ensure both product and operator safety, together with longer life of the product itself.

All photographs and drawings in this manual are supplied by Draper Tools to help illustrate the operation of the product.

Whilst every effort has been made to ensure the accuracy of information contained in this manual, the Draper Tools policy of continuous improvement determines the right to make modifications without prior warning.

1. TITLE PAGE

1.1 INTRODUCTION:

USER MANUAL FOR:

200mm 230V CAST TABLE SAW AND ACCESSORIES

Stock nos. 82108, 82112, 82110, 82109.

Part noS. CTS200A, ACTS3, ACTS2, ACTS1.

1.2 REVISIONS:

Date first published November 2015

As our user manuals are continually updated, users should make sure that they use the very latest version.

Downloads are available from: <http://www.drapertools.com/manuals>

DRAPER TOOLS LIMITED
HURSLEY ROAD
CHANDLER'S FORD
EASTLEIGH
HAMPSHIRE
SO53 1YF
U.K.

WEBSITE: drapertools.com
PRODUCT HELPLINE: +44 (0) 23 8049 4344
GENERAL FAX: +44 (0) 23 8026 0784

1.3 UNDERSTANDING THIS MANUALS SAFETY CONTENT:

WARNING! Information that draws attention to the risk of injury or death.

CAUTION! Information that draws attention to the risk of damage to the product or surroundings.

1.4 COPYRIGHT © NOTICE:

Copyright © Draper Tools Limited.

Permission is granted to reproduce this publication for personal & educational use only.

Commercial copying, redistribution, hiring or lending is prohibited.

No part of this publication may be stored in a retrieval system or transmitted in any other form or means without written permission from Draper Tools Limited.

In all cases this copyright notice must remain intact.

2. CONTENTS

2.1 CONTENTS

| <i>Page content</i> | <i>Page</i> |
|--|-------------|
| 1 TITLE PAGE | |
| 1.1 INTRODUCTION | 2 |
| 1.2 REVISION HISTORY | 2 |
| 1.3 UNDERSTANDING THIS MANUAL | 2 |
| 1.4 COPYRIGHT NOTICE | 2 |
| 2 CONTENTS | |
| 2.1 CONTENTS | 3 |
| 3 GUARANTEE | |
| 3.1 GUARANTEE | 4 |
| 4 INTRODUCTION | |
| 4.1 SCOPE | 5 |
| 4.2 SPECIFICATION | 5 |
| 4.3 HANDLING & STORAGE | 5 |
| 5 HEALTH & SAFETY INFORMATION | |
| 5.1 GENERAL SAFETY INSTRUCTIONS FOR POWER TOOL USE | 6-7 |
| 5.2 SPECIFIC SAFETY INSTRUCTIONS FOR TABLE SAWS | 7-9 |
| 5.3 CONNECTION TO THE POWER SUPPLY | 9 |
| 6 TECHNICAL DESCRIPTION | |
| 6.1 IDENTIFICATION | 10 |
| 7 UNPACKING & CHECKING | |
| 7.1 PACKAGING | 11 |
| 7.2 WHAT'S IN THE BOX? | 12-14 |
| 8 PREPARING THE TABLE SAW | |
| STAND KIT Stock No.82110 | |
| 8.1 STAND ASSEMBLY | 15 |
| 8.2 ATTACH STAND TO TABLE SAW | 15 |
| TABLE SAW Stock No.82108 | |
| 8.3 ATTACH THE RIVING KNIFE | 16 |
| 8.4 ATTACH BLADE GUARD | 17 |
| 8.5 ATTACH FRONT & BACK RAIL | 17 |
| 8.6 RIP FENCE | 18 |
| 8.7 DUST EXTRACTION | 19 |
| 8.8 ATTACH HOSE SUPPORT BRACKET | 19 |
| 8.9 ATTACH WHEEL HANDLE | 20 |
| EXTENSION TABLE Stock No.82112 | |
| 8.10 ATTACH R/H EXTENSION TABLE | 21 |
| SLIDING CARRIAGE Stock No.82109 | |
| 8.11 ATTACH CARRIAGE SUPPORT ARMS | 22 |
| 8.12 ATTACH THE SLIDING CARRIAGE | 22 |
| 8.13 SETTING UP SLIDING CARRIAGE | 22 |
| 8.14 ATTACH ANGLE FENCE | 23 |
| 8.15 LENGTH STOP | 23 |
| 9 SETTING UP THE TABLE SAW | |
| 9.1 RIP SCALE ALIGNMENT | 24 |
| 9.2 MITRE FENCE | 24 |
| 9.3 SLIDING CARRIAGE ANGLE FENCE 90° PRESET | 25 |
| 9.4 SETTING UP ANGLE CUT | 25 |
| 9.5 CHANGING THE BLADE HEIGHT | 26 |
| 9.6 CHANGING THE BLADE ANGLE (BEVEL ANGLE) | 26 |
| 9.7 BLADE ALIGNMENT | 27-28 |
| 10 BASIC TABLE SAW OPERATING | |
| 10.1 CUTTING METHODS | 29-31 |
| 11 MAINTENANCE | |
| 11.1 BLADE REPLACEMENT | 32 |
| 12 TROUBLESHOOTING | |
| 12.1 TROUBLESHOOTING | 33 |
| 13 EXPLANATION OF SYMBOLS | |
| 10.1 EXPLANATION OF SYMBOLS | 34 |
| 14 DISPOSAL | |
| 14.1 DISPOSAL | 35 |
| 15 GLOSSARY | |
| | 36 |
| DECLARATION OF CONFORMITY | ENCLOSED |

3. GUARANTEE

3.1 GUARANTEE

Draper tools have been carefully tested and inspected before shipment and are guaranteed to be free from defective materials and workmanship.

Should the tool develop a fault, please return the complete tool to your nearest distributor or contact Draper Tools Limited, Chandler's Ford, Eastleigh, Hampshire, SO53 1YF. England. Telephone Sales Desk: (023) 8049 4333 or Product Helpline (023) 8049 4344.

A proof of purchase must be provided with the tool.

If upon inspection it is found that the fault occurring is due to defective materials or workmanship, repairs will be carried out free of charge. This guarantee period covering parts/labour is 12 months from the date of purchase except where tools are hired out when the guarantee period is 90 days from the date of purchase. This guarantee does not apply to normal wear and tear, nor does it cover any damage caused by misuse, careless or unsafe handling, alterations, accidents, or repairs attempted or made by any personnel other than the authorised Draper warranty repair agent.

Note: If the tool is found not to be within the terms of warranty, repairs and carriage charges will be quoted and made accordingly.

This guarantee applies in lieu of any other guarantee expressed or implied and variations of its terms are not authorised.

Your Draper guarantee is not effective unless you can produce upon request a dated receipt or invoice to verify your proof of purchase within the guarantee period.

Please note that this guarantee is an additional benefit and does not affect your statutory rights.

Draper Tools Limited.

4. INTRODUCTION

4.1 SCOPE

The table saw described in this manual is designed to cut wood and wood derived materials. The work piece is manually fed on to the saw blade. Any other application is considered misuse.

4.2 SPECIFICATION

| | |
|---|------------------------------|
| Stock nos. | 82108, 82112, 82110, 82109 |
| Part nos. | CTS200A, ACTS3, ACTS2, ACTS1 |
| Motor: | |
| Rated voltage | 230V |
| Rated frequency | 50Hz |
| Rated input | 1100W |
| Revolutions per minute (no load) | 4700r/min |
| Maximum depth of cut | |
| at 90° | 60mm |
| at 45° | 40mm |
| Blade diameter | 200mm |
| Bore size | 30mm |
| Table size | 400 × 535mm |
| fully extended..... | 1000 × 535mm |
| Sound power level | 60.0dB(A) |
| Sound pressure level | 85.0B(A) |
| Weight (all 82108, 82112, 82110, 82109 net) | 72kg |

4.3 HANDLING & STORAGE

The environment will have a negative result on its operation if you are not careful. If the air is damp, components will rust. If the machine is unprotected from dust and debris; components will become clogged: And if not cleaned and maintained correctly or regularly the machine will not perform at its best.

*A-Weighed sound power level in accordance to 2000/14/EC

5. HEALTH & SAFETY INFORMATION

5.1 GENERAL SAFETY INSTRUCTIONS FOR POWER TOOL USE

When using any type of power tool there are steps that should be taken to make sure that you, as the user, remain safe.

Common sense and a respect for the tool will help reduce the risk of injury.

Read the instruction manual fully. Do not attempt any operation until you have read and understood this manual.

Most important you must know how to safely start and stop this machine, especially in an emergency.

Keep the work area tidy and clean. Attempting to clear clutter from around the machine during use will reduce your concentration. Mess on the floor creates a trip hazard. Any liquid spilt on the floor could result in you slipping.

Find a suitable location. If the machine is bench mounted; the location should provide good natural light or artificial lighting as a replacement. Avoid damp and dust locations as it will have a negative effect on the machine's performance. If the machine is portable; do not expose the tool to rain. In all cases do not operate power tools near any flammable materials.

Beware of electric shock. Avoid contact with earthed surfaces; because they can conduct electricity if there is an electrical fault with the power tool. Always protect the power cable and route it away from danger.

Keep bystanders away. Children, onlookers and passers by must be restricted from entering the work area for their own protection. The barrier must extend a suitable distance from the tool user.

Unplug and house all power tools that are not in use. A power tool should never be left unattended while connected to the power supply. They must be housed in a suitable location, away locked up and from children.

Do not overload or misuse the tool. All tools are designed for a purpose and are limited to what they are capable of doing. Do not attempt to use a power tool (or adapt it in any way) for an application it is not designed for. Select a tool appropriate for the size of the job. Overloading a tool will result in tool failure and user injury: This covers the use of accessories.

Dress properly. Loose clothing, long hair and jewellery are all dangerous because they can become entangled in moving machinery: This can also result in parts of body being pulled into the machine. Clothing should be close fitted, with any long hair tied back and jewellery and neck ties removed. Footwear must be fully enclosed and have a nonslip sole.

Wear personal protective equipment (PPE). Dust, noise, vibration and swarf can all be dangerous if not suitably protected against. If the work involving the power tool creates dust or fumes; wear a dust mask. Vibration to the hand, caused by operating some tools for longer periods must be protected against. Wear vibration reducing gloves and allow long breaks between uses. Protect against dust and swarf by wearing approved safety goggles or a face shield. These are some of the more common hazards and preventions; however, always find out what hazards are associated with the machine/work process and wear the most suitable protective equipment available.

Do not breathe contaminated air. If the work creates dust or fumes; connect the machine (if possible) to an extraction system either locally or remotely. Working outdoors can also help if possible.

Move the machine as instructed. If the machine is hand held, do not carry it by the power supply cable. If the product is heavy; employ a second or third person to help move it safely or use a mechanical device. Always refer to the instructions for the correct method.

Do not overreach. Extending your body too far can result in a loss of balance and you falling. This could be from a height or onto a machine and will result in injury.

Maintain your tools correctly. A well maintained tool will do the job safely. Replace any damaged or missing parts immediately with original parts from the manufacturer. As applicable; keep blades sharp; moving parts clean, oiled or greased; handles clean; and emergency devices working.

5. HEALTH & SAFETY INFORMATION

Wait for the machine to stop. Unless the machine is fitted with a safety brake; some parts may continue to move due to momentum. Wait for all parts to stop; then unplug it from the power supply before making any adjustments, carrying out maintenance operations or just finishing using the tool.

Remove and check setting tools. Some machinery requires the use of additional tools or keys to set, load or adjust the power tool. Before starting the power tool always check to make certain they have been removed and are safely away from the machine.

Prevent unintentional starting. Before plugging any machine in to the power supply, make sure the switch is in the OFF position. If the machine is portable; do not hold the machine near the switch and take care when putting the machine down; that nothing can operate the switch.

Carefully select an extension lead. Some machines are not suitable for use with extension leads. If the tool is designed for use outdoors; use an extension lead also suitable for that environment. When using an extended lead, select one capable of handling the current (amps) drawn by the machine in use. Fully extend the lead regardless of the distance between the power supply and the tool. Excess current (amps) and a coiled extension lead will both cause the cable to heat up and can result in fire.

Concentrate and stay alert. Distractions are likely to cause an accident. Never operate a power tool if you are under the influence of drugs (prescription or otherwise), including alcohol or if you are feeling tired. Being disorientated will result in an accident.

Have this tool repaired by a qualified person. This tool is designed to confirm to the relevant international and local standards and as such should be maintained and repaired by someone qualified; using only original parts supplied by the manufacturer: This will ensure the tool remains safe to use.

5.2 SPECIFIC SAFETY INSTRUCTIONS FOR TABLE SAWS

WARNING

For your own safety, do not operate your saw until it is completely assembled and installed according to the instructions....and until you have read and understood the safety rules, assembly procedures, adjustment procedures and maintenance etc.

1. STABILITY.

There may be a tendency for the saw to tip over or move during certain cutting operations, such as, cutting extremely large heavy panels or long heavy boards, so the saw must be bolted down.

2. MINIMISE POTENTIAL ACCIDENTS.

Most accidents are caused by **FAILURE TO FOLLOW SET UP AND OPERATION INSTRUCTIONS**. Avoid awkward hand positions, where a sudden slip could cause a hand to move into a saw blade or other cutting tool. Never reach behind, or around the blade with the hand holding down the workpiece for any reason.

DO NOT PLACE FINGERS OR HANDS IN THE PATH OF THE SAW BLADE.

3. Never reach under your machine when operating or make any adjustments when it is running.
4. Turn the saw 'OFF' and disconnect the power supply when changing the blade, removing or replacing the blade guard, or making any adjustments.
5. Always maintain control of the workpiece. **DO NOT 'LET GO'** of the workpiece until the machine has stopped.
6. When removing short workpieces, or cleaning up around the table, be sure the saw is switched 'OFF'.
7. Never turn the saw 'ON' before clearing the table of all tools, wood scraps, etc., except the workpiece and related feed or support devices for the operation.
8. When moving the saw, disconnect power supply.

5. HEALTH & SAFETY INFORMATION

9. Never hold onto or touch the 'free end' of the workpiece or a 'free piece' that is cut off, while power is 'ON' and/or the saw blade is rotating.
10. If you stall or jam the saw blade in the workpiece, turn power 'OFF', remove the workpiece from the saw blade and check to see if the saw blade is parallel to the table slots or grooves and if the riving knife is in alignment with the saw blade. If ripping at the time, check to see if the rip fence is parallel with the saw blade. Adjust as indicated in this manual.
WARNING: Do not allow familiarity (gained from frequent use of your saw) to become commonplace. Always remember that a careless fraction of a second is sufficient to inflict severe injury.
11. **MAKE SURE YOUR FINGERS DO NOT CONTACT THE TERMINALS OF THE POWER PLUG** when installing or removing from the mains power supply.
12. **KICKBACKS - THEIR CAUSE.**
Kickbacks can cause serious injury. A kickback occurs when a part of the workpiece binds between the saw blade and the rip fence or another object rises from the table and is thrown towards the operator. Kickbacks can be avoided by attention to the following conditions:
13. **KICKBACK - HOW TO AVOID THEM AND PROTECT YOURSELF FROM POSSIBLE INJURY.**
 - a) Be certain that the saw blade is parallel to the rip fence.
 - b) Do not rip by applying the feed force to the section of the workpiece that will become the cut-off (free) piece. Feed force when ripping should always be applied between the saw blade and the fence...use a push-stick for short work or less than 6" wide.
 - c) Keep saw blade guard and riving knife in place and operating properly. The riving knife must be in alignment with the saw blade.
14. Do not leave a long board (or other workpiece) unsupported so the spring of the board causes it to shift on the table. Provide proper support for the workpiece, based on its size and the type of operation to be performed. Hold the work firmly against the fence and down against the table surface.
15. Never use a length stop on the free end of the workpiece when cross cutting. Never hold onto or touch the free end of the workpiece when cross cutting, or a free piece that is cut off when ripping while power is 'ON' and/or the saw blade is rotating. In short, the cut-off piece in any 'through-sawing' (cutting completely through the workpiece) operation must never be confined – it must be allowed to move laterally.
16. **IF YOUR SAW MAKES AN UNFAMILIAR NOISE OR IF IT VIBRATES EXCESSIVELY, CEASE OPERATING IMMEDIATELY UNTIL THE SOURCE HAS BEEN LOCATED AND THE PROBLEM CORRECTED.**
17. **EXTENSION LEADS**
The use of any extension lead will cause some loss of power. Use only extension leads which have a 3-pin plug and 3-pin sockets which accept the tools plug.
18. **SAFETY PRECAUTIONS**
 - Do not use saw blades which are damaged or deformed;
 - Replace table insert when worn;
 - Use only saw blades recommended by the manufacturer, which conform to EN 847-1.
 - **WARNING:** Ensure that the dimensions of the replacement blade are equal to the one you are replacing, i.e. bore size, diameter and thickness.
 - Take care that the selection of the saw blade is suitable for the material to be cut;
 - Wear suitable personal protective equipment when necessary, which should include:
 - hearing protection to reduce the risk of induced hearing loss,
 - respiratory protection to reduce the risk of inhalation of harmful dust,
 - gloves when handling saw blades and rough material. Saw blades shall be carried in a holder whenever practicable.
 - eye protection to reduce risk of particles entering eyes.

5. HEALTH & SAFETY INFORMATION

- Connect circular saws to a dust-collecting device when sawing.
- Do not use High speed steel (HSS) blades;
- The push-stick or push block should always be stored with the machine when not in use.

19. SAFE OPERATION

- Use push-sticks or push blocks to feed the workpiece past the saw blade;
- Use and correct adjustment of the riving knife;
- Use and correct adjustment of the upper saw blade guard;
- Rebating or grooving should not be carried out.
- Saws shall not be used for slotting (stopping groove);
- Use only saw blades for which the maximum possible speed is not less than the maximum spindle speed of the tool and the material to be cut;
- When transporting the machine use only transportation devices and do not use guards for handling or transportation;
- During transportation the saw blade should be lowered below the table height.

5.3 CONNECTION TO THE POWER SUPPLY

Make sure the power supply information on the machine's rating plate are compatible with the power supply you intend to connect it to.

If a replacement plug is to be fitted this must be carried out by a qualified electrician.

The damaged or incomplete plug, when cut from the cable shall be disabled to prevent connection to a live electrical outlet.

This appliance is Class I[†] and is designed for connection to a power supply matching that detailed on the rating label and compatible with the plug fitted.

If an extension lead is required, use an approved and compatible lead rated for this appliance. Follow all the instruction supplied with the extension lead.

[†]Earthed : This product requires an earth connection to protect against electric shock from accessible conductive parts in the event of a failure of the basic insulation.

6. TECHNICAL DESCRIPTION

6.1 IDENTIFICATION

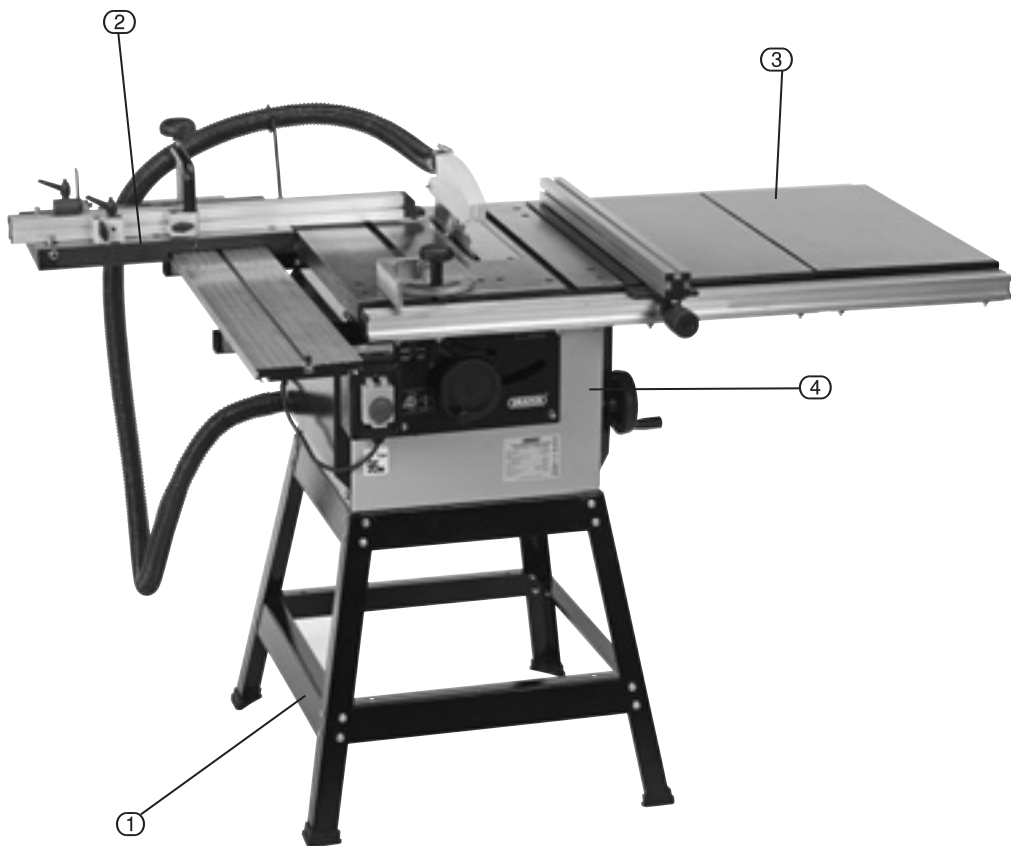

- ① Stand kit (Stock No.82110)
- ② Sliding carriage (Stock No.82109)

- ③ Right side extension table (Stock No.82112)
- ④ Table saw (Stock No.82108)

7. UNPACKING & CHECKING

7.1 PACKAGING

Carefully remove the product from the packaging and examine it for any sign of damage that may have happened during shipping. Lay the contents out and check them against the parts shown below. If any part is damaged or missing; please contact the Draper Helpline (the telephone number appears on the Title page) and do not attempt to use the product.

The packaging material should be retained at least during the guarantee period: in case the machine needs to be returned for repair.

Warning! Some of the packaging materials used may be harmful to children. Do not leave any of these materials within their reach.

If any of the packaging is to be thrown away, make sure they are disposed of correctly; according to local regulations.

7. UNPACKING & CHECKING

7.2 WHAT'S IN THE BOX?

Basic Table Saw Stock No.82108

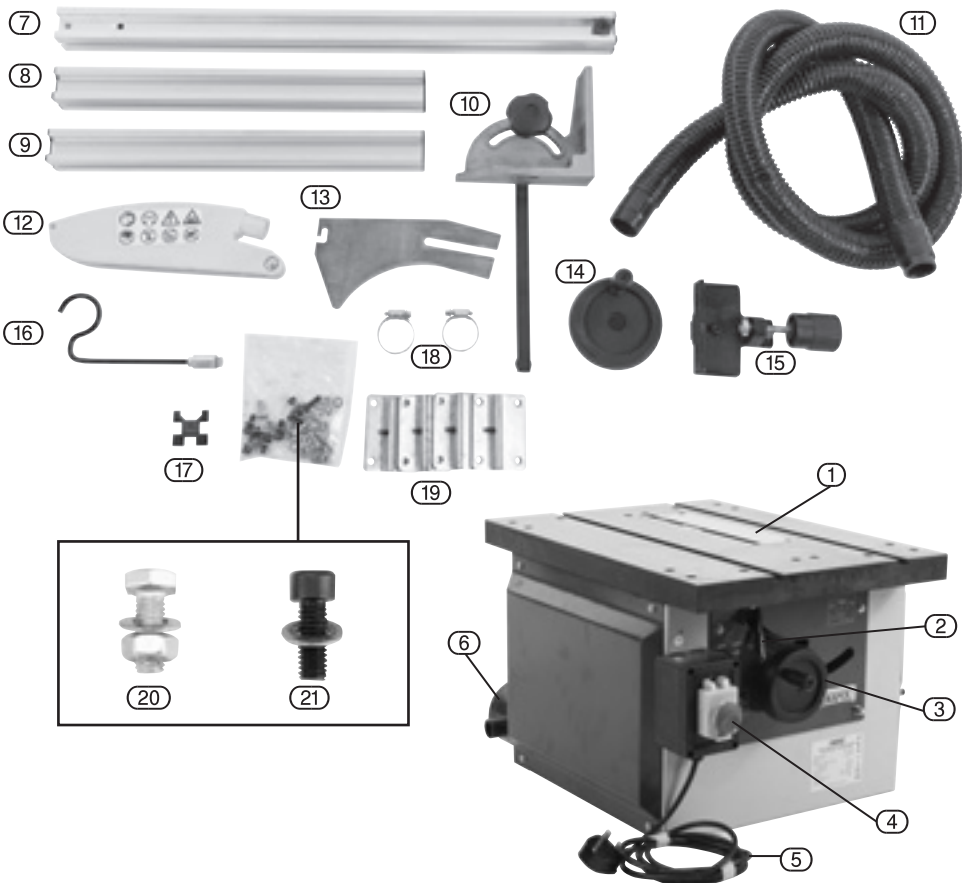

- ① Table insert.
- ② Blade angle lock.
- ③ Blade height adjustment wheel.
- ④ No-volt On/off switch.
- ⑤ Power cable and plug.
- ⑥ Dust Extraction moulding.

- ⑦ Rip fence rail.
- ⑧ Front rail with scale .
- ⑨ Back rail.
- ⑩ Mitre gauge.
- ⑪ Dust extraction flexible hose.
- ⑫ Blade guard.
- ⑬ Riving knife.
- ⑭ Blade angle adjustment wheel.
- ⑮ Rip fence clamp assembly.
- ⑯ Hose support bracket.
- ⑰ Rip fence end plastic cap.
- ⑱ 2x Hose clips.
- ⑲ 4x Rail support brackets.
- ⑳ 12x M10 x 20mm bolt, nut and washer.
- ㉑ 8x 5mm hex. M10 x 20mm bolt.

7. UNPACKING & CHECKING

Stand Kit Stock No.82110

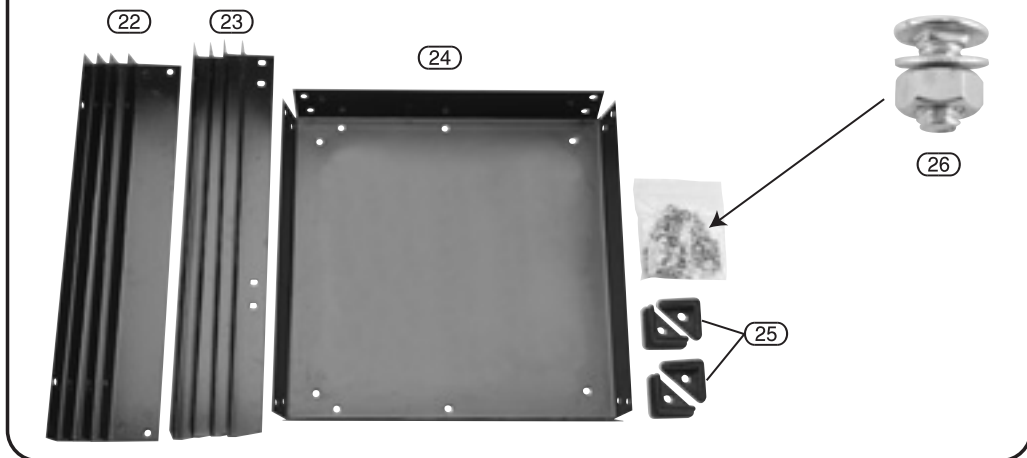

(22) 4x side struts.

(23) 4x legs.

(24) Top

(25) 4x Rubber feet.

(26) 32x M10 x 15mm bolt, nuts and washers.

Right Side Extension Table Kit Stock No.82112

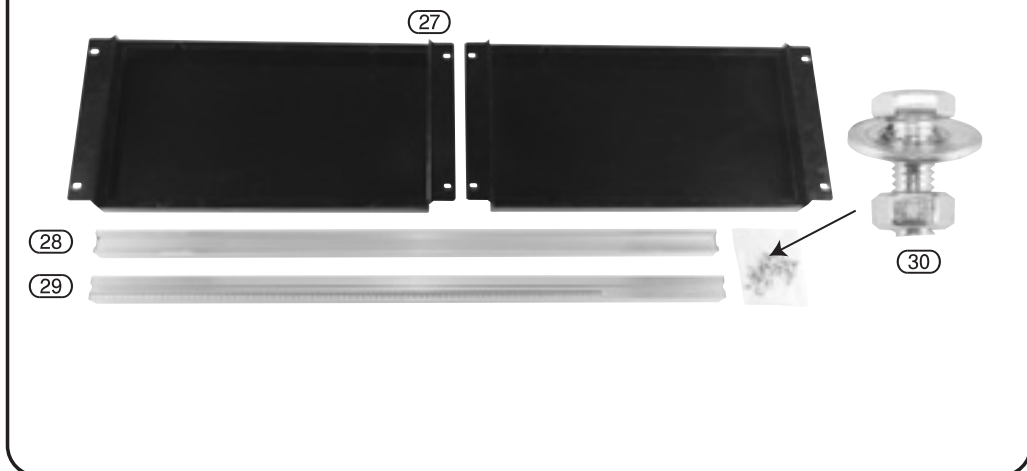

(27) Extension leaves.

(28) Rip back fence rail.

(29) Rip front fence rail with scale.

(30) 8x M10 x 20mm bolt, nut and washer.

7. UNPACKING & CHECKING

Sliding Carriage Stock No.82109

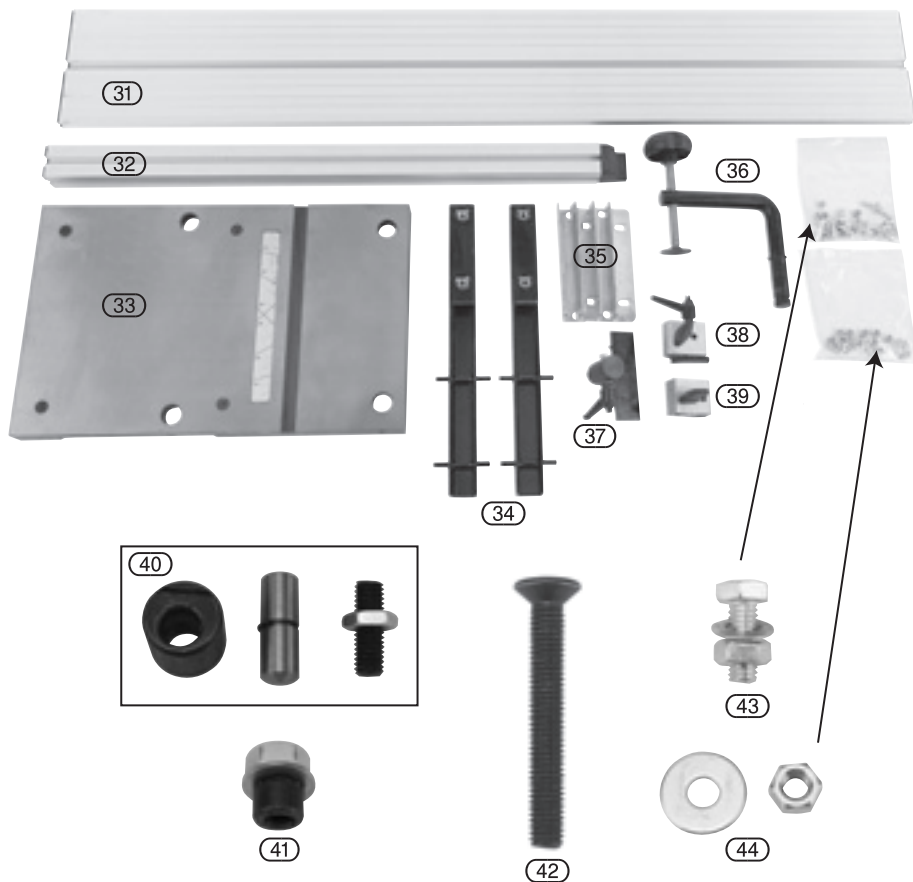

- (31) Carriage arm.
- (32) Angle fence.
- (33) Sliding carriage table.
- (34) 2x Sliding carriage support arms.
- (35) 4x Support arm bracket.
- (36) Work clamp assembly.
- (37) Work piece length stop.
- (38) Work clamp block.
- (39) Connecting block.
- (40) 2x Eccentric bush, pivot and grub screw.
- (41) 2x Sliding carriage end stops (6mm hex. M13 x 15mm).
- (42) 4x 5mm hex. M10 x 45mm countersunk head bolt.
- (43) 8x M10 x 15mm bolt, nut and washer.
- (44) 8x M10 nut and washer.

8. PREPARING THE TABLE SAW

STAND KIT Stock No.82110

8.1 STAND ASSEMBLY - FIGS. 1 & 2

Firstly lay all the lengths out on the floor, sorting the legs from the cross-struts.

With the top (24) of the stand on the ground upside down attach the legs (23), then attach the cross members (22) between the legs all with the 32x M10 bolts, washers and nuts (26) provided.

When the stand is complete attach the four rubber feet (25).

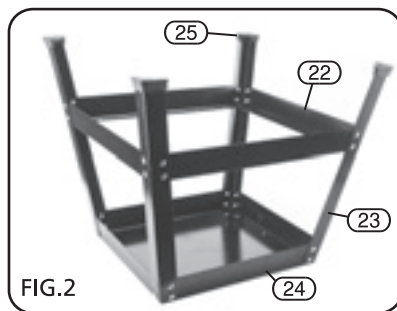
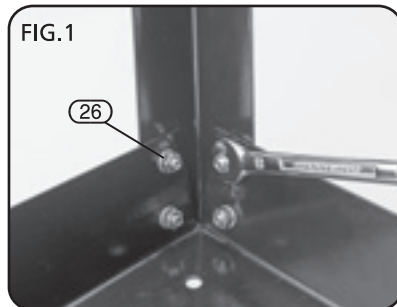

8.2 ATTACH STAND TO TABLE SAW - FIGS. 3 & 4

Place the table saw stand on top of the stand, remove a side panel to gain access to the inside of the table saw. Align the holes and secure in place with M10 bolts, nuts and washers (20).

IMPORTANT: If the saw is to be a permanent fixture, ensure it is sited in an area with adequate illumination and power supply.

DO NOT place it where you will be working in your own shadow, or where extension cables are required - these are hazardous in a workshop environment.

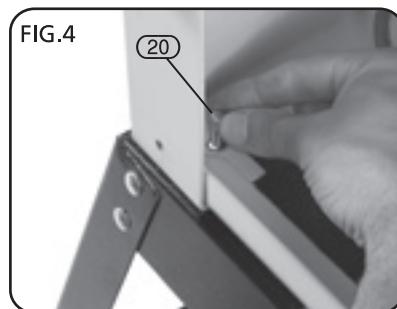

8. PREPARING THE TABLE SAW

TABLE SAW Stock No.82108

8.3 ATTACH THE RIVING KNIFE- FIGS. 5 - 7

Remove the table insert with a 4mm hex. key, then raise the blade to maximum height and blade angle to maximum to make access easier. Loosen the two nuts on the riving knife clamp with a 13mm spanner.

Slide the riving knife into place, adjust position so there is a clearance of approximately 5mm to the blade.

Then replace the table insert plate.

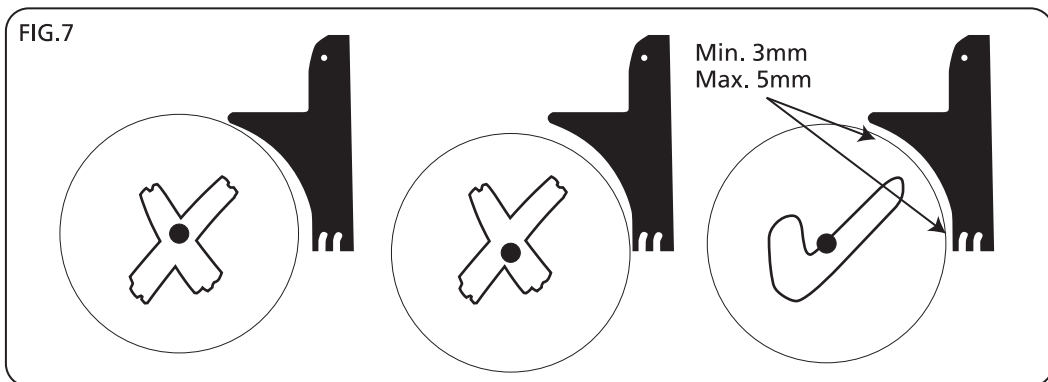

8. PREPARING THE TABLE SAW

8.4 ATTACH BLADE GUARD- FIGS. 8 & 9

To attach the blade guard (12) to the riving knife loosen the lock nut with a 10mm socket, slide guard into slot on top of the riving knife and tighten nut .

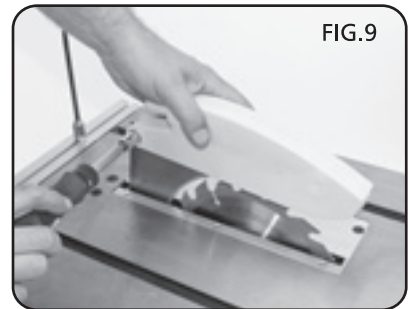
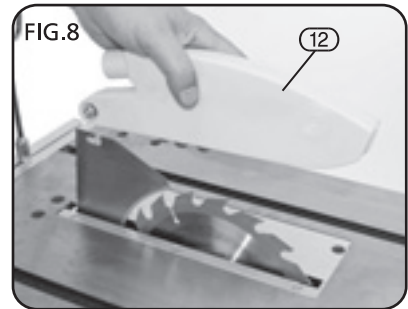

8.5 ATTACH FRONT & BACK RAIL - FIG. 10 & 11

Rail brackets (19) need to be bolted to the underside of the cast iron top along the front edge with hex. bolts (21).

Attach the nuts, bolts and washers (20) to the brackets loosely, then offer up the front rail (with rule on top) so the bolt heads slide along the 'T' slot on the under side.

The same method is used to attach the back rail.

When both rails have been lined up in there final position the nuts (20) and grub screws (19.1) need to be tightened (3mm hex.).

Note: If the extension table is brought as a separate unit (Stock No. 82112) then the short front & back rails will need to be replaced with the long rails supplied with the extension kit.

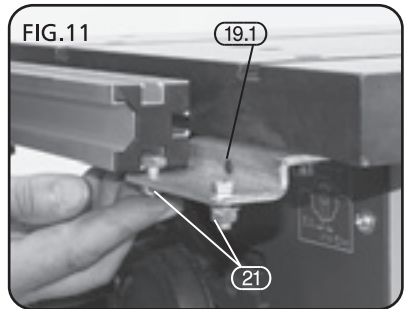
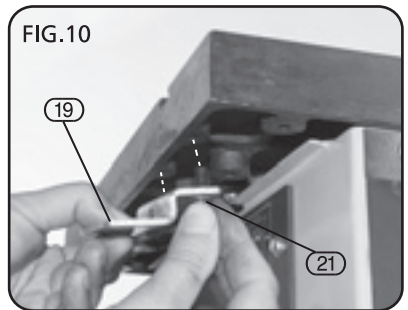

8. PREPARING THE TABLE SAW

8.6 RIP FENCE - FIGS. 12 - 16

The rip fence needs to be assembled.

The clamp (15) needs to be attached to the end of the rip fence.

Detach the bar (15.1) from the clamp assembly and slide it into the end of the rip fence (7). Bolt the clamp to the bar through the fence with assembly fixings.

Unwind the clamp and slide onto the open end of front rail.

CAUTION: The rip fence must be parallel to the blade to minimise the danger of kick back.

Note: If not parallel see section blade alignment page in the setting the table saw section page 25.

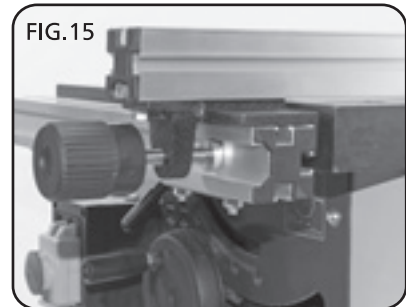
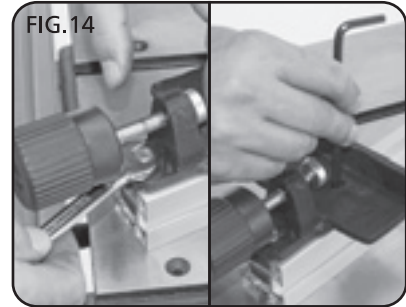
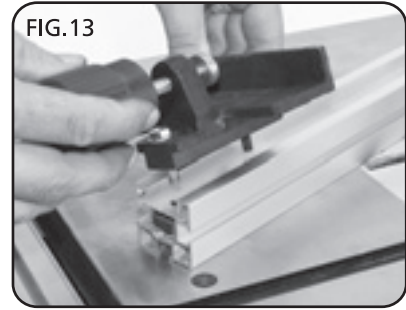
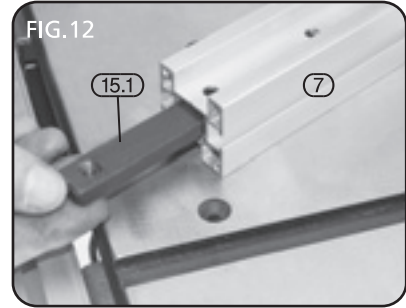

8. PREPARING THE TABLE SAW

To protect the use from a cutting hazard there are plastic end caps attached to the ends of the aluminium extrusions. The rip fence plastic cap needs to be fixed after the rip fence has been assembled (17).

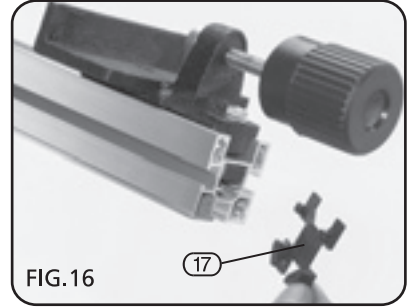

8.7 DUST EXTRACTION – FIGS. 17 - 18

Fit the dust extraction hose (9) onto the blade guard (12) using one of the hose clamps (18) supplied.

Inhalation of dust particles can be detrimental to health. The dust outlet (6) **must** be connected with a dust extraction machine.

Note: Due to the outlet diameter, a size adaptation may be necessary.

All wood dust (including dust from composites like chipboards and fibre boards etc) is hazardous to health; it can affect the nose, the respiratory system and the skin. For example MDF (medium density fibreboard) which contains formaldehyde is a known carcinogen. In addition to the above measures a correctly fitted dust mask, suitable for the activity and in accordance to the relevant standard, must be worn. For work activities involving exposure to fine wood dust a mask rated to at least FFP2 should be used.

Machine is fitted with 100mm dust extraction outlet.

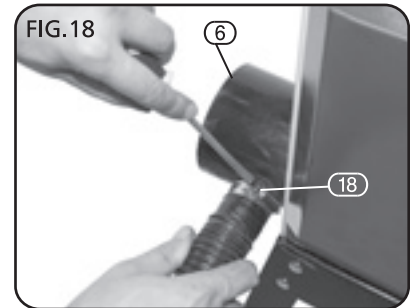
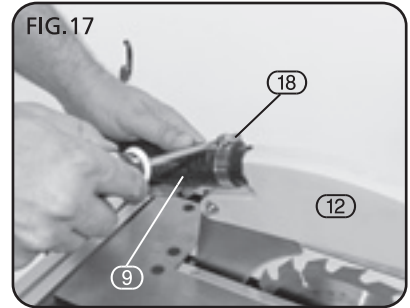

8.8 ATTACH HOSE SUPPORT BRACKET - FIG. 19

The bracket (16) is attached to the top of the back rail. Insert bolt head into slot and slide along rail to best position, (holding the extraction hose up out of the way of the work piece). The base of the bracket is hexagonal (16.1) in design so can be tightened using a 14mm spanner, the 10mm locknut (16.2) locks the angle of bracket.

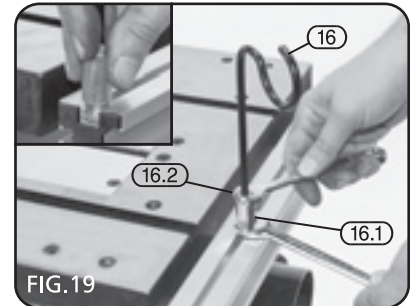

8. PREPARING THE TABLE SAW

8.9 ATTACH BLADE ANGLE ADJUSTMENT WHEEL- FIG. 20

Unwind the grub screw (14.1).

Align the grub screw with the flat on the shaft (14.2) of the tilt mechanism and slide the wheel handle on.

Tighten the grub screw.

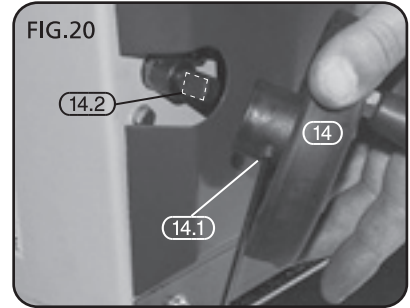

8. PREPARING THE TABLE SAW

R/H EXTENSION TABLE Stock No.82112

8.10 ATTACH R/H EXTENSION TABLE - FIGS. 21 - 23

Note: If the extension table is brought as a separate unit (Stock No. 82112) then the short front & back rails will need to be replaced with the long rails supplied with the extension kit (see fig.11).

With both front and back rails attached, the two part extension leaves can be added in between.

The nuts, bolts and washers are added to the leaves. The heads to the bolts are to slid into the 'T' slot on the under side of the front and back rails.

When all in position tighten all fixtures.

Reattach hose support bracket as 8.8.

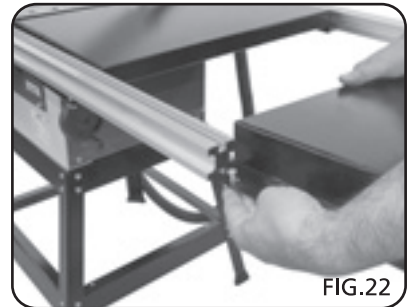

8. PREPARING THE TABLE SAW

SLIDING CARRIAGE Stock No.82109

8.11 ATTACH CARRIAGE SUPPORT ARMS - FIGS. 24 & 25

There are two support arms (34) that need to be attached to the cast iron table top, the bolts (42) are fed through the table top into the support arms. Attach two brackets (35) per support arm using nuts and washers (44).

Note: The brackets are attached to the support arms through slots (35.1) so that the height of the sliding carriage can be adjusted.

Nuts, bolts and washers (43) are loosely attached to the brackets with the bolt head on top. Feed the bolt heads into the under side of the carriage rail (31) to slide into the 'T' slots up to the finished position, then tighten all fixings.

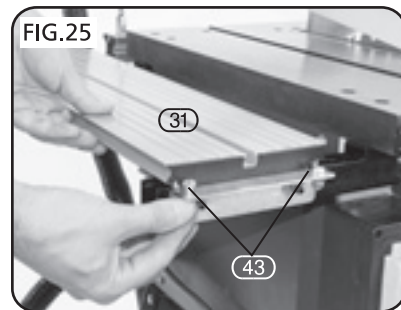
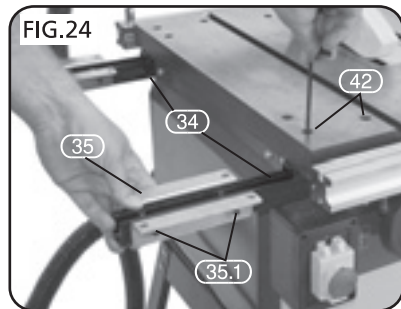

8.12 ATTACH THE SLIDING CARRIAGE - FIG. 5

When the sliding carriage (33) has been fed onto the rail, slide it to the centre; then the end stops (41) can be attached at the front and the back of the rail.

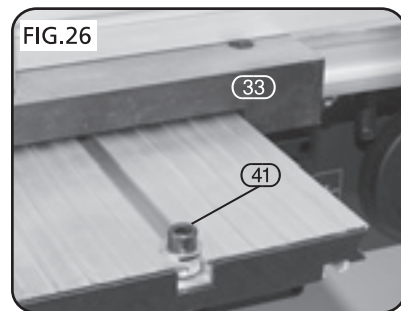

8.13 SETTING UP SLIDING CARRIAGE - FIG. 7

The connecting block (38) slides into the groove on the sliding carriage.

The work clamp (36) slides through the work clamp block (39) into the hole on the sliding carriage, then fastened in place with a grub screw on the front edge.

Note: The angle fence can be setup at front or back of the sliding carriage, depending on whether you prefer to hold work piece in front or behind the fence.

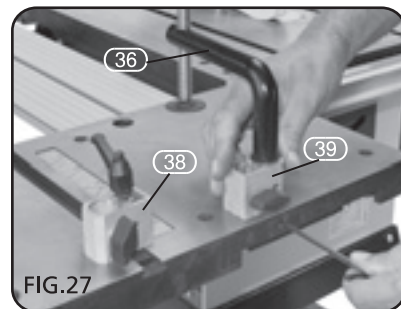

8. PREPARING THE TABLE SAW

8.14 ATTACH ANGLE FENCE - FIG. 28

Slide both the work clamp block and the connecting block onto the angle fence.

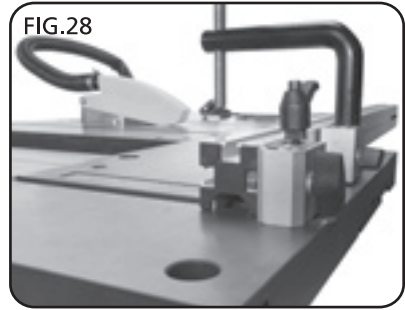

8.15 LENGTH STOP - FIG. 29

A length stop is connected to the angle fence, with a bolt head sliding in the top 'T' slot. It can slide along the total length and can be attached either side of the fence.

Used mainly when the same length cut is needed in repetition.

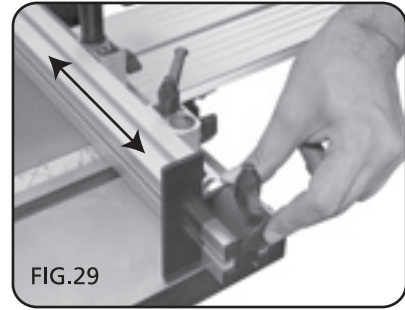

9. SETTING UP THE TABLE SAW

9.1 RIP SCALE ALIGNMENT- FIG. 30

Once the rip fence has been assembled then it can be used to line up the scale rule '0' on the front rail with the blade. If the rule does not line up, then the rail needs to be loosened from the bracket and moved to match (see fig. 11).

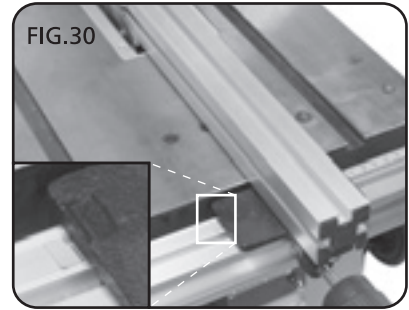

9.2 MITRE GAUGE - FIGS. 31 & 32

The mitre gauge (10) is suitable for most applications but for extra accuracy, a protractor or other measuring device should be used when setting the cutting angle. Test the accuracy of the angle on a piece of scrap material before cutting the work piece:

- When using the left hand groove, hold the work piece firmly against the mitre gauge head with your left hand, and push with your right hand.
- When using the right hand groove, hold the work piece with the right hand and push with the left.

WARNING: THE RIP FENCE MUST BE REMOVED FROM THE TABLE WHEN USING THE MITRE GAUGE.

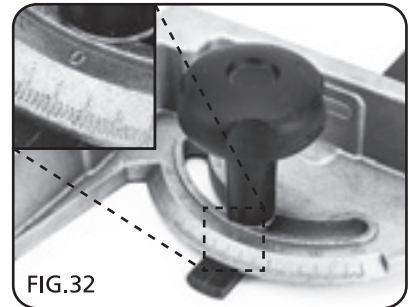
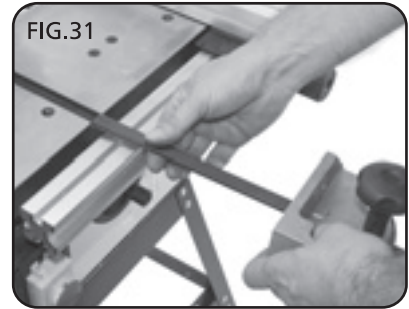

9. SETTING UP THE TABLE SAW

9.3 SLIDING CARRIAGE ANGLE FENCE 90° PRESET - FIG. 33

The angle fence stop (40.1) allows 90° to be setup as a preset.

To set accurately a square is placed against the blade and the fence, then amend the preset pin position to match. The eccentric bush holding the pin can be adjusted by releasing the grub screw to the side of the sliding carriage table, then inserting a plain slot screwdriver into the slot and turn so the stop moves the fence to 90°.

Note: At the back of the carriage table there is a duplicate set of holes; this allows the user to place work piece the opposite side of the angle fence.

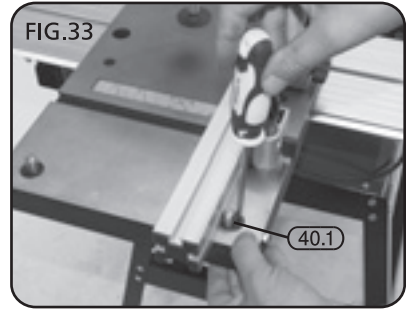

9.4 SETTING UP ANGLE CUT - FIG. 34

To set an angle between 45° and 90° loosen the three locking points (38.1) on the two blocks. Line the fence up with the angle gauge on the sliding carriage.

Note: As with the mitre gauge the gauge fixed on the sliding carriage is suitable for most applications but for extra accuracy, a protractor or other measuring device should be used when setting the cutting angle. Test the accuracy of the angle on a piece of scrap material before cutting the work piece:

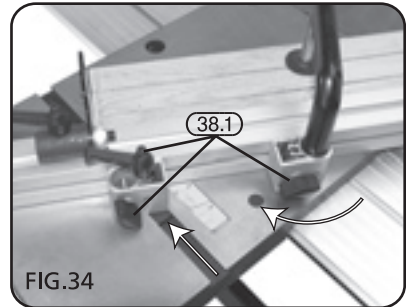

9. SETTING THE TABLE SAW

9.5 CHANGING THE BLADE HEIGHT – FIGS. 35 - 36

Adjust the cut height with the hand wheel (3).

Select the cutting height so that the saw blade teeth still protrude from the work piece to be processed.

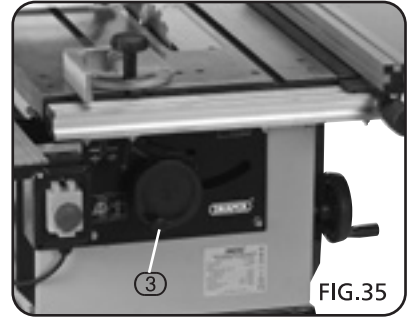

CAUTION: The saw blade must be set approximately 5mm above the work piece top. Any greater exposure of the saw blade increases the risk of kick back.

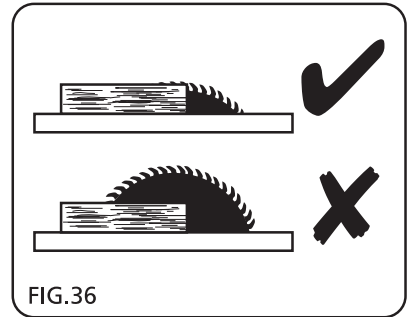

9.6 CHANGING THE BLADE ANGLE (BEVEL ANGLE) – FIGS. 37 - 38

Release the locking lever (2). The saw blade can now be adjusted (from 90° to 45°) using wheel (14). Once the correct angle is achieved lock in place with locking lever (2), the blade height can then be adjusted to make cut safe.

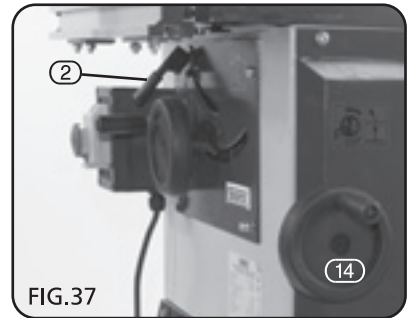

There is an adjusting screw on the angle pointer (14.1) this can be adjusted to make angle more accurate.

Note: The angles are an estimate, for a true angle to be achieved then a piece of spare wood needs to be cut and measured, any fine adjustments can be made until correct angle is achieved.

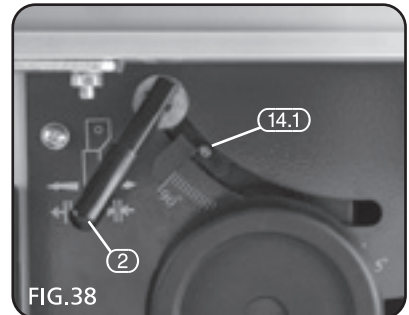

9. SETTING THE TABLE SAW

9.7 BLADE ALIGNMENT - FIGS. 39 - 43

If the blade is not cutting straight, the blade is out of alignment. Follow the instructions below to set the blade to the table.

Note: You will require a 4mm Hex key and a steel rule

1. Remove the blade guard (12) and table insert (1).

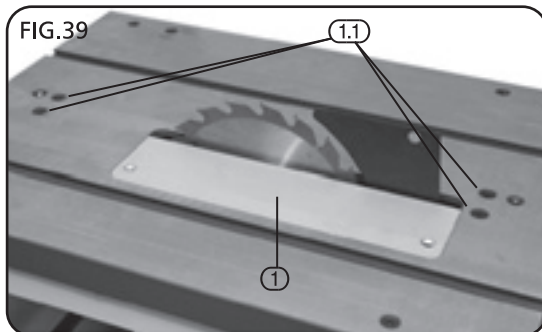

2. Loosen the four Hex screws (1.1).

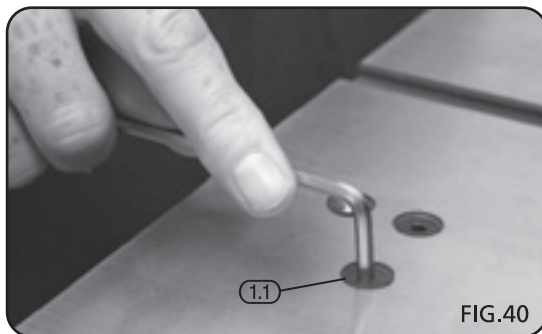

3. Place the steel rule up-against one end of the blade and take a measurement to the 'T' slots edge.

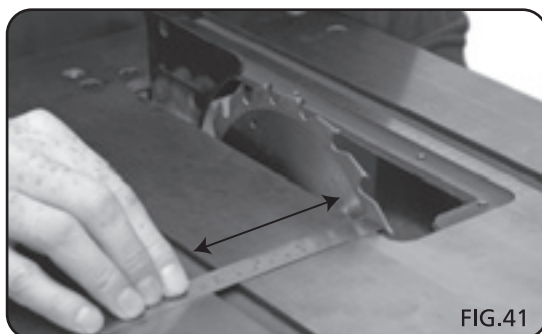

9. SETTING THE TABLE SAW

- Place the rule to the opposite end of the blade and take a further reading.

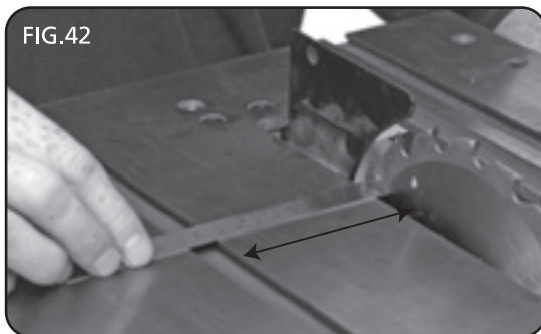

- If there is any deviations between the measurements, adjust the blade assembly (A) by moving each end on it's rails (B), until both ends of the blade are the same distance away from the 'T' slot edge.

Remove side panel from table saw to access the blade assembly.

- Tighten the four Hex. screws.
- Replace the blade guard and table insert.

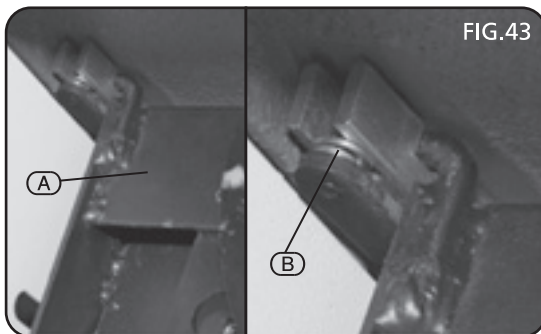

10. BASIC TABLE SAW OPERATION

10.1 CUTTING METHODS – FIGS. 44 - 49

RIPPING:

- Secure the rip fence to the table.
- Remove the mitre guide.
- Raise the blade to 5mm higher than the top of the work piece.
- Hold the work piece flat on the table and against the fence. Keep the work piece about 25mm back from the blade.

CAUTION: The work piece must have a straight edge against the fence and must not be warped, twisted or bowed in any way.

- Keep both hands away from the blade and away from the path of the blade.
- Turn the saw on and allow the blade to reach full speed.
- Keeping the work piece against the table and fence, slowly feed the work piece towards the saw blade.
- Stand with your body to one side of the blade and at the front of the table when feeding the wood. This will reduce the risk of injury should a piece of wood kickback or kick up.
- Continue pushing the work piece until it is clear of the guard and it falls off the rear of the table. Do not overload the motor. Never try to pull a work piece back with the blade turning. Turn the switch off, allow the blade to stop and slide the work piece out.

RIPPING SMALL/FLAT PIECES OF WOOD:

- This is an unsafe practice and not recommended. It is not safe to have your hands close to the blade. Instead, rip a large piece of material to obtain the desired size.
- When a small piece requires ripping use a push stick to hold the work piece in place, keeping your hands away from the blade.

BEVEL RIPPING:

- This operation is the same as ripping except that the blade angle is set to an angle greater than 0°.

Warning: Only operate with the work piece and rip fence on the right side of the blade to reduce the risk of kickback.

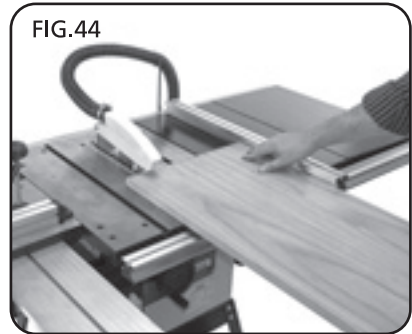

10. BASIC TABLE SAW OPERATION

WORK PIECE SUPPORT:

- Longer pieces need extra supports, for example, a roller stand (A) (Draper stock No.13886 or 13887). The supports should be placed to the side for wider material or to the rear for longer material so the work piece does not sag or kick up.
- The support should allow the work piece to lay flat on the table during the cutting operation.

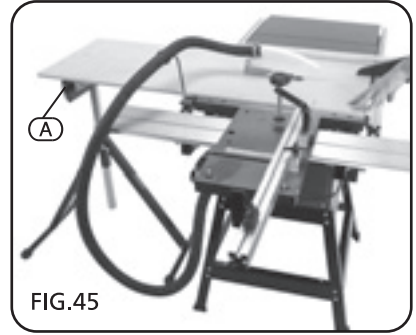

FIG.45

CROSS CUTTING:

Using a mitre guide

- Remove the rip fence and place the mitre guide in the table slot.

Using a sliding carriage (Stock No.82109).

- Turn the angle fence to 90° to the blade, this should be easy using the angle fence stop.
- Set the blade height 5mm above the work piece top.
- Hold the work piece firmly against the mitre guide with both hands.
- Start the saw and allow the blade to spin up to full speed. Whilst gripping the work piece firmly against the guide and pushing flat against the table, slowly slide the wood through the blade.



FIG.46

BEVEL CROSS CUTTING:

- This operation is the same as cross cutting except that the blade angle is set to an angle greater than 0°.



FIG.47

10. BASIC TABLE SAW OPERATION

MITRE CUTTING:

There are two methods available to cut a mitre.

- This operation is the same as cross cutting except the mitre guide is set at any angle other than 90°. Firstly remove the rip fence and any other obstacles in the way, keep area clean.

- (i) Sliding the small mitre gauge in the grooves on the table top either side of the blade.

Note:

- When using the left hand groove, hold the work piece firmly against the mitre gauge head with your left hand, and push with your right hand.
- When using the right hand groove, hold the work piece with the right hand and push with the left.

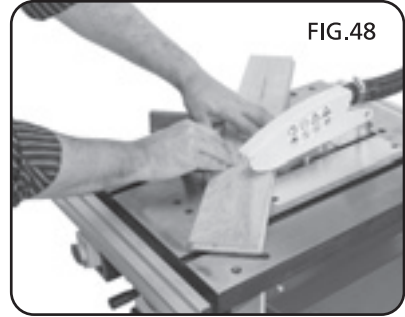

- (ii) Using the sliding carriage (Stock No. 82109 see 8.8 for setting angles). This operation is the same as cross cutting except the mitre guide is set at any angle other than 90° set the angle using the angle guide on the carriage table.

Note: As with the bevel angle the mitre cut angles are an estimate, for a true angle to be achieved then a piece of spare wood needs to be cut and measured, any fine adjustments can be made until correct angle is achieved.

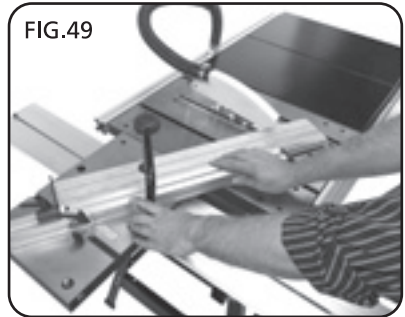

COMPOUND MITRE CUTTING:

- This is a combination of bevel cross cutting and mitre cutting. It is very infrequently used.
- Follow the instructions for both mitre cutting and bevel cross cutting.

11. MAINTENANCE

11.1 BLADE REPLACEMENT - FIGS. 50 - 51

Note: Remove the plug from the socket before carrying out adjustment, servicing or maintenance. Raise the saw blade to its highest point, remove the saw blade guard, remove the four Hex screws that secure the table insert, place carefully aside and remove the table insert.

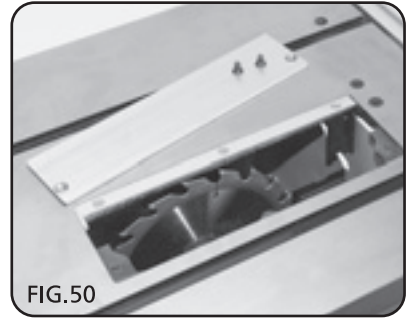

Put a spanner onto the flats on the bolt and place a piece of timber up against the saw blade to stop it from moving.

Slacken off the saw bolt (remember right hand thread). Remove the saw bolt, then remove the saw plate washer and the saw blade. It would be a good time to give the interior of the machine, the dust extraction channels, etc. a thorough clean.

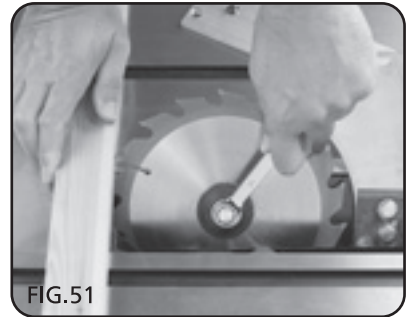

Check the new blade for damage, missing teeth, sharpness etc. Fit the new blade, ensure that the teeth are pointing towards the front of the machine. Put the saw plate washer onto the shaft and twist on the saw bolt. Spin the bolt up finger tight and check the saw is correctly seated.

Place the piece of timber against the blade as before and tighten up the saw bolt, check the riving knife is aligned with the saw blade, and correctly positioned. Replace the table insert and secure with the four Hex. screws. Replace the saw blade guard. When everything is satisfactory, turn the saw blade once by hand to check it doesn't foul anywhere.

Reconnect the machine to the mains supply. Give the machine a 'quick' burst check (i.e. quick ON-OFF) to ensure everything is O.K. If everything is satisfactory, continue to use the machine.

12. TROUBLESHOOTING

12.1 TROUBLESHOOTING

WARNING: For your own safety, turn the switch off and remove the plug from the power supply socket.

| Trouble | Probable Cause | Remedy |
|--|--|--|
| Saw will not start. | <ol style="list-style-type: none"> 1. Saw not plugged in. 2. Fuse blown or circuit breaker tripped. 3. Cable damaged. | <ol style="list-style-type: none"> 1. Plug in saw. 2. Replace fuse or reset circuit breaker. 3. Have cable replaced. |
| Does not make accurate 45° and 90° rip cuts. | <ol style="list-style-type: none"> 1. Tilt angle pointer not set accurately. | <ol style="list-style-type: none"> 1. Check blade with square and adjust pointer to zero. |
| Material pinches blade when ripping. | <ol style="list-style-type: none"> 1. Rip fence not aligned with blade. 2. Warped wood, edge against fence not straight. | <ol style="list-style-type: none"> 1. Check and adjust rip fence. 2. Select another piece of wood. |
| Material binds on riving knife. | <ol style="list-style-type: none"> 1. Riving knife not aligned correctly with blade. | <ol style="list-style-type: none"> 1. Check and align riving knife with blade. |
| Saw makes unsatisfactory Cuts | <ol style="list-style-type: none"> 1. Blunt blade. 2. Blade mounted backwards. 3. Gum or pitch on blade. 4. Incorrect blade for work piece. 5. Gum or pitch on table causing erratic feed. | <ol style="list-style-type: none"> 1. Re sharpen or replace blade. 2. Turn blade around. 3. Remove blade and clean with white spirit and coarse steel wool. 4. Change to correct type of blade. 5. Clean the table. |
| Material kicked back from blade | <ol style="list-style-type: none"> 1. Rip fence out of alignment. 2. Riving knife not aligned with blade. 3. Feeding work piece without rip fence. 4. Riving knife not in place. 5. Dull blade. 6. Letting go of material before it is past saw blade. 7. Blade angle locking knob not tight. | <ol style="list-style-type: none"> 1. Align rip fence with blade. 2. Align riving knife with the blade. 3. Install and use the rip fence. 4. Install and use riving knife (with guard). 5. Replace the blade. 6. Push material all the way past saw blade before releasing the work. 7. Tighten knob. |
| Blade does not raise or tilt freely. | <ol style="list-style-type: none"> 1. Sawdust and dirt in raising and tilting mechanism. | <ol style="list-style-type: none"> 1. Vacuum out loose dust and dirt. |
| Blade does not Run up to speed. | <ol style="list-style-type: none"> 1. Extension cable too light or too long. 2. Low mains voltage. | <ol style="list-style-type: none"> 1. Replace with adequate size extension cable. 2. Check supply voltage. |
| Machine vibrates excessively. | <ol style="list-style-type: none"> 1. Saw not mounted securely to stand or work bench. 2. Stand or bench on uneven floor. 3. Damaged saw blade. | <ol style="list-style-type: none"> 1. Tighten all fixings. 2. Reposition on flat level surface. Fasten to floor if necessary. 3. Replace blade. |
| Does not make accurate 45° and 90° cross cuts. | <ol style="list-style-type: none"> 1. Mitre gauge out of adjustment. | <ol style="list-style-type: none"> 1. Adjust mitre gauge. |

IMPORTANT: Please note all repairs/service should be carried out by a qualified person.

13. EXPLANATION OF SYMBOLS

13.1 EXPLANATION OF SYMBOLS



Warning!
Wear dust mask.



Danger of
electrocution



Warning!
Wear goggles.



Do not use without
blade guard.



Warning!
Read the instruction
Manual



Avoid operation in damp
conditions.



Avoid wearing loose
clothing that could catch
in moving parts.



Warning!
Wear ear defenders.



Ensure table saw is
regularly maintained.



Single value noise marking.
(maximum declared
A-Weighted sound power
level in decibels).



Keep hands away from saw
blades.



WEEE
Do not dispose of Waste
Electrical & Electronic
Equipment in with domestic
rubbish.

14. DISPOSAL

14.1 DISPOSAL

- At the end of the machine's working life, or when it can no longer be repaired, ensure that it is disposed of according to national regulations.
- Contact your local authority for details of collection schemes in your area.

In all circumstances:

- Do not dispose of power tools with domestic waste.
- Do not incinerate.
- Do not abandon in the environment.
- Do not dispose of WEEE* as unsorted municipal waste.



* Waste Electrical & Electronic Equipment.

15. GLOSSARY

15.1 GLOSSARY

Alphabetical list of words relating to this manual

| | |
|-------------------------|---|
| BEVELLING | An angle cutting operation through the face of the work piece. |
| BLADE TOOTH SET | The distance that the teeth of the saw blade are bent (on set) outward from the side of the blade. |
| COMPOUND CUTTING | A simultaneous bevel and mitre cutting operation. |
| CROSS CUT | A cutting operation made across the grain of the wood. |
| FEATHERBOARD | A device which can help guide work pieces during rip type operation. |
| HEEL | Misalignment of the blade. |
| KERF | The material which is removed by the blade in a through cut or the slot produced by the blade in a non-through or partial cut. |
| KICKBACK | An uncontrolled grabbing, and throwing of the work piece back toward the front of the saw during a rip type operation. |
| LEADING EDGE | The edge of the work piece which is pushed into the blade first. |
| MITRING | An angle cutting operation through the face of the work piece. |
| PUSH BLOCK | A device used for ripping type operations too narrow to allow use of a push stick. |
| PUSH STICK | A device used to feed the work piece through the saw during narrow ripping type operation and which helps keep the operator's hands well away from the blade. |
| RABBET | A notch in the edge of a work piece. |
| RESIN | A sticky sap-based substance that has dried. |
| RIPPING | A cutting operation along the length of the work piece - in the direction of the grain. |
| RIVING KNIFE | Positioned behind the saw blade to prevent wood closing and jamming after being cut. |
| SAW BLADE PATH | The area of the work piece directly in line with and moving towards the saw blade edge. |
| TRAILING EDGE | The work piece edge last cut by the saw blade. |
| WORK PIECE | The item on which the cutting operation is being performed. The surfaces of the work piece are commonly referred to as faces, ends and edges. |

- **DRAPER TOOLS LIMITED,**
Hursley Road, Chandler's Ford,
Eastleigh, Hampshire. SO53 1YF. U.K.
- **Helpline:** (023) 8049 4344
- **Sales Desk:** (023) 8049 4333
- **General Enquiries:** (023) 8026 6355
- **Service/Warranty Repair Agent**
For aftersales servicing or warranty repairs, please
contact the Draper Tools Helpline for details of an
agent in your local area.

YOUR DRAPER STOCKIST

RWMC1115

