

DRAPER®

SPARE PARTS LISTING & DRAWING SHEET FOR 400W Lawn Raker

Stock No.82765 Part No.LR400B

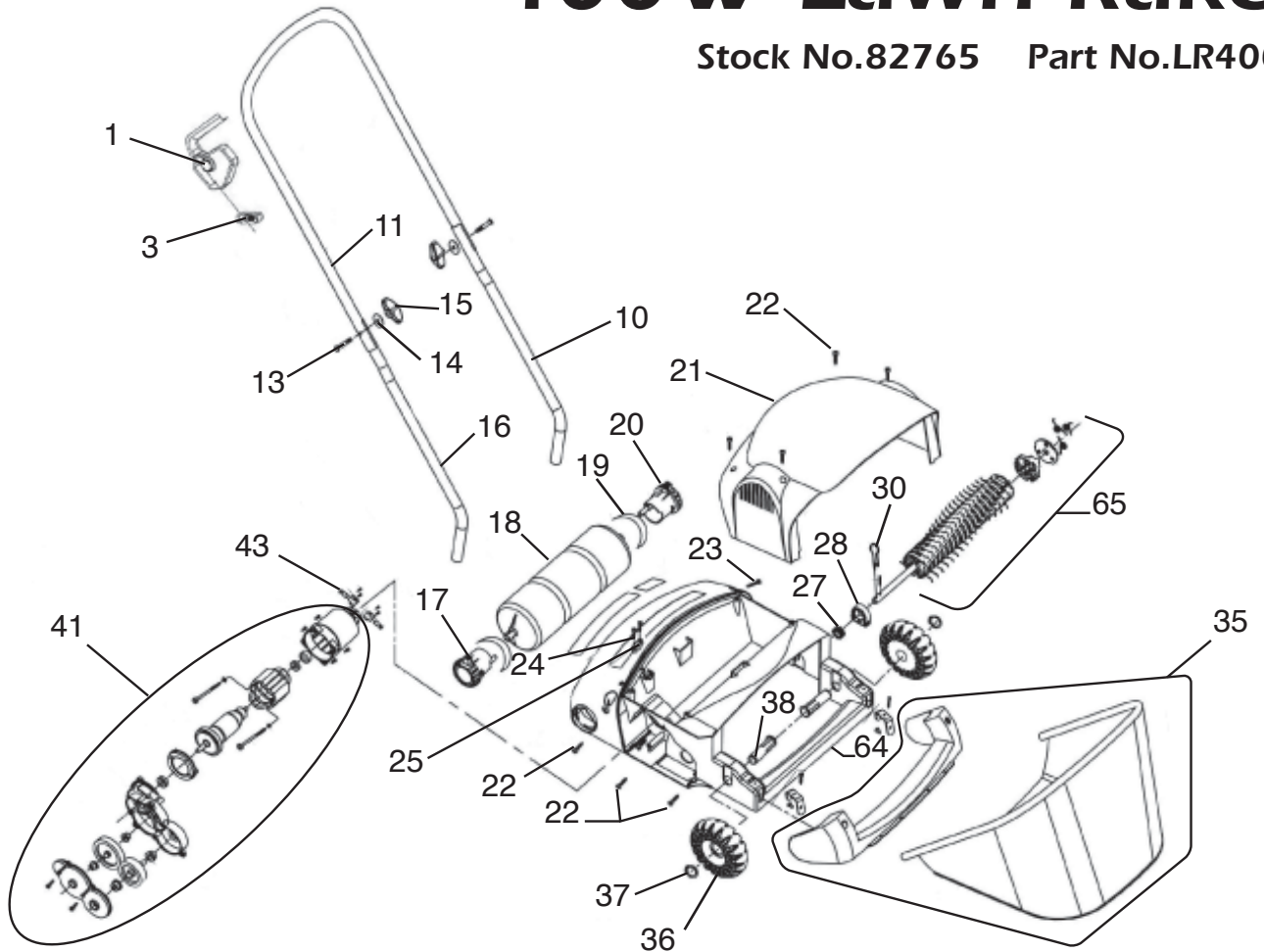

KEY No.	PART No.	STOCK No.	DESCRIPTION
1	YGP-2037100	75124	Switch c/w. BS moulded plug & cable
3	YGP-409570	61705	Cable strain restraint
10	YGP-2036740	78436	Lower handle (LH)
11	YGP-2037110	75126	Upper handle
13	YGP-1036670	75128	Bolt
14	YGP-1036680	75129	Washer
15	YGP-2036660	75130	Knob
16	YGP-2036700	75131	Lower handle (RH)
17	YGP-2036750	75132	Rear roller knob (RH)
18	YGP-2036770	75133	Roller
19	YGP-2036780	75134	Spring
20	YGP-2036760	75135	Rear roller knob (LH)
21	YGP-2058250	47040	Cover
22	YGP-1036710	75137	Screw

KEY No.	PART No.	STOCK No.	DESCRIPTION
23	YGP-1036720	78437	Screw
24	YGP-1036730	78438	Screw
25	YGP-2036800	75138	Cable strain
27	YGP-2036810	75140	Gear shape bearing
28	YGP-2036820	75141	Bearing seat
30	YGP-2036830	75143	Spring locking pin
35	YGP-2036870	75145	Grass collection assembly
36	YGP-2036850	75146	Wheel
37	YGP-1036740	75147	Circlip
38	YGP-2036860	75148	Shaft
41	YGP-2036880	75164	Motor & gear box assembly
43	YGP-2036890	75153	Carbon brush assembly
64	YGP-2036920	75174	Body shell
65	YAGP1	74902	Complete rake drum & tine

Helpline: (023) 8049 4344. Sales Desk: (023) 8049 4333. General Enquiries: (023) 8026 6355.

DRAPER TOOLS LTD, HURSLEY ROAD, CHANDLER'S FORD, EASTLEIGH, HANTS. SO53 1YF. U.K. internet: www.drapertools.com e-mail: sales@drapertools.com

RDMC170715