

DRAPER[®]

STORMFORCE

INSTRUCTIONS FOR
130W 230V
Tri-Palm Sander

Stock No.83645 Part No.PT130SF

IMPORTANT: PLEASE READ THESE INSTRUCTIONS CAREFULLY TO ENSURE THE SAFE AND EFFECTIVE USE OF THIS PRODUCT.



DRAPER[®]

GENERAL INFORMATION

These instructions accompanying the product are the original instructions. This document is part of the product, keep it for the life of the product passing it on to any subsequent holder of the product. Read all these instructions before assembling, operating or maintaining this product.

This manual has been compiled by Draper Tools describing the purpose for which the product has been designed, and contains all the necessary information to ensure its correct and safe use. By following all the general safety instructions contained in this manual, it will ensure both product and operator safety, together with longer life of the product itself.

All photographs and drawings in this manual are supplied by Draper Tools to help illustrate the operation of the product.

Whilst every effort has been made to ensure the accuracy of information contained in this manual, the Draper Tools policy of continuous improvement determines the right to make modifications without prior warning.

1. TITLE PAGE

1.1 INTRODUCTION:

USER MANUAL FOR:

130W 230V TRI-PALM SANDER

Stock no. 83645

Part no. PT130SF

1.2 REVISIONS:

Date first published April 2016

As our user manuals are continually updated, users should make sure that they use the very latest version.

Downloads are available from: <http://www.drapertools.com/manuals>

DRAPER TOOLS LIMITED

HURSLEY ROAD

CHANDLER'S FORD

EASTLEIGH

HAMPSHIRE

SO53 1YF

UK

WEBSITE: drapertools.com

PRODUCT HELP LINE: +44 (0) 23 8049 4344

GENERAL FAX: +44 (0) 23 8026 0784

1.3 UNDERSTANDING THIS MANUALS SAFETY CONTENT:

WARNING! Information that draws attention to the risk of injury or death.

CAUTION! Information that draws attention to the risk of damage to the product or surroundings.

1.4 COPYRIGHT © NOTICE:

Copyright © Draper Tools Limited.

Permission is granted to reproduce this publication for personal & educational use only.

Commercial copying, redistribution, hiring or lending is prohibited.

No part of this publication may be stored in a retrieval system or transmitted in any other form or means without written permission from Draper Tools Limited.

In all cases this copyright notice must remain intact.

2. CONTENTS

2.1 CONTENTS

	PAGE CONTENT	PAGE
1	TITLE PAGE	
	1.1 INTRODUCTION	2
	1.2 REVISION HISTORY.....	2
	1.3 UNDERSTANDING THIS MANUAL	2
	1.4 COPYRIGHT NOTICE.....	2
2	CONTENTS	
	2.1 CONTENTS	3
3	GUARANTEE	
	3.1 GUARANTEE	4
4	INTRODUCTION	
	4.1 SCOPE	5
	4.2 SPECIFICATION	5
	4.3 HANDLING & STORAGE	5
5	HEALTH & SAFETY INFORMATION	
	5.1 GENERAL SAFETY INSTRUCTIONS FOR POWER TOOL USE	6 - 7
	5.2 ADDITIONAL SAFETY INSTRUCTIONS FOR SANDER USE	7
	5.3 CONNECTION TO THE POWER SUPPLY	7
6	TECHNICAL DESCRIPTION	
	6.1 IDENTIFICATION	8
7	UNPACKING & CHECKING	
	7.1 PACKAGING.....	9
	7.2 WHAT'S IN THE BOX?	9
8	SETTING UP THE SANDER	
	8.1 SWITCHING ON/OFF	10
	8.2 ABRASIVE SHEET INSTALLATION / REPLACEMENT.....	10
	8.3 ABRASIVE PAPER.....	10
	8.4 DUST EXTRACTION FACILITY.....	11
9	OPTIONAL ACCESSORIES	
	9.1 OPTIONAL ACCESSORIES	12
10	TROUBLESHOOTING	
	10.1 TROUBLESHOOTING	13
11	MAINTENANCE	
	11.1 MAINTENANCE AND PARTS REPLACEMENT	13
12	EXPLANATION OF SYMBOLS	
	12.1 EXPLANATION OF SYMBOLS	14
13	DISPOSAL	
	13.1 DISPOSAL.....	15
	DECLARATION OF CONFORMITY	ENCLOSED

3. GUARANTEE

3.1 *GUARANTEE*

Draper tools have been carefully tested and inspected before shipment and are guaranteed to be free from defective materials and workmanship.

Should the tool develop a fault, please return the complete tool to your nearest distributor or contact Draper Tools Limited, Chandler's Ford, Eastleigh, Hampshire, SO53 1YF. England.

Telephone Sales Desk: (023) 8049 4333 or Product Help Line (023) 8049 4344.

A proof of purchase must be provided with the tool.

If upon inspection it is found that the fault occurring is due to defective materials or workmanship, repairs will be carried out free of charge. This guarantee period covering parts/labour is 12 months from the date of purchase except where tools are hired out when the guarantee period is 90 days from the date of purchase. The guarantee is extended to 24 months for parts only. This guarantee does not apply to normal wear and tear, nor does it cover any damage caused by misuse, careless or unsafe handling, alterations, accidents, or repairs attempted or made by any personnel other than the authorised Draper warranty repair agent.

Note: If the tool is found not to be within the terms of warranty, repairs and carriage charges will be quoted and made accordingly.

This guarantee applies in lieu of any other guarantee expressed or implied and variations of its terms are not authorised.

Your Draper guarantee is not effective unless you can produce upon request a dated receipt or invoice to verify your proof of purchase within the guarantee period.

Please note that this guarantee is an additional benefit and does not affect your statutory rights.

Draper Tools Limited.

4. INTRODUCTION

4.1 SCOPE

This machine is designed for light surface preparation and other detail work on wood and similar materials. It is intended for domestic and light commercial use only. Any other application is considered misuse.

4.2 SPECIFICATION

Stock no	83645
Part no	PT130SF
Motor:	
Rated voltage	230V~
Rated frequency	50Hz
Rated input	130W
Revolutions per minute (no load)	13,000min ⁻¹
Pad size	95x140x140mm
Sound pressure level	75.0dB(A)
Sound power level	86.0dB(A)
Vibration level	4.4m/s ²
Weight (machine only)	1.0kg

4.3 HANDLING & STORAGE

The environment will have a negative result on its operation if you are not careful. If the air is damp, components will rust. If the machine is unprotected from dust and debris; components will become clogged: And if not cleaned and maintained correctly or regularly the machine will not perform at its best.

5. HEALTH & SAFETY INFORMATION

5.1 GENERAL SAFETY INSTRUCTIONS

General Power Tools Safety Warnings

Warning: Read all instructions. Failure to follow all instructions listed below may result in electric shock, fire and/or serious injury.

Save all warnings and instructions for future reference.

The term "power tool" in the warnings refers to your mains operated (corded) power tool or battery operated (cordless) power tool.

1) Work area safety

- a) **Keep work area clean and well lit.** Cluttered or dark areas invite accidents.
- b) **Do not operate power tools in explosive atmospheres, such as in the presence of flammable liquids, gases or dust.** Power tools create sparks which may ignite the dust or fumes.
- c) **Keep children and bystanders away while operating a power tool.** Distractions can cause you to lose control.

2) Electrical Safety

- a) **Power tool plugs must match the outlet.** Never modify the plug in any way. Do not use any adapter plugs with earthed (grounded) power tools. Unmodified plugs and matching outlets will reduce risk of electrical shock.
- b) **Avoid body contact with earthed or grounded surfaces such as pipes, radiators, ranges and refrigerators.** There is an increased risk of electric shock if your body is earthed or grounded.
- c) **Do not expose power tools to rain or wet conditions.** Water entering a power tool will increase the risk of electric shock.
- d) **Do not abuse the cord. Never use the cord for carrying, pulling or unplugging the power tool.** Keep cord away from heat, oil, sharp edges or moving parts. Damaged or entangled cords increase the risk of electric shock.
- e) **When operating a power tool outdoors, use an extension cord suitable for outdoor use.** Use of a cord suitable for outdoor use reduces the risk of electric shock.
- f) **If operating a power tool in a damp location is unavoidable, use a residual current device (RCD) protected supply.** Use of an RCD reduces the risk of electric shock.

3) Personal Safety

- a) **Stay alert, watch what you are doing and use common sense when operating a power tool. Do not use a power tool while you are tired or under the influence of drugs, alcohol or medication.** A moment of inattention while operating power tools may result in serious personal injury.
- b) **Use personal protective equipment. Always wear eye protection.** Protective equipment such as dust mask, nonskid safety shoes, hard hat, or hearing protection used for appropriate conditions will reduce personal injuries.
- c) **Prevent unintentional starting. Ensure the switch is in the off position before connecting to power source and/or battery pack, picking up or carrying the tool.** Carrying power tools with your finger on the switch or energising power tools that have the switch on invites accidents.
- d) **Remove any adjusting key or wrench before turning the power tool on.** A wrench or a key left attached to a rotating part of the power tool may result in personal injury.
- e) **Do not overreach. Keep proper footing and balance at all times.** This enables better control of the power tool in unexpected situations.
- f) **Dress properly. Do not wear loose clothing or jewellery. Keep your hair, clothing and gloves away from moving parts.** Loose clothes, jewellery or long hair can be caught in moving parts.

5. HEALTH & SAFETY INFORMATION

g) If devices are provided for the connection of dust extraction and collection facilities, ensure these are connected and properly used. Use of dust collection can reduce dust related hazards.

4) Power Tool Use And Care

a) Do not force the power tool. Use the correct power tool for your application. The correct power tool will do the job better and safer at the rate for which it was designed.

b) Do not use the power tool if the switch does not turn it on and off. Any power tool that cannot be controlled with the switch is dangerous and must be repaired.

c) Disconnect the plug from the power source and/or the battery pack from the power tool before making any adjustments, changing accessories, or storing power tools. Such preventive safety measures reduce the risk of starting the power tool accidentally.

d) Store idle power tools out of the reach of children and do not allow persons unfamiliar with the power tool or these instructions to operate the power tool. Power tools are dangerous in the hands of untrained users.

e) Maintain power tools. Check for misalignment or binding of moving parts, breakage of parts and any other condition that may affect the power tools operation. If damaged, have the power tool repaired before use. Many accidents are caused by poorly maintained power tools.

f) Keep cutting tools sharp and clean. Properly maintained cutting tools with sharp cutting edges are less likely to bind and are easier to control.

g) Use the power tool, accessories and tool bits etc., in accordance with these instructions, taking into account the working conditions and the work to be performed. Use of the power tool for operations different from intended could result in a hazardous situation.

5) Service

a. Have your power tool serviced by a qualified repair person using only identical replacement parts. This will ensure that the safety of the power tool is maintained.

5.2 ADDITIONAL SAFETY INSTRUCTIONS FOR SANDERS

- Wear dust protection with sanders. Exposure to dust can be detrimental to health.
- Connect dust extraction equipment. If the tool is provided for the connection of dust extraction and collecting equipment, ensure these are connected and properly used.

5.3 CONNECTION TO THE POWER SUPPLY

Make sure the power supply information on the machine's rating plate are compatible with the power supply you intend to connect it to.

This product comes supplied with a UK standard 3 pin plug fitted. It is designed for connection to a domestic power supply rated at 230V AC.

This appliance is Class II† and is designed for connection to a power supply matching that detailed on the rating label and compatible with the plug fitted.

If an extension lead is required, use an approved and compatible lead rated for this appliance. Follow all the instruction supplied with the extension lead.

†Double insulated : This product requires no earth connection as supplementary insulation is applied to the basic insulation to protect against electric shock in the event of failure of the basic insulation.

Apart from replacing the fuse in the plug, no other electrical work is recommended on this machine.

6. TECHNICAL DESCRIPTION

6.1 IDENTIFICATION



- ① Palm grip
- ② Switch
- ③ Motor ventilation grilles

- ④ Dust outlet
- ⑤ Base pad
- ⑥ Plug and cable

7. UNPACKING & CHECKING

7.1 PACKAGING

Carefully remove the tri-palm sander from the packaging and examine it for any sign of damage that may have happened during shipping. Lay the contents out and check them against the parts shown below. If any part is damaged or missing; please contact the Draper Help Line (the telephone number appears on the Title page) and do not attempt to use the power tool.

The packaging material should be retained at least during the guarantee period: in case the machine needs to be returned for repair.

Warning! Some of the packaging materials used may be harmful to children. Do not leave any of these materials in the reach of children.

If any of the packaging is to be thrown away, make sure they are disposed of correctly; according to local regulations.

7.2 WHAT'S IN THE BOX?

As well as the tri-palm sander; there are several parts not fitted or attached to it.

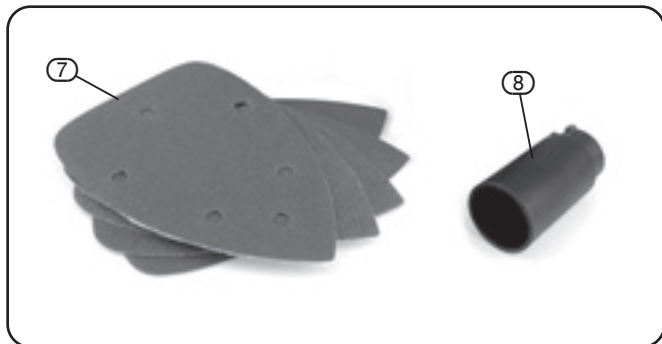

⑦ 5 x assorted sanding sheets (hook and loop backed)

⑧ Dust extraction adaptor

8. SETTING UP THE SANDER

NOTE: Remove the plug from the socket before carrying out adjustment, servicing or maintenance.

8.1 SWITCHING ON/OFF - FIG. 1

Ensure the sander is raised off the workpiece.

To start the sander place the switch (2) to the "I" position. To stop the sander place the switch into the "O" position.

This machine is intended for light/medium duty sanding of wood and similar materials only.

Apply equal pressure on the workpiece with the base pad remaining flat. Attempting to sand areas using only the edge will lead to damage to the base pad.

NOTE: Excess pressure when sanding reduces the effectiveness of tool and will cause the motor to overload.

Do not overload this machine.

Abrasive sheets are consumable items. Replace abrasive sheets when clogged with material or when surface/edge has rips, cracks or worn areas.

8.2 ABRASIVE SHEET INSTALLATION / REPLACEMENT - FIG. 2

The sanding sheets are simply pressed onto the base pad. The holes in the sander must correspond to the holes in the sanding sheet for maximum dust extraction.

8.3 ABRASIVE PAPER

Only use good quality abrasive paper as this will improve the sanding efficiency and reduce working time. Use coarse grade (40, 60, or 80) sanding sheets when large quantities of material need to be removed. For finishing operations use 120 grade sanding sheets. (See Optional Accessories, page 11).

Replace abrasive sheets when clogged with material or when surface/edge has rips, cracks or worn areas.

NOTE: Abrasive sheets and the sander base pad are consumable items.

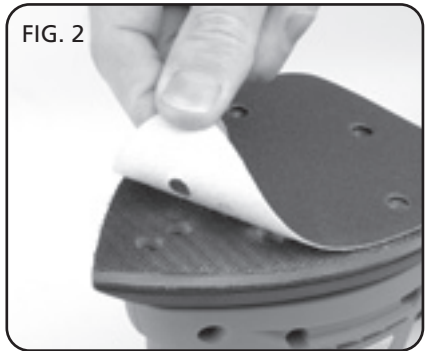
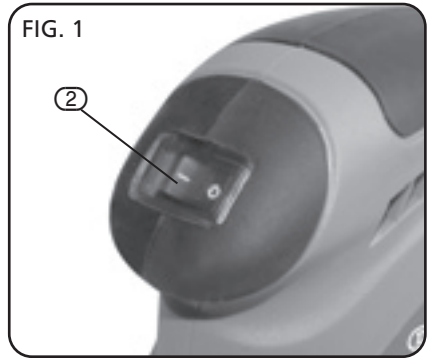

8. SETTING UP THE SANDER

8.4 DUST EXTRACTION FACILITY - FIG. 3

Inhalation of dust particles can be detrimental to health. For larger jobs it is recommended that the dust extraction facility is used in conjunction with a suitable vacuum cleaner (4.1).

The dust extraction port (8) is fitted by inserting the bayonet end into the rear of the sander and then twisting it through approximately 90°. This will then lock the port in place ready to receive a connection to a suitable dust extractor/vacuum cleaner.

NOTE: Due to the outlet diameter, a size adaptation may be necessary.

All wood dust (including dust from composites like chipboards and fibre boards etc) is hazardous to health; it can affect the nose, the respiratory system and the skin. For example MDF (medium density fibreboard) which contains formaldehyde is a known carcinogen. In addition to the above measures a correctly fitted dust mask, suitable for the activity and in accordance to the relevant standard, must be worn.

For work activities involving exposure to fine wood dust, a mask rated to at least FFP2 should be used.

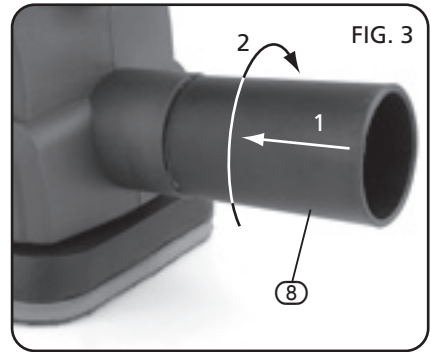

9. OPTIONAL ACCESSORIES

9.1 OPTIONAL ACCESSORIES

Title	Stock No.	Part No.	Size	Grit	Packed
Triangular Sanding Sheets	36060	APT140B	95 x 140 x 140mm	60	10
Triangular Sanding Sheets	36061	APT140B	95 x 140 x 140mm	80	10
Triangular Sanding Sheets	36062	APT140B	95 x 140 x 140mm	120	10
Triangular Sanding Sheets	36064	APT140B	95 x 140 x 140mm	240	10
Triangular Sanding Sheets	23074	APT140B	95 x 140 x 140mm	320	10
Triangular Sanding Sheets	23075	APT140B	95 x 140 x 140mm	400	10
Triangular Sanding Sheets	31977	APT140B	95 x 140 x 140mm	Assorted	10

10. TROUBLESHOOTING

10.1 TROUBLESHOOTING

WARNING: For your own safety, turn the switch off and remove the plug from the power supply socket.

PROBLEM	POSSIBLE CAUSE	REQUIRED ACTION
<ul style="list-style-type: none">• Motor does not start.	<ul style="list-style-type: none">• Fuse.• Brushes worn.• Other.	<ul style="list-style-type: none">• 5 amp time delay fuse or circuit breaker.• Have brushes replaced.• Contact an authorised service centre.
<ul style="list-style-type: none">• Reduced sanding efficiency.	<ul style="list-style-type: none">• Abrasive sheet worn, clogged or cracked.	<ul style="list-style-type: none">• Replace abrasive sheet †

† A range of accessory abrasive sheets are available from your local Draper stockist. Abrasive sheets and the base pad are both considered consumable items.

IMPORTANT: Please note all repairs/service should be carried out by a qualified person.

11. MAINTENANCE

11.1 MAINTENANCE AND PARTS REPLACEMENT

Regular inspection and cleaning reduces the necessity for maintenance operations and will keep your tool in good working condition.

The motor must be correctly ventilated during tool operation. For this reason avoid blocking the air inlets. After use disconnect the tool from the power supply and vacuum the ventilation slots.

If the replacement of the supply cord is necessary, this has to be done by the manufacturer or his agent in order to avoid a safety hazard.

12. EXPLANATION OF SYMBOLS

12.1 EXPLANATION OF SYMBOLS



Warning!
Wear dust mask.



Warning!
Read the instruction manual



Warning!
Wear suitable eye/face
protection.



Warning!
Wear ear defenders.



WEEE
Do not dispose of Waste Electrical
& Electronic Equipment in with
domestic rubbish



Class II construction
(Double insulated).

13. DISPOSAL

13.1 DISPOSAL

- At the end of the machine's working life, or when it can no longer be repaired, ensure that it is disposed of according to national regulations.
- Contact your local authority for details of collection schemes in your area.

In all circumstances:

- Do not dispose of power tools with domestic waste.
- Do not incinerate.
- Do not abandon in the environment.
- Do not dispose of WEEE* as unsorted municipal waste.



* Waste Electrical & Electronic Equipment.

- **DRAPER TOOLS LIMITED,**
Hursley Road, Chandler's Ford,
Eastleigh, Hampshire. SO53 1YF. U.K.
- **Help Line:** (023) 8049 4344
- **Sales Desk:** (023) 8049 4333
- **General Enquiries:** (023) 8026 6355
- **Service/Warranty Repair Agent**
For aftersales servicing or warranty repairs, please
contact the Draper Tools Help Line for details of an
agent in your local area.

YOUR DRAPER STOCKIST

RDCH0816

