

DRAPER[®]

STORMFORCE

INSTRUCTIONS FOR
**135W 230V Rotary Multi-Tool Kit
with Flexible Drive Shaft**

Stock No.83652 Part No.PT142KSF

IMPORTANT: PLEASE READ THESE INSTRUCTIONS CAREFULLY TO ENSURE THE SAFE AND EFFECTIVE USE OF THIS PRODUCT.

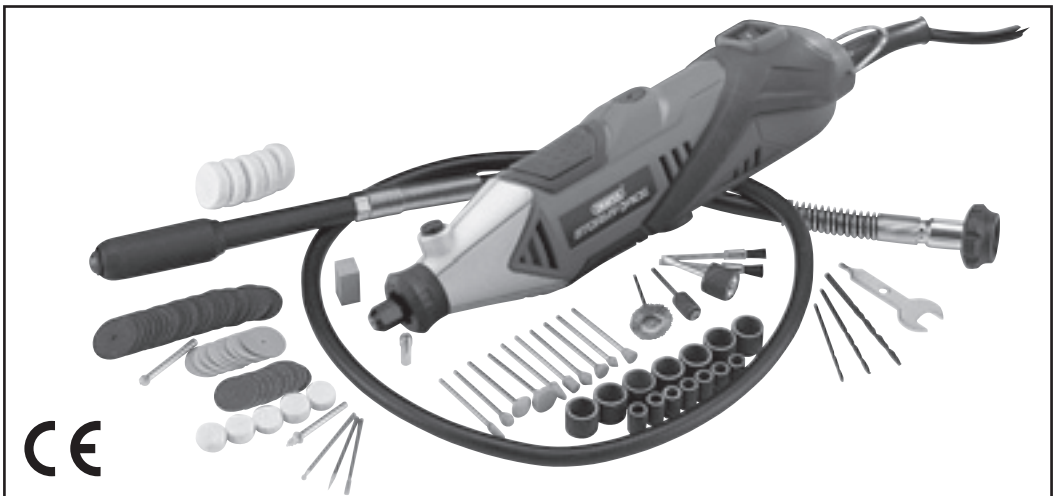

DRAPER[®]

GENERAL INFORMATION

These instructions accompanying the product are the original instructions. This document is part of the product, keep it for the life of the product passing it on to any subsequent holder of the product. Read all these instructions before assembling, operating or maintaining this product.

This manual has been compiled by Draper Tools describing the purpose for which the product has been designed, and contains all the necessary information to ensure its correct and safe use. By following all the general safety instructions contained in this manual, it will ensure both product and operator safety, together with longer life of the product itself.

All photographs and drawings in this manual are supplied by Draper Tools to help illustrate the operation of the product.

Whilst every effort has been made to ensure the accuracy of information contained in this manual, the Draper Tools policy of continuous improvement determines the right to make modifications without prior warning.

1. TITLE PAGE

1.1 INTRODUCTION:

USER MANUAL FOR:

135W 230V ROTORY MULTI-TOOL KIT WITH FLEXIBLE DRIVE SHAFT

Stock no. 83652

Part no. PT142KSF

1.2 REVISIONS:

Date first published March 2016

As our user manuals are continually updated, users should make sure that they use the very latest version.

Downloads are available from: <http://www.drapertools.com/manuals>

DRAPER TOOLS LIMITED

HURSLEY ROAD

CHANDLER'S FORD

EASTLEIGH

HAMPSHIRE

SO53 1YF

UK

WEBSITE: drapertools.com

PRODUCT HELP LINE: +44 (0) 23 8049 4344

GENERAL FAX: +44 (0) 23 8026 0784

1.3 UNDERSTANDING THIS MANUALS SAFETY CONTENT:

WARNING! Information that draws attention to the risk of injury or death.

CAUTION! Information that draws attention to the risk of damage to the product or surroundings.

1.4 COPYRIGHT © NOTICE:

Copyright © Draper Tools Limited.

Permission is granted to reproduce this publication for personal & educational use only.

Commercial copying, redistribution, hiring or lending is prohibited.

No part of this publication may be stored in a retrieval system or transmitted in any other form or means without written permission from Draper Tools Limited.

In all cases this copyright notice must remain intact.

2. CONTENTS

2.1 CONTENTS

	PAGE CONTENT	PAGE
1	TITLE PAGE	
	1.1 INTRODUCTION	2
	1.2 REVISION HISTORY	2
	1.3 UNDERSTANDING THIS MANUAL	2
	1.4 COPYRIGHT NOTICE	2
2	CONTENTS	
	2.1 CONTENTS	3
3	GUARANTEE	
	3.1 GUARANTEE	4
4	INTRODUCTION	
	4.1 SCOPE	5
	4.2 SPECIFICATION	5
	4.3 HANDLING & STORAGE	5
5	HEALTH & SAFETY INFORMATION	
	5.1 GENERAL SAFETY INSTRUCTIONS	6-7
	5.2 ADDITIONAL SAFETY INSTRUCTIONS FOR MULTI-TOOL USE	7-8
	5.3 CONNECTION TO THE POWER SUPPLY	8
6	TECHNICAL DESCRIPTION	
	6.1 IDENTIFICATION	9
7	UNPACKING & CHECKING	
	7.1 PACKAGING	10
	7.2 WHAT'S IN THE BOX?	10
8	BASIC MULTI-TOOL OPERATIONS	
	8.1 ACCESSORY INSTALLATION/ REPLACEMENT	11
	8.2 FITTING FLEXIBLE DRIVE SHAFT	11
	8.3 SWITCHING ON AND OFF	11
	8.4 APPLICATIONS	12
	8.5 HOLDING THE TOOL	12
	8.6 FITTING A CUTTING/SANDING DISC	12
	8.7 FITTING THE SANDING DRUMS	12
9	MAINTENANCE	
	9.1 MAINTENANCE & PARTS REPLACEMENT	13
10	OPTIONAL ACCESSORIES	14
11	EXPLANATION OF SYMBOLS	
	11.1 EXPLANATION OF SYMBOLS	15
12	DISPOSAL	
	12.1 DISPOSAL	15
	DECLARATION OF CONFORMITY	ENCLOSED

3. GUARANTEE

3.1 *GUARANTEE*

Draper tools have been carefully tested and inspected before shipment and are guaranteed to be free from defective materials and workmanship.

Should the tool develop a fault, please return the complete tool to your nearest distributor or contact Draper Tools Limited, Chandler's Ford, Eastleigh, Hampshire, SO53 1YF. England.

Telephone Sales Desk: (023) 8049 4333 or Product Help Line (023) 8049 4344.

A proof of purchase must be provided with the tool.

If upon inspection it is found that the fault occurring is due to defective materials or workmanship, repairs will be carried out free of charge. This guarantee period covering parts/labour is 12 months from the date of purchase except where tools are hired out when the guarantee period is 90 days from the date of purchase. The guarantee is extended to 24 months for parts only. This guarantee does not apply to normal wear and tear, nor does it cover any damage caused by misuse, careless or unsafe handling, alterations, accidents, or repairs attempted or made by any personnel other than the authorised Draper warranty repair agent.

Note: If the tool is found not to be within the terms of warranty, repairs and carriage charges will be quoted and made accordingly.

This guarantee applies in lieu of any other guarantee expressed or implied and variations of its terms are not authorised.

Your Draper guarantee is not effective unless you can produce upon request a dated receipt or invoice to verify your proof of purchase within the guarantee period.

Please note that this guarantee is an additional benefit and does not affect your statutory rights.

Draper Tools Limited.

4. INTRODUCTION

4.1 SCOPE

For drilling, milling, grinding, engraving, cutting, polishing, sharpening, buffing and removing rust, etc. This tool is intended for domestic and light commercial use only. Any other application is considered as misuse.

4.2 SPECIFICATION

Stock No.....	83652
Part No.....	PT142KSF
Rated voltage.....	230V~50Hz
Rated input.....	135W
Speed (no load).....	10,000-38,000min ⁻¹
Collet capacity.....	3(2.0, 2.4, and 3.0mm)
Sound pressure level.....	77dB(A)
Sound power level.....	88dB(A)
Vibration level.....	2.3m/s ²
Weight (Excluding Accessories).....	700g
Collet nut.....	M7
Maximum diameter.....	ø35

4.3 HANDLING & STORAGE

Although this machine is small in size, care must still be taken when handling.

This machine is not a toy and must be respected.

The environment will have a negative result on its operation if you are not careful. If the air is damp, components will rust. If the machine is unprotected from dust and debris; components will become clogged: And if not cleaned and maintained correctly or regularly the machine will not perform at its best.

5. HEALTH & SAFETY INFORMATION

5.1 GENERAL SAFETY INSTRUCTIONS

General Power Tools Safety Warnings

WARNING: Read all instructions. Failure to follow all instructions listed below may result in electric shock, fire and/or serious injury.

Save all warnings and instructions for future reference.

The term "power tool" in the warnings refers to your mains operated (corded) power tool or battery operated (cordless) power tool.

1) Work area safety

- a) **Keep work area clean and well lit.** Cluttered or dark areas invite accidents.
- b) **Do not operate power tools in explosive atmospheres, such as in the presence of flammable liquids, gases or dust.** Power tools create sparks which may ignite the dust or fumes.
- c) **Keep children and bystanders away while operating a power tool.** Distractions can cause you to lose control.

2) Electrical Safety

- a) **Power tool plugs must match the outlet.** Never modify the plug in any way. Do not use any adapter plugs with earthed (grounded) power tools. Unmodified plugs and matching outlets will reduce risk of electrical shock.
- b) **Avoid body contact with earthed or grounded surfaces such as pipes, radiators, ranges and refrigerators.** There is an increased risk of electric shock if your body is earthed or grounded.
- c) **Do not expose power tools to rain or wet conditions.** Water entering a power tool will increase the risk of electric shock.
- d) **Do not abuse the cord. Never use the cord for carrying, pulling or unplugging the power tool.** Keep cord away from heat, oil, sharp edges or moving parts. Damaged or entangled cords increase the risk of electric shock.
- e) **When operating a power tool outdoors, use an extension cord suitable for outdoor use.** Use of a cord suitable for outdoor use reduces the risk of electric shock.
- f) **If operating a power tool in a damp location is unavoidable, use a residual current device (RCD) protected supply.** Use of an RCD reduces the risk of electric shock.

3) Personal Safety

- a) **Stay alert, watch what you are doing and use common sense when operating a power tool. Do not use a power tool while you are tired or under the influence of drugs, alcohol or medication.** A moment of inattention while operating power tools may result in serious personal injury.
- b) **Use personal protective equipment. Always wear eye protection.** Protective equipment such as dust mask, nonskid safety shoes, hard hat, or hearing protection used for appropriate conditions will reduce personal injuries.
- c) **Prevent unintentional starting. Ensure the switch is in the off position before connecting to power source and/or battery pack, picking up or carrying the tool.** Carrying power tools with your finger on the switch or energising power tools that have the switch on invites accidents.
- d) **Remove any adjusting key or wrench before turning the power tool on.** A wrench or a key left attached to a rotating part of the power tool may result in personal injury.
- e) **Do not overreach. Keep proper footing and balance at all times.** This enables better control of the power tool in unexpected situations.
- f) **Dress properly. Do not wear loose clothing or jewellery. Keep your hair, clothing and gloves away from moving parts.** Loose clothes, jewellery or long hair can be caught in moving parts.

5. HEALTH & SAFETY INFORMATION

g) If devices are provided for the connection of dust extraction and collection facilities, ensure these are connected and properly used. Use of dust collection can reduce dust related hazards.

4) Power Tool Use And Care

- a) **Do not force the power tool. Use the correct power tool for your application.** The correct power tool will do the job better and safer at the rate for which it was designed.
- b) **Do not use the power tool if the switch does not turn it on and off.** Any power tool that cannot be controlled with the switch is dangerous and must be repaired.
- c) **Disconnect the plug from the power source and/or the battery pack from the power tool before making any adjustments, changing accessories, or storing power tools.** Such preventive safety measures reduce the risk of starting the power tool accidentally.
- d) **Store idle power tools out of the reach of children and do not allow persons unfamiliar with the power tool or these instructions to operate the power tool.** Power tools are dangerous in the hands of untrained users.
- e) **Maintain power tools. Check for misalignment or binding of moving parts, breakage of parts and any other condition that may affect the power tools operation. If damaged, have the power tool repaired before use.** Many accidents are caused by poorly maintained power tools.
- f) **Keep cutting tools sharp and clean.** Properly maintained cutting tools with sharp cutting edges are less likely to bind and are easier to control.
- g) **Use the power tool, accessories and tool bits etc., in accordance with these instructions, taking into account the working conditions and the work to be performed.** Use of the power tool for operations different from intended could result in a hazardous situation.

5) Service

- a. **Have your power tool serviced by a qualified repair person using only identical replacement parts.** This will ensure that the safety of the power tool is maintained.

5.2 ADDITIONAL SAFETY INSTRUCTIONS FOR MULTI-TOOL USE

Sander Safety Warning

1) Personal Safety

- a) Wear dust protection with sanders. Exposure to dust can be detrimental to health.
- b) Connect dust extraction equipment. If the tool is provided for the connection of dust extraction and collecting equipment, ensure these are connected and properly used.

Working hints for your tool.

- If your power tool becomes too hot, especially when used at low speed, set the speed to maximum and run it with no load for 2-3minutes to cool the motor. Avoid prolonged usage at very low speeds. Always keep the blade sharp.
- Always ensure the workpiece is firmly held or clamped to prevent movement.
- Any movement of the material may effect the quality of the cutting or sanding finish.
- Start your tool before working and turn it off only after you stop working.
- Do not start sanding without having the sandpaper fitted.
- Do not allow the sandpaper to wear away, it will damage the sanding pad. The guarantee does not cover sanding pad wear and tear.
- Use coarse grit paper to sand rough surfaces, medium grit for smooth surfaces and fine grit for the finishing surfaces. If necessary, first make a test run on scrap material.
- Excessive force will reduce the working efficiency and cause motor overload. Replacing the accessory regularly will maintain optimum working efficiency.

Maintain tool with care

5. HEALTH & SAFETY INFORMATION

- **NOTE: Remove plug from the socket before carrying out any adjustment, servicing or maintenance.**
- Your power tool requires no additional lubrication or maintenance. There are no user serviceable parts in your power tool. Never use water or chemical cleaners to clean your power tool. Wipe clean with a dry cloth. Always store your power tool in a dry place. Keep the motor ventilation slots clean. Keep all working controls free of dust. Occasionally you may see sparks through the ventilation slots, this is normal and will not damage your power tool.
If the supply cord is damaged, it must be replaced by the manufacturer, its service agent or similarly qualified persons in order to avoid a hazard.
- This tool is designed for single or double handed operation (do not overload – let the tool do the work).
Adopt a stable stance and make sure that the mains cable is prevented from coming into contact with the machine or getting caught up on other objects preventing completion of the task being done.
- Ensure that you have removed all foreign objects such as nails and screws from the work piece before commencing sanding.
- For dry sanding only (not to be used for wet sanding).
- Avoid cutting into hidden electrical wiring, pipes or the power lead to this tool. Any cutting of this type may result in electric shock, escape of water and possibly serious injury – always use a residual current device (available separately).
- Contact with a “live” wire will make exposed metal parts of the tool “live” and create an electrical shock risk to the operator.
- Only use accessories that are in good condition. Do not use if they are torn or worn.
- Do not touch any accessory whilst it is still moving.
- Do not treat the surface to be worked with solvent-containing fluids. Materials being heated by the sanding friction can cause toxic vapours to develop.
- Keep your hands away from the cutting area. Do not reach under the material being cut.
- **NOTE:** Instruction that the maximum recommended diameter of mounted wheels, threaded cones and plugs shall not exceed 35mm and that the maximum recommended diameter of sanding accessories shall not exceed 15mm.
- **WARNING:** Do not touch the tip of the accessory after use, it will be very hot and may create a burn risk.
- **NOTE:** The length range of accessories metal pole is 20-25mm.
When the metal pole is completely inserted into collet the maximum allowable overhang length of the metal pole is 25mm.

5.3 CONNECTION TO THE POWER SUPPLY

Make sure the power supply information on the machine’s rating plate are compatible with the power supply you intend to connect it to.

This product comes supplied with a UK standard 3 pin plug fitted. It is designed for connection to a domestic power supply rated at 230V AC.

This appliance is Class III and is designed for connection to a power supply matching that detailed on the rating label and compatible with the plug fitted.

If an extension lead is required, use an approved and compatible lead rated for this appliance. Follow all the instruction supplied with the extension lead.

†Double insulated : This product requires no earth connection as supplementary insulation is applied to the basic insulation to protect against electric shock in the event of failure of the basic insulation.

Apart from replacing the fuse in the plug, no other electrical work is recommended on this machine.

6. TECHNICAL DESCRIPTION

6.1 IDENTIFICATION

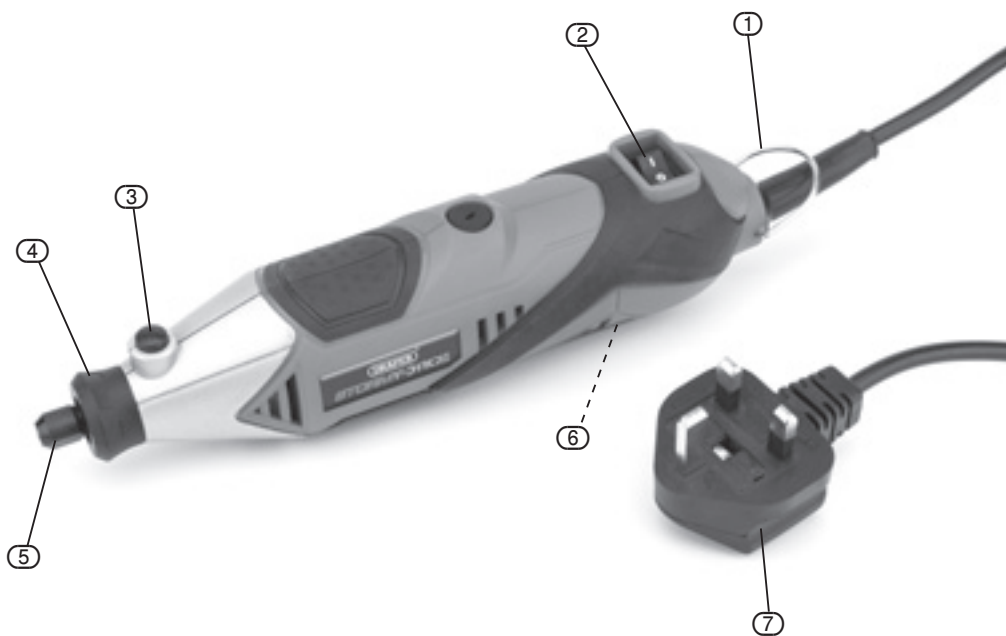

- ① Hook
- ② On/Off Switch
- ③ Spindle Lock
- ④ Collar

- ⑤ Collet nut
- ⑥ Variable Speed Dial
- ⑦ Plug and Cable

7. UNPACKING & CHECKING

7.1 PACKAGING

Carefully remove the multi-tool from the packaging and examine it for any sign of damage that may have happened during shipping. Lay the contents out and check them against the parts shown below. If any part is damaged or missing; please contact the Draper Help Line (the telephone number appears on the Title page) and do not attempt to use the product.

The packaging material should be retained at least during the guarantee period: in case the machine needs to be returned for repair.

Warning! Some of the packaging materials used may be harmful to children. Do not leave any of these materials in the reach of children.

If any of the packaging is to be thrown away, make sure they are disposed of correctly; according to local regulations.

7.2 WHAT'S IN THE BOX?

As well as the multi-tool; there are several parts not fitted or attached to it.

- ⑧ Flexible shaft
- ⑨ Collets x3
- ⑩ Collet spanner/ plain slot screwdriver
- ⑪ Nylon brush x2
- ⑫ Holder for cutting/sanding/grinding discs
- ⑬ Holder for felt polishing wheels
- ⑭ Diamond grinding point x3
- ⑮ Holder for large sanding drum
- ⑯ Holder for small sanding drum
- ⑰ HSS drill bits (2.0, 2.4 & 3.0mm) x3
- ⑱ Brass wheel
- ⑲ Large felt polishing wheel x5
- ⑳ Small felt polishing wheel x5
- ㉑ Cut off wheel (Ø 22mm x 1mm) x25
- ㉒ Fine polishing disc (600 Grit-green) x10

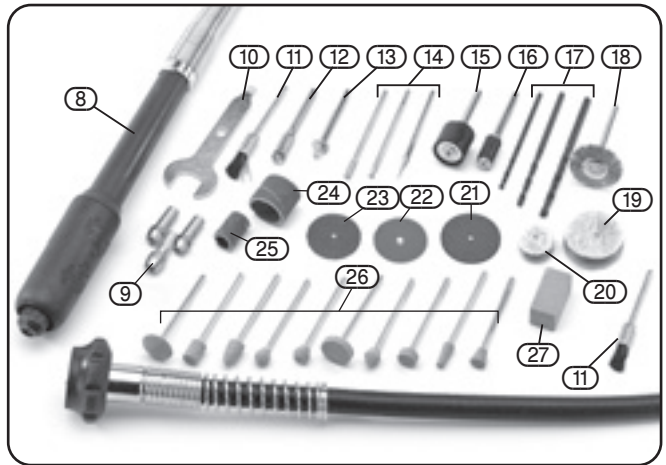

- ㉓ Sanding disc (180 Grit-red) x10
- ㉔ Large sanding drum (120 Grit) x8
- ㉕ Small sanding drum (120 Grit) x8
- ㉖ Aluminium oxide grinding point x10
- ㉗ Sharpening stone

NOTE: To ensure safe use do not use the polishing wheels faster than 25,000rpm:
When you purchase additional accessories check the safe working speed is compatible with the tool.

8. BASIC MULTI-TOOL OPERATIONS

8.1 ACCESSORY INSTALLATION/ REPLACEMENT - FIG. 1

This Multi-Tool is designed for use with 2.0, 2.4 & 3.0mm shank accessories only.

WARNING: Use bits of the correct shank diameter suitable for the speed of the tool.

Selection of the correct accessory, suitable for the intended application is vital. Seek guidance if uncertain of selection.

Press the spindle lock button (3) and unscrew the collet nut (5) using the spanner (10) supplied.

Choose from the collets provided, the appropriate size for the accessory shank. If the size is not known insert the bit into the collet. The collet which offers a machine fit to the shank is the correct one to use. Do not force the bit into the collet.

Place the collet into the spindle before loosely replacing the collet nut (5).

Slide the accessory in as far as possible before tightening the collet nut. Press the spindle lock button (3) and tighten the collet nut with the spanner provided to lock the bit in place. If the accessory seems loose, reduce the collet size to ensure the bit is secured correctly.

NOTE: Do not overtighten the collet nut

8.2 FITTING FLEXIBLE DRIVE SHAFT - FIGS. 2 - 3

Remove collar (4). Depress spindle lock button (3) and remove the collet nut (5). Install the 3.0mm collet and loosely replace the collet nut.

Insert the flexible drive shaft rod (8.2) into the collet chuck and tighten. Screw the drive shaft collar (8.3) onto housing.

8.3 SWITCHING ON AND OFF - FIG. 4

Press switch (2) into the 'I' position. This will start the machine. Press switch to the 'O' position - this will stop the machine.

Using the variable speed dial (6) will enable you to alter the speed of the collet chuck:

Position 1 - SLOW

Position 3 - MEDIUM

Position 6 - FAST

Select the correct speed for the work and type of bit you are using.

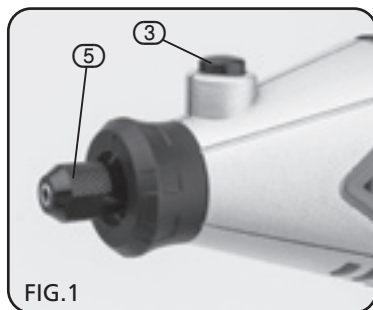

FIG.1

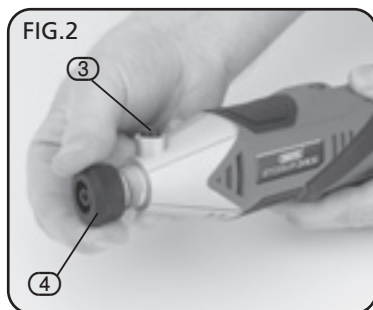

FIG.2

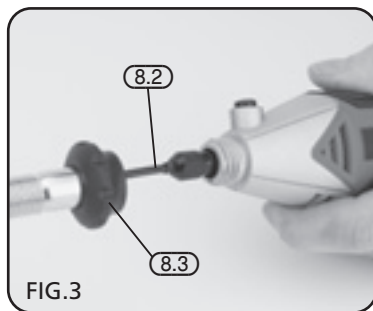

FIG.3

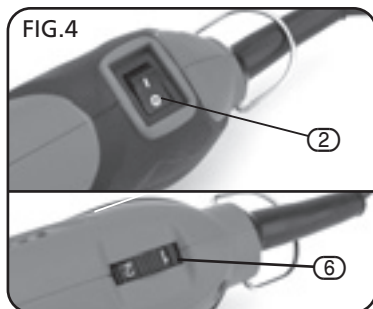

FIG.4

8. BASIC MULTI-TOOL OPERATIONS

8.4 APPLICATIONS

Your multi-tool can be used for drilling, grinding, polishing, milling and brushing. Other jobs like engraving, cutting and removing rust are also possible. It can be used on most wood, metal, glass and ceramics.

It is a good idea to practice on a scrap piece of material. Best results are achieved by an even speed and pressure (not too hard). Use lower speeds for larger tools and higher speeds for smaller tools.

WARNING: Excessive force on this machine will cause the motor to overheat and fail. This is not covered by the guarantee.

8.5 HOLDING THE TOOL - FIGS. 5 - 6

For jobs such as milling or engraving where precision is required, hold the multi-tool like a pen.

Care should be taken not to fully cover exhaust vents. Covering the vents will cause the machine to overheat and fail.

For heavier work like cutting or grinding hold the multi-tool in the palm of your hand.



8.6 FITTING A CUTTING/SANDING DISC - FIG. 7

With the disc holder (12) in the chuck, remove the screw using the plain slot screwdriver (10) (incorporated in the spanner handle tip). Leave one fibre washer on the screw, place the cutting disc on the screw and fit the second fibre washer, refit to the disc holder spindle. (Do not over tighten).

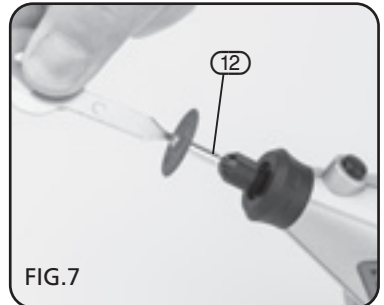

8.7 FITTING THE SANDING DRUMS - FIG. 8

To fit a drum (24), firstly loosen the small screw in the top of the holder (15). This will allow the rubber to relax. Slide the sanding drum onto the holder. To secure simply tighten the screw and the rubber drum will swell, gripping the drum. (Do not over tighten).

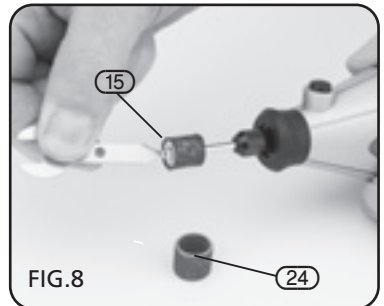

9. MAINTENANCE

9.1 MAINTENANCE & PARTS REPLACEMENT

Regular inspection and cleaning reduces the necessity for maintenance operations and will keep your tool in good working condition.

The motor must be correctly ventilated during tool operation. For this reason avoid blocking the air inlets. After use disconnect the tool from the power supply and vacuum the ventilation slots.

If the replacement of the supply cord is necessary, this has to be done by the manufacturer or his agent in order to avoid a safety hazard.

10. OPTIONAL ACCESSORIES

Stock No.	Part No.	Description	Packed Qty
44479	APT41A	Wire Brush	1
44480	APT42A	Nylon Brush	1
44460	APT43A	Holder for Cutting/Sanding/Grinding Disc	1
44473	APT44A	Holder for Felt Wheels	1
44475	APT46A	Milling Point	1
44476	APT47A	Milling Point	1
44467	APT48A	Diamond Grinding Point	1
44471	APT49A	Diamond Grinding Point	1
44469	APT50A	Diamond Grinding Point	1
44466	APT51A	Diamond Grinding Point	1
44470	APT52A	Diamond Grinding Point	1
63073	APT57	HSS Drill Bit 2.0mm	1
44465	APT59A	Grinding Point 80 Grit	1
44461	APT60A	Grinding Point 80 Grit	1
44462	APT61A	Grinding Point 80 Grit	1
44463	APT62A	Grinding Point 80 Grit	1
44464	APT63A	Grinding Point 80 Grit	1
44456	APT66A	Cutting Disc 120 Grit 0.64mm	30
44472	APT67A	Felt Polishing Wheel 24mmØ	3
44475	APT68A	Cloth Polishing Wheel	1
44454	APT69A	Grinding Wheel 80 Grit	6
44477	APT71A	Brass Wheel	1
44478	APT72A	Bristle Wheel	1
86847	APT94	Sanding Drum 80 Grit (Large)	6
87366	APT102	Sanding Drum 150 Grit (Large)	6
86850	APT95	Holder for Sanding Drums (Large)	1
86851	APT96	1.6mm Collet	1
86852	APT97	2.0mm Collet	1
86853	APT98	2.4mm Collet	1
86854	APT99	3.0mm Collet	1
86855	APT100	3.2mm Collet	1
86856	APT101	Spanner/Plain Slot screwdriver	1

11. EXPLANATION OF SYMBOLS

11.1 EXPLANATION OF SYMBOLS



Warning!
Wear dust mask.



Warning!
Read the instruction manual



Warning!
Wear suitable eye/face
protection.



Warning!
Wear ear defenders.



WEEE
Do not dispose of Waste Electrical
& Electronic Equipment in with
domestic rubbish



Class II construction
(Double insulated).

12. DISPOSAL

12.1 DISPOSAL

- At the end of the machine's working life, or when it can no longer be repaired, ensure that it is disposed of according to national regulations.
- Contact your local authority for details of collection schemes in your area.

In all circumstances:

- Do not dispose of power tools with domestic waste.
- Do not incinerate.
- Do not abandon in the environment.
- Do not dispose of WEEE*
as unsorted municipal waste.



* Waste Electrical & Electronic Equipment.

- **DRAPER TOOLS LIMITED,**
Hursley Road, Chandler's Ford,
Eastleigh, Hampshire. SO53 1YF. U.K.
- **Help Line:** (023) 8049 4344
- **Sales Desk:** (023) 8049 4333
- **General Enquiries:** (023) 8026 6355
- **Service/Warranty Repair Agent**
For aftersales servicing or warranty repairs, please
contact the Draper Tools Help Line for details of an
agent in your local area.

YOUR DRAPER STOCKIST

RDCH0816

