



SPARE PARTS LISTING SHEET FOR 4.0HP Self Propelled Petrol Mower

Stock No.08400 Part No.LMP400

KEY No.	PART No.	STOCK No.	DESCRIPTION
1	Y26809000201	09292	Flat key.
2	Y26400100101	09293	Blade support.
4	Y26300107301	09294	Washer.
5	Y26801106201	09295	Bolt.
6	Y26800104401	09360	Bolt.
7	Y25211800101	09361	Belt wheel protecting cover.
8	Y26300400202	09362	Belt wheel.
9	Y26800300501	09363	Nut.
10	Y25100127301	09364	Belt.
11	Y25100201001	09365	Drive belt wheel.
12	Y26809001701	09366	Spring column pin.
13	Y26801107701	09367	Gear box spring.
14	Y26809000101	09368	Column pin.
15	Y23050102101	09369	16" gear box.
16	Y26800202101	09370	Nut.
17	Y23600105802	09296	7" wheel cover.
18	Y26800502801	09297	Bolt.
19	Y25207900101	09298	Bearing sleeve.
20	Y25207600101	09299	6" wheel.
21	Y26300115501	09300	Front wheel axis assey.
22	Y26300115401	09301	Front wheel axis fixing steel wire.
23	Y23600108901	09371	Deck.
24	Y25202600101	09303	Front wheel axis fixed ring.
25	Y26801102201	09372	Spring.
26	Y26300118901	09305	Flat washer.
27	Y26300115702	09306	Connecting rod.
28	Y25400200303	09307	8" wheel.
29	Y25217800101	09372	Pulling cord protecting cover.
30	Y23600105902	09308	8" wheel cover.
31	Y26900103401	09309	Spring open pin.
32	Y26800606401	09310	Bolt.
33	Y23600103801	09311	Handle left plank.
34	Y26300115801	09312	Long rod.
35	Y26800901301	09313	Bearing clip.
36	Y26801104601	09314	Rear cover board spring.
37	Y25207800101	09315	Rear cover board.
38	Y26800601901	09316	Bolt.
39	Y26800700701	09317	Flat washer.
40	Y26800800201	09318	Spring washer.
41	Y26800501501	09319	Nut.
42	Y26800602501	09373	Bolt.
43	Y26300210601	09321	Square washer.
44	Y60400100201	09322	Engine.

KEY No.	PART No.	STOCK No.	DESCRIPTION
45	Y26300108301	09323	Cord press plate.
46	Y26800301201	09324	Bolt.
47	Y25217700101	09325	Cable clip.
48	Y26300116002	09326	Down handle rod.
49	Y26809002701	09327	Column pin.
50	Y25202800101	09328	Locking handle.
51	Y26300111901	09329	Press plate.
52	Y26300124501	09330	Bolt.
53	Y26800500801	09331	Nut.
54	Y26800603601	09374	Bolt.
55	Y29100101702	09333	Accelerograph handle assey.
56	Y29100104601	09375	Drive pulling cord.
57	Y26800700801	09334	Flat washer.
58	Y26800800301	09335	Spring washer.
59	Y26800501601	09336	Nut.
60	Y26300114201	09376	Flameout rod.
61	Y26300114301	09377	Drive pulling rod.
62	Y26300115902	09338	Upper handle rod.
63	Y29100102801	09339	Frameout pulling cord.
64	Y26800601101	09340	Bolt.
65	Y26300112001	09341	Cable hook.
66	Y25100127101	09342	Grass collection bag.
67	Y26300116101	09343	Grass collection bag plank.
68	Y26300114901	09378	16" rear wheel axis assey.
69	Y25202900101	09348	Handle sleeve.
70	Y26800900201	09379	Washer.
71	Y26900900101	09380	Left output gear.
72	Y26900300201	09381	Right output gear.
73	Y25208000101	09382	8" dustproof wheel cover.
74	Y26800400101	09383	Bearing.
75	Y26900200101	09384	Bearing sleeve.
76	Y26300115002	09385	Handle.
77	Y26800900301	09386	Open washer.
78	Y26300107601	09387	Adjustment washer.
79	Y23600103901	09352	Handle right plank.
80	Y25214200101	09353	Adjustment board.
81	Y26800202001	09354	Bolt.
82	Y26300124401	09356	Wheel axis fixed ring.
83	Y26800502401	09357	Nut.
84	Y25231800101	09388	Blade support sleeve.
85	Y26800201901	08355	Bolt.
86	Y26300107801	09358	Spanner.
87	Y26300107901	09359	Spanner rod.

Helpline: (023) 8049 4344. Sales Desk: (023) 8049 4333. General Enquiries: (023) 8026 6355.



SPARE PARTS DRAWING SHEET FOR

4.0HP Self Propelled Petrol Mower

Stock No.08400 Part No.LMP400

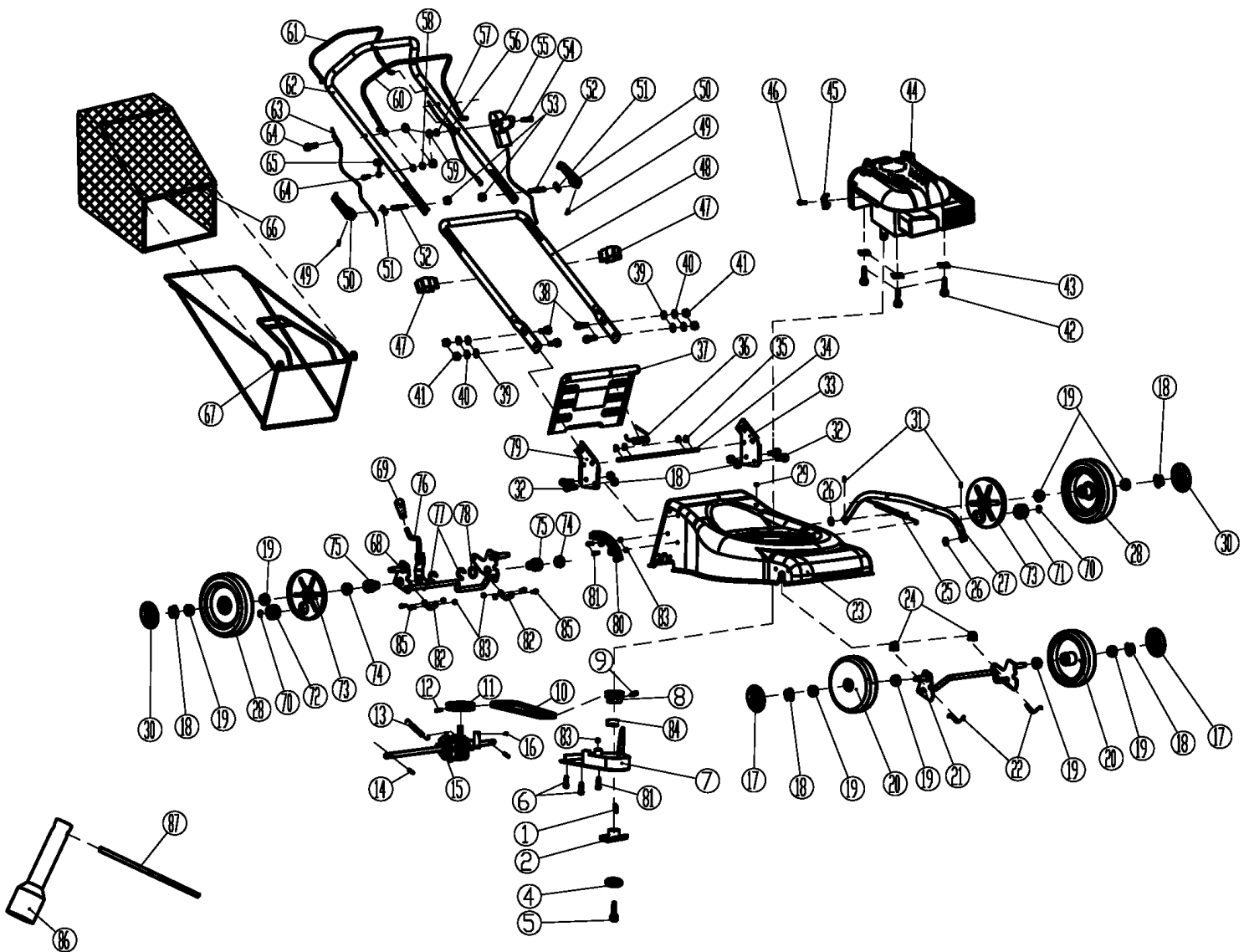

Helpline: (023) 8049 4344. Sales Desk: (023) 8049 4333. General Enquiries: (023) 8026 6355.

DRAPER TOOLS LTD, HURSLEY ROAD, CHANDLER'S FORD, EASTLEIGH, HANTS. SO53 1YF. U.K. internet: www.draper.co.uk e-mail: sales@drapertools.com

RWDH140409



SPARE PARTS LISTING & DRAWING SHEET FOR 4.0HP Self Propelled Petrol Mower

Stock No.08400 Part No.LMP400

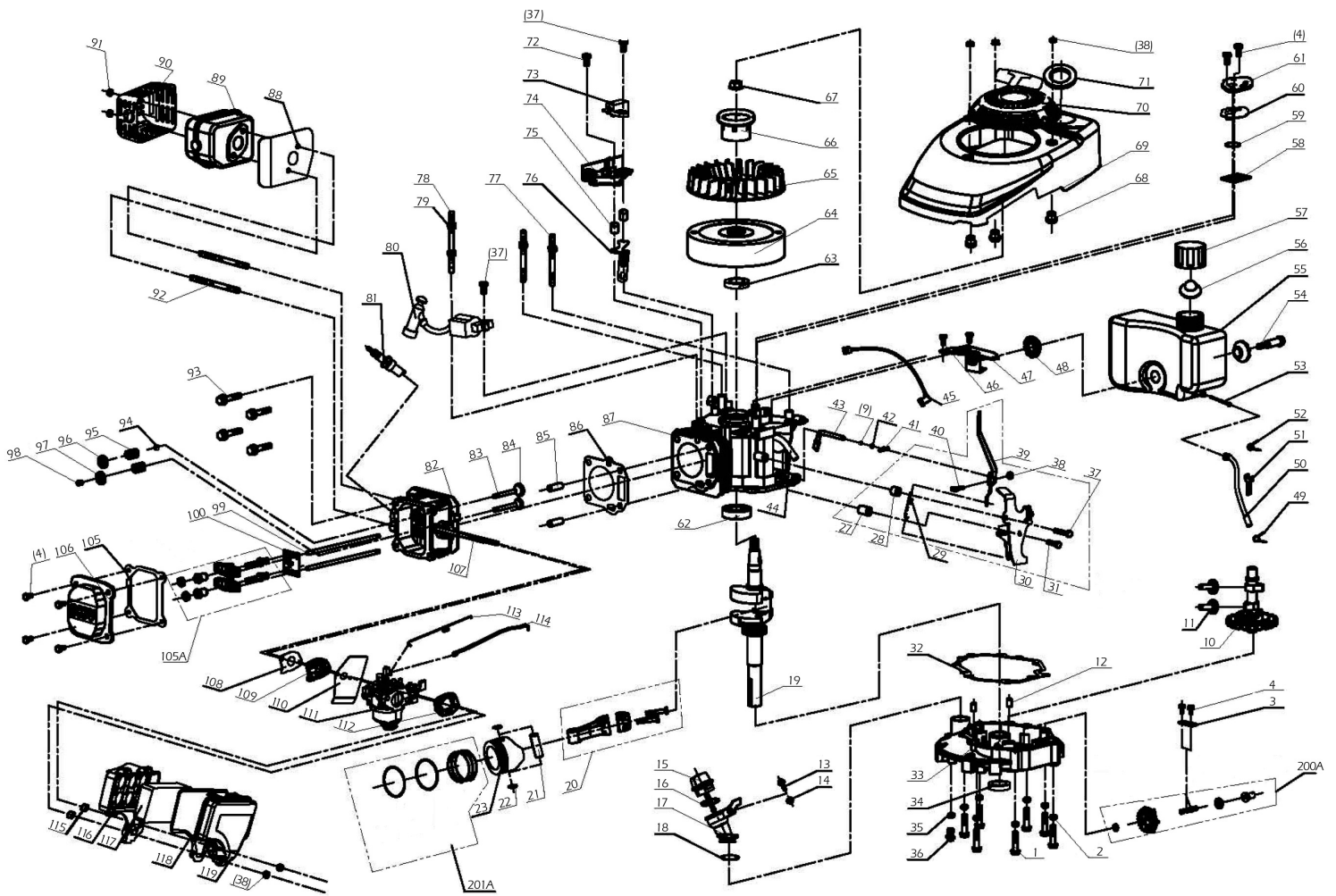

KEY No.	PART No.	STOCK No.	DESCRIPTION
1	YGP-26800607601	05807	Bolt M6 *30.
2	YGP-26800702501	05803	Wave washer ø6.
3	YGP-26300210102	05809	Dual hole press plate.
4	YGP-26800604101	05810	Bolt M6 *12.
10	YGP-23055000401	05817	Nylon protuberant shaft assy.
11	YGP-26900102301	05818	Column.
12	YGP-26809001601	05819	Position fixed pin.
13	YGP-26800608801	05820	Bolt M5 x 20.
14	YGP-26800503501	05821	Nut M5.
15	YGP-25100121002	05823	Oil adding gauge.
16	YGP-25100123302	05824	O type ring 25 *3.1.
17	YGP-25100121102	05825	Oil adding pipe.
18	YGP-25100123202	05826	O type ring 20 *2.4.

KEY No.	PART No.	STOCK No.	DESCRIPTION
19	YGP-23053000601	05827	Crank assy.
20	YGP-23054000301	05828	Link rod assy.
21	YGP-26900102201	05829	Piston pin.
22	YGP-26900102101	05831	Piston pin clip spring.
23	YGP-26400100601	05832	Piston.
27	YGP-26900103201	05836	Sheath 1.
28	YGP-26900103301	05837	Sheath 2.
29	YGP-26801102601	05838	Speed adjustment spring.
30	YGP-23057000802	05839	One way speed adjust. assy.
31	YGP-26800608701	05840	Flange bolt M6 *32.
32	YGP-25600100401	05841	Box sealing washer.
33	YGP-26400104002	05842	Cylinder head cover.
34	YGP-25100123602	05843	Oil sealing FB25*38*7.

Helpline: (023) 8049 4344. Sales Desk: (023) 8049 4333. General Enquiries: (023) 8026 6355.

DRAPER TOOLS LTD, HURSLEY ROAD, CHANDLER'S FORD, EASTLEIGH, HANTS. SO53 1YE U.K. internet: www.draper.co.uk e-mail: sales@drapertools.com

KCLJ030511



SPARE PARTS LISTING SHEET FOR 4.0HP Self Propelled Petrol Mower

Stock No.08400 Part No.LMP400

KEY No.	PART No.	STOCK No.	DESCRIPTION
35	YGP-26300205701	05844	Oil outlet washer.
36	YGP-26300205601	05845	Oil outlet screw plug.
37	YGP26800607801	05846	Flange bolt M6 *25.
38	YGP26800501901	05847	Flange nut M6.
39	YGP23057000901	05848	Speed adjustment rocker.
40	YGP26800301101	05849	Speed adjustment screw.
41	YGP-26900103401	05850	Spring open pin.
42	YGP-25100123501	05851	Oil sealing FB6 *11*4.
43	YGP-26900103001	05852	Adjusting rod.
44	YGP-25100123001	05853	Aerating pipe.
45	YGP-23058000402	05854	Frameout assy.
46	YGP-26800608001	05855	Bolt M6 *16.
47	YGP-23063000301	05857	Gasoline tank bracket.
48	YGP-25100123101	05858	Damping washer.
49	YGP-26900102701	05859	Oil pipe clip B.
50	YGP-25100124001	05860	Oil inner pipe.
51	YGP-26300206401	05861	Oil pipe clip.
52	YGP-26900102601	05862	Oil pipe clip A.
53	YGP-25100125802	05863	Oil burning filter net.
54	YGP-26800605301	05865	Gasoline tank bolt.
55	YGP-25100120901	05866	Oil tank.
56	YGP-25100124501	05867	Oil tank sealing washer.
57	YGP-25100122702	05868	Oil cover.
58	YGP-26900102001	05869	Filter net.
59	YGP-25100112601	05870	Breathing valve plate.
60	YGP-25100123901	05871	Breathing sealing washer.
61	YGP-23052000501	05873	Breathing cover assy.
62	YGP-26800400201	05874	Rolling bearing 6205 E grade.
63	YGP-25100123402	05875	Oil sealing FB22 *35*7.
64	YGP-23061000301	05876	Cast iron flying wheel.
65	YGP-25100121901	05877	Fan.
66	YGP-26900103701	05878	Passive tray.
67	YGP-26800502701	05879	Nut M14 *1.5.
68	YGP-26900103601	05881	Starting shell sheath.
69	YGP-25100117303	05882	Starting shell.
70	YGP-23062000502	05883	Starter assy.
71	YGP-25100126301	05884	Starting shell sealing washer.
72	YGP-26800608301	05885	Flange bolt M6 x 20.
73	YGP-23058000202	05886	Frameout switch assy.
74	YGP-23058000601	05887	Brake controller assy.
75	YGP-26800703001	05888	Washer sheath.
76	YGP-26300211802	05889	Oil adding pipe bracket.

KEY No.	PART No.	STOCK No.	DESCRIPTION
77	YGP-26800603901	05890	Dual head bolt B.
78	YGP-26800603801	05891	Dual head bolt A.
79	YGP-26800502201	05892	Screw M6.
80	YGP-23062000201	05893	Ignition assy.
81	YGP-23062000301	05896	Spark F7RTC.
82	YGP-26400100401	05897	Cylinder head.
83	YGP-26300206001	05899	Air inlet.
84	YGP-26300206101	05906	Air outlet.
85	YGP-26809001501	05913	Position fixed pin.
86	YGP-25600100201	05917	Cylinder head sealing washer.
87	YGP-23052002001	05924	Cylinder.
88	YGP-25600100101	05950	Muffler washer.
89	YGP-23060000901	05968	Air discharge and muffler assy.
90	YGP-23060000801	05969	Muffler sheath assy.
91	YGP-26800502401	05970	Flange self-locking nut M6.
92	YGP-26800609901	05971	Nut screw M6 *92.
93	YGP-26800605001	05972	Flange nut M8 *45.
94	YGP-26300207401	05973	Oil block sheath.
95	YGP-26801103101	05974	Air spring.
96	YGP-26900102401	05975	Air inlet spring seat.
97	YGP-26900102501	05976	Air outlet spring seat.
98	YGP-26400100801	05977	Top cat.
99	YGP-23055000501	05978	Pushing rod assy.
100	YGP-26300206301	05979	Pushing rod guidebar.
105	YGP-25100123701	05984	Cylinder head cover sealing washer.
105A	YGP-23054000801	05811	Rocker assembly.
106	YGP-26300207001	05985	Cylinder cover.
107	YGP-26800605502	05986	Carburetor bolt.
108	YGP-25100122901	05987	Cylinder head & air inlet pipe.
109	YGP-25100121201	05988	Air inlet pipe.
110	YGP-25100124201	05989	Air inlet pipe & carburetor seal.
111	YGP-23056000802	05990	Carburetor assy.
112	YGP-25600100301	05991	Air filler sealing washer.
113	YGP-26801102901	05992	Accelerograph spring.
114	YGP-26900102801	05993	Valve rod.
115	YGP-26900103501	05994	Air filter sheath.
116	YGP-25100117101	05995	Air filter base.
117	YGP-25100124301	05996	Air filter core.
118	YGP-25600101101	05997	Air filter shell sealing washer.
119	YGP-25100121801	05998	Air filter upper cover.
200A	YGP-23057000401	05999	Speed adjusting gear assy.
201A	YGP-23054000801	06000	Piston ring assy.

Helpline: (023) 8049 4344. Sales Desk: (023) 8049 4333. General Enquiries: (023) 8026 6355.

DRAPER TOOLS LTD, HURSLEY ROAD, CHANDLER'S FORD, EASTLEIGH, HANTS. SO53 1YF. U.K. internet: www.draper.co.uk e-mail: sales@drapertools.com