

DRAPER[®]

INSTRUCTIONS FOR

M Class 230V 35L Wet & Dry Vacuum Cleaner

Stock No.38015 Part No.WDV35LMC

IMPORTANT: PLEASE READ THESE INSTRUCTIONS CAREFULLY TO ENSURE THE SAFE AND EFFECTIVE USE OF THIS PRODUCT.



CE

DRAPER[®]

GENERAL INFORMATION

These instructions accompanying the product are the original instructions. This document is part of the product, keep it for the life of the product passing it on to any subsequent holder of the product. Read all these instructions before assembling, operating or maintaining this product.

This manual has been compiled by Draper Tools describing the purpose for which the product has been designed, and contains all the necessary information to ensure its correct and safe use. By following all the general safety instructions contained in this manual, it will ensure both product and operator safety, together with longer life of the product itself.

All photographs and drawings in this manual are supplied by Draper Tools to help illustrate the operation of the product.

Whilst every effort has been made to ensure the accuracy of information contained in this manual, the Draper Tools policy of continuous improvement determines the right to make modifications without prior warning.

1. TITLE PAGE

1.1 INTRODUCTION:

USER MANUAL FOR:

1200W 230V 35L

WET & DRY VACUUM CLEANER

Stock no. 38015

Part no. WDV35LMC

1.2 REVISIONS:

Date first published April 2015

As our user manuals are continually updated, users should make sure that they use the very latest version.

Downloads are available from: <http://www.drapertools.com/b2c/b2cmanuals.pgm>

DRAPER TOOLS LIMITED

HURSLEY ROAD

CHANDLER'S FORD

EASTLEIGH

HAMPSHIRE

SO53 1YF UK

WEBSITE: www.drapertools.com

PRODUCT HELPLINE: +44 (0) 23 8049 4344

GENERAL FAX: +44 (0) 23 8026 0784

1.3 UNDERSTANDING THIS MANUALS SAFETY CONTENT:

WARNING! Information that draws attention to the risk of injury or death.

CAUTION! Information that draws attention to the risk of damage to the product or surroundings.

1.4 COPYRIGHT © NOTICE:

Copyright © Draper Tools Limited.

Permission is granted to reproduce this publication for personal & educational use only.

Commercial copying, redistribution, hiring or lending is prohibited.

No part of this publication may be stored in a retrieval system or transmitted in any other form or means without written permission from Draper Tools Limited.

In all cases this copyright notice must remain intact.

2. CONTENTS

2.1 CONTENTS

	<i>Page content</i>	<i>Page</i>
1	TITLE PAGE	
	1.1 INTRODUCTION	2
	1.2 REVISION HISTORY	2
	1.3 UNDERSTANDING THIS MANUAL	2
	1.4 COPYRIGHT NOTICE	2
2	CONTENTS	
	2.1 CONTENTS	3
3	GUARANTEE	
	3.1 GUARANTEE	4
4	INTRODUCTION	
	4.1 SCOPE	5
	4.2 SPECIFICATION	5
	4.3 HANDLING & STORAGE	5
5	HEALTH & SAFETY INFORMATION	
	5.1 GENERAL SAFETY INSTRUCTIONS	6
	5.2 GENERAL SAFETY INSTRUCTIONS FOR THIS VACUUM CLEANER	8
6	TECHNICAL DESCRIPTION	
	6.1 IDENTIFICATION	10B
7	UNPACKING & CHECKING	
	7.1 PACKAGING	10A
8	PREPARING THE VACUUM CLEANER.....	11
	8.1 RELEASING THE MOTOR UNIT.....	11
	8.2 USING THE CORD HOOK.....	12
	8.3 USING AS A WET AND DRY VACUUM CLEANER.....	12
	8.4 USING THE VACUUM WITH THE POWER TOOLS SOCKET.....	13
	8.5 SELF CLEANING FILTER FUNCTION	13
	8.6 CONNECTING A POWER TOOL TO THE VACUUM CLEANER.....	14
	8.7 INSERTING THE PAPER DUST BAG.....	14
	8.8 INSERTING THE CARTRIDGE FILTER.....	15
	8.9 INSERTING THE FOAM FILTER.....	15
	8.10 ATTACHING THE FLEXIBLE HOSE	15
	8.11 FITTING THE EXTENSION TUBES & FLOOR HEAD ATTACHMENT	16
9	OPERATION AND USE	
	9.1 FOR USE AS A DRY VACUUM CLEANER.....	17
	9.2 FOR USE AS A WET VACUUM CLEANER	17
	9.3 TO VACUUM LARGE QUANTITIES OF LIQUID.....	17
	9.4 USING THE VACUUM CLEANER WITH A POWER TOOL	18
10	MAINTENANCE	
	10.1 CHANGING THE DUSTBAG.....	20
	10.2 CLEANING THE FOAM FILTER.....	20
	10.3 CLEANING THE CARTRIDGE FILTER	21
	10.4 CLEANING THE DRUM.....	22
	10.5 REPLACING THE POWER CORD	22
11	TROUBLESHOOTING.....	23
12	EXPLANATION OF SYMBOLS	24
13	DISPOSAL	25
	13.1 DISPOSAL	25
	DECLARATION OF CONFORMITY	ENCLOSED

3. GUARANTEE

3.1 GUARANTEE

Draper tools have been carefully tested and inspected before shipment and are guaranteed to be free from defective materials and workmanship.

Should the tool develop a fault, please return the complete tool to your nearest distributor or contact Draper Tools Limited, Chandler's Ford, Eastleigh, Hampshire, SO53 1YF. England. Telephone Sales Desk: (023) 8049 4333 or Product Helpline (023) 8049 4344.

A proof of purchase must be provided with the tool.

If upon inspection it is found that the fault occurring is due to defective materials or workmanship, repairs will be carried out free of charge. This guarantee period covering parts/labour is 12 months from the date of purchase except where tools are hired out when the guarantee period is ninety days from the date of purchase. The guarantee is extended to 24 months for parts only. This guarantee does not apply to normal wear and tear, nor does it cover any damage caused by misuse, careless or unsafe handling, alterations, accidents, or repairs attempted or made by any personnel other than the authorised Draper warranty repair agent.

Note: If the tool is found not to be within the terms of warranty, repairs and carriage charges will be quoted and made accordingly.

This guarantee applies in lieu of any other guarantee expressed or implied and variations of its terms are not authorised.

Your Draper guarantee is not effective unless you can produce upon request a dated receipt or invoice to verify your proof of purchase within the guarantee period.

Please note that this guarantee is an additional benefit and does not affect your statutory rights.

Draper Tools Limited.

4. INTRODUCTION

4.1 SCOPE

This wet and dry vacuum cleaner has a high-efficiency by pass motor and 230V power tool outlet socket, ideally suited for connection to power tools fitted with dust extraction capabilities, providing filtration of the finest particles in line with 'M' class approved standards .

ATTENTION: any other application is considered misuse.

4.2 SPECIFICATION

Stock no	38015
Part no	WDV35LMC
Rated voltage	230V~50Hz
Rated input.....	1200W
Tank volume	35L
Vacuum pressure	24Kpa (240 mbar)
Max. airflow	60L/sec
Sound pressure level	<75db(A)
Weight (excluding accessories).....	8.5kg

4.3 HANDLING AND STORAGE

Take care when using this product.

- Take care when handling and lifting. Do not drop this machine.
- If any part is worn or damaged, do not use.
- Do not use the machine in wet or damp conditions.
- Keep away from children.

5. HEALTH & SAFETY INFORMATION

5.1 GENERAL SAFETY INSTRUCTIONS

General Power Tools Safety Warnings

WARNING: Read all instructions. Failure to follow all instructions listed below may result in electric shock, fire and/or serious injury. Save all warnings and instructions for future reference.

The term “power tool” in the warnings refers to your mains operated (corded) power tool or battery operated (cordless) power tool.

1) Work area safety

- a) **Keep work area clean and well lit.** Cluttered or dark areas invite accidents.
- b) **Do not operate power tools in explosive atmospheres, such as in the presence of flammable liquids, gases or dust.** Power tools create sparks which may ignite the dust or fumes.
- c) Keep children and bystanders away while operating a power tool. Distractions can cause you to lose control.

2) Electrical safety

- a) **Power tool plugs must match the outlet.** Never modify the plug in any way. Do not use any adapter plugs with earthed (grounded) power tools. Unmodified plugs and matching outlets will reduce risk of electrical shock.
- b) **Avoid body contact with earthed or grounded surfaces such as pipes, radiators, ranges and refrigerators.** There is an increased risk of electric shock if your body is earthed or grounded.
- c) **Do not expose power tools to rain or wet conditions.** Water entering a power tool will increase the risk of electric shock.
- d) **Do not abuse the cord. Never use the cord for carrying, pulling or unplugging the power tool.** Keep cord away from heat, oil, sharp edges or moving parts. Damaged or entangled cords increase the risk of electric shock.
- e) **When operating a power tool outdoors, use an extension cord suitable for outdoor use.** Use of a cord suitable for outdoor use reduces the risk of electric shock.
- f) **If operating a power tool in a damp location is unavoidable, use a residual current device (RCD) protected supply.** Use of an RCD reduces the risk of electric shock.

3) Personal safety

- a) **Stay alert, watch what you are doing and use common sense when operating a power tool. Do not use a power tool while you are tired or under the influence of drugs, alcohol or medication.** A moment of inattention while operating power tools may result in serious personal injury.
- b) **Use personal protective equipment. Always wear eye protection.** Protective equipment such as dust mask, non-skid safety shoes, hard hat, or hearing protection used for appropriate conditions will reduce personal injuries.
- c) **Prevent unintentional starting. Ensure the switch is in the off position before connecting to power source and/or battery pack, picking up or carrying the tool.** Carrying power tools with your finger on the switch or energising power tools that have the switch on invites accidents.
- d) **Remove any adjusting key or wrench before turning the power tool on.** A wrench or a key left attached to a rotating part of the power tool may result in personal injury.

5. HEALTH & SAFETY INFORMATION

- e) **Do not overreach. Keep proper footing and balance at all times.** This enables better control of the power tool in unexpected situations.
 - f) **Dress properly. Do not wear loose clothing or jewellery. Keep your hair, clothing and gloves away from moving parts.** Loose clothes, jewellery or long hair can be caught in moving parts.
 - g) **If devices are provided for the connection of dust extraction and collection facilities, ensure these are connected and properly used.** Use of dust collection can reduce dust related hazards.
- 4) **Power tool use and care**
- a) **Do not force the power tool. Use the correct power tool for your application.** The correct power tool will do the job better and safer at the rate for which it was designed.
 - b) **Do not use the power tool if the switch does not turn it on and off.** Any power tool that cannot be controlled with the switch is dangerous and must be repaired.
 - c) **Disconnect the plug from the power source and/or the battery pack from the power tool before making any adjustments, changing accessories, or storing power tools.** Such preventive safety measures reduce the risk of starting the power tool accidentally.
 - d) **Store idle power tools out of the reach of children and do not allow persons unfamiliar with the power tool or these instructions to operate the power tool.** Power tools are dangerous in the hands of untrained users.
 - e) **Maintain power tools. Check for misalignment or binding of moving parts, breakage of parts and any other condition that may affect the power tools operation. If damaged, have the power tool repaired before use.** Many accidents are caused by poorly maintained power tools.
 - f) **Keep cutting tools sharp and clean.** Properly maintained cutting tools with sharp cutting edges are less likely to bind and are easier to control.
 - g) Use the power tool, accessories and tool bits etc., in accordance with these **instructions, taking into account the working conditions and the work to be performed.** Use of the power tool for operations different from intended could result in a hazardous situation.
- 5) **Battery tool use and care**
- a) **Recharge only with the charger specified by the manufacturer.** A charger that is suitable for one type of battery pack may create a risk of fire when used with another battery pack.
 - b) **Use power tools only with specifically designated battery packs.** Use of any other battery packs may create a risk of injury and fire.
 - c) **When battery pack is not in use, keep it away from other metal objects, like paper clips, coins, keys, nails, screws or other small metal objects, that can make a connection from one terminal to another.** Shorting the battery terminals together may cause burns or a fire.
 - d) **Under abusive conditions, liquid may be ejected from the battery; avoid contact.** If contact accidentally occurs, flush with water. If liquid contacts eyes, additionally seek medical help. Liquid ejected from the battery may cause irritation or burns.
 - 6) **Service**
 - a) **Have your power tool serviced by a qualified repair person using only identical replacement parts.** This will ensure that the safety of the power tool is maintained.

5. HEALTH & SAFETY INFORMATION

5.2 GENERAL SAFETY INSTRUCTIONS FOR THIS VACUUM CLEANER

- Please save this manual for future reference.
- Electrical appliances are not toys. Use and store the vacuum out of reach of children.
- This appliance is not designed for use by people (including children) with limited physical, sensorial or mental capacity or anyone who has not read this instruction manual.
- All packaging, plastic bags, PSE pods, etc. must be kept out of reach of children.
- This appliance has been designed to operate only with alternating current. Before use, always check the power supply corresponds to the voltage on the rating plate.
- **ONLY plug this appliance into power sockets with a minimum rating of 10A.**
- **Do not remove the plug from the socket by pulling on the power cord.**
- Do not turn on the "Self Cleaning Filter" function manually for more than 30 seconds without letting the mechanism cool for at least 15 seconds.
- Make sure that the power supply is equipped with a differential circuit-breaker.
- Unwind the power cord completely before turning on the appliance.
- Only use an extension cord in perfect condition; make sure that the section is suitable for the power of the appliance added to the power of the electric tool.
- Do not pull the power cord around sharp edges and avoid pinching or crushing it.
- Never leave the appliance running unattended.
- Never leave the appliance where it could be damaged by the weather (rain, cold, sun, etc.).
- Never use the appliance:
 - with damp hands;
 - if it has been dropped, is visibly damaged, or does not seem to be working correctly;
 - if the power plug or cord are defective.
- **ALWAYS unplug the appliance immediately after use and before cleaning or servicing it in any way.**
- Repairs, if necessary, should be carried out only by qualified professionals using original spare parts from the manufacturer.

ATTEMPTING TO REPAIR THE APPLIANCE YOURSELF CAN BE EXTREMELY DANGEROUS!

- In compliance with current regulations, end-of-life appliances must be rendered useless by cutting off the power cord before disposal.
- Do not use the appliance to vacuum flammable, explosive, or corrosive substances.
- Do not use the appliance in environments filled with fumes.
- Use only water to clean the appliance. Do not use trichloroethylene, solvents, or abrasive detergents.

CLASS M PERFORMANCE IS ONLY POSSIBLE WHEN USING THE CORRECT BAGS AND FILTER CARTRIDGES. ANY OTHER BAGS OR FILTERS COULD COMPROMISE PERFORMANCE AND POSSIBLY ENDANGER YOUR HEALTH.

THE MANUFACTURER WILL ACCEPT NO RESPONSIBILITY FOR DAMAGE THAT MAY OCCUR DUE TO IMPROPER USE, FAILURE TO FOLLOW THE INSTRUCTIONS IN THIS MANUAL, MODIFICATIONS, OR POOR MAINTENANCE!

6. TECHNICAL DESCRIPTION

6.1 IDENTIFICATION



- ① Power tool outlet socket.
- ② Head and tank assembly fixing locks.
- ③ Hose inlet.
- ④ Tank.
- ⑤ Flexible hose.
- ⑥ Extension tubes (x2).
- ⑦ Floor cleaning attachment.
- ⑧ Liquid floor cleaning head insert.
- ⑨ Brush floor cleaning head insert.
- ⑩ Crevice nozzle.
- ⑪ Power tool exhaust connection stepped adaptor.
- ⑫ Foam filter (liquid suction).
- ⑬ Cartridge filter (dry suction).
- ⑭ Paper dust bag (one only).
- ⑮ Power cord hook.
- ⑯ Motor head unit.

7. UNPACKING & CHECKING

7.1 PACKAGING

Carefully remove the product from the packaging and examine it for any sign of damage that may have happened during shipping. Lay the contents out and check them against the parts shown below. If any part is damaged or missing; please contact the Draper Helpline (the telephone number appears on the Title page) and do not attempt to use the product.

The packaging material should be retained at least during the guarantee period: in case the machine needs to be returned for repair.

Warning! Some of the packaging materials used may be harmful to children. Do not leave any of these materials in the reach of children.

If any of the packaging is to be thrown away, make sure they are disposed of correctly; according to local regulations.

8. PREPARING THE VACUUM CLEANER

8.1 RELEASING THE MOTOR UNIT (FIGS.1 – 4):

- To release the motor unit, lift the head and tank assembly fixing locks (2) in an upward direction (fig.1).

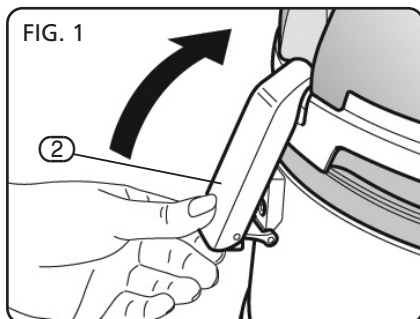

- Pull away the hooked ends of the locks to free the head unit from the tank (fig.2).

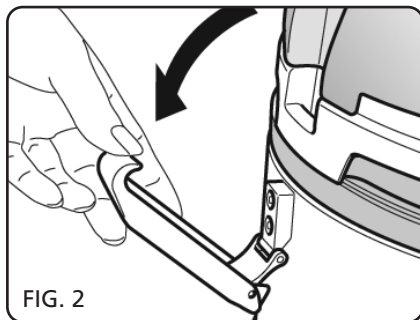

- To lock the head unit to the tank, place the hooked ends of the locks into the recessed sections of the head unit.

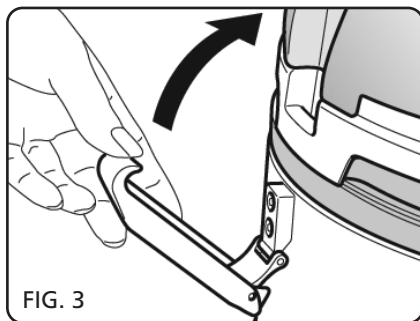

- Press downwards on the locks to secure.

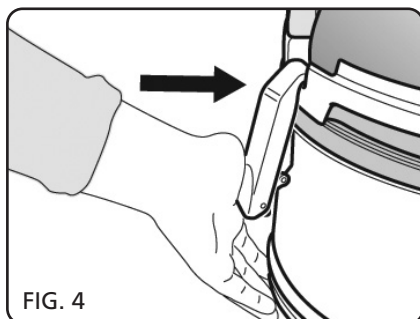

8. PREPARING THE VACUUM CLEANER

8.2 USING THE CORD HOOK (FIG.5):

The appliance is fitted with a built in cord hook (15) to aid safe operation and useful storage.

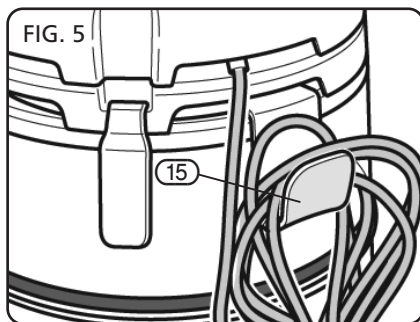

8.3 USING AS A WET AND DRY VACUUM CLEANER (FIG.6):

For use as a wet and dry vacuum cleaner:

Selector switch (A): in "MANUAL" position (🗑️).

- Power switch (B):
- Position ① – appliance OFF (indicator light (C) off).
 - Position ② – appliance ON (indicator light (C) on).

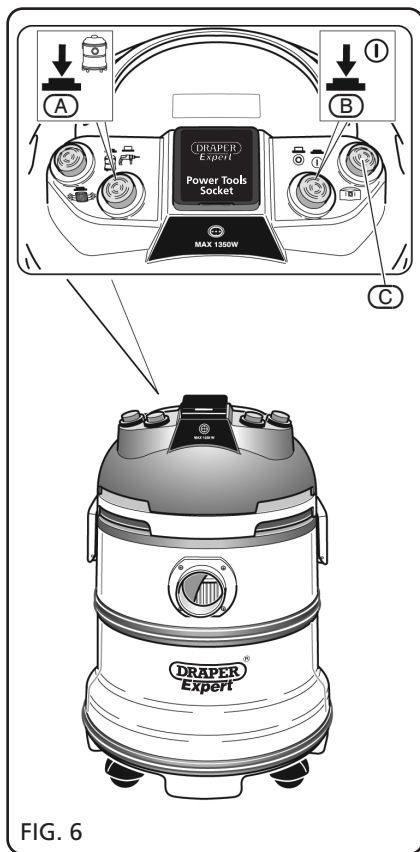

8. PREPARING THE VACUUM CLEANER

8.4 USING THE VACUUM WITH THE POWER TOOLS SOCKET (FIG.7):

Using the vacuum in conjunction with the power tools socket:

Selector switch (A): in "AUTOMATIC" position (🔧).

Power switch (B):

- Position (I) – appliance ON (indicator light (C) on).

The appliance runs in synch with the power tool.

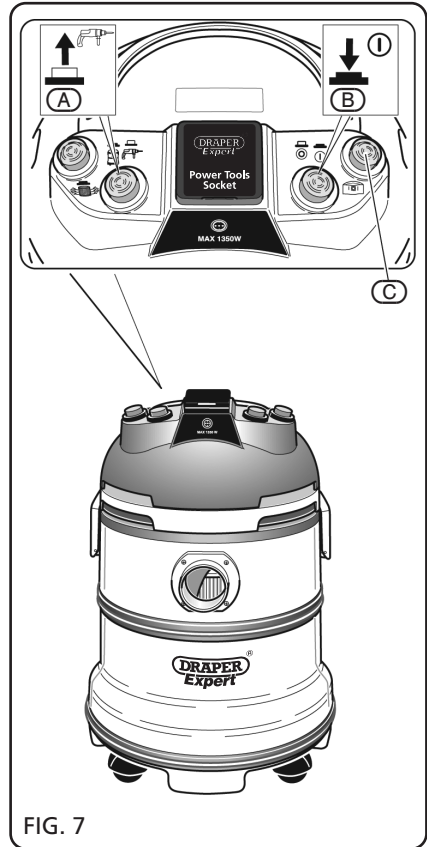

FIG. 7

8.5 SELF-CLEANING FILTER FUNCTION (FIG.8):

With switch (B) in position (I), when switch (A) is set to "AUTOMATIC" position (🔧) the self-cleaning filter function is activated.

- When the appliance is switched off, it will continue to run for 8/10 seconds, then the self-cleaning filter function will begin.
- To start the self-cleaning filter function manually, press the orange switch (🗑️) (D).

Important: When switch (B) is in position (⊙), the self-cleaning filter function is disabled.

Do not operate the self clean function manually for more than 30 seconds without allowing 15 seconds cool down time.

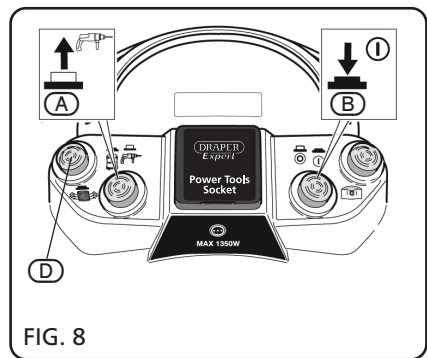
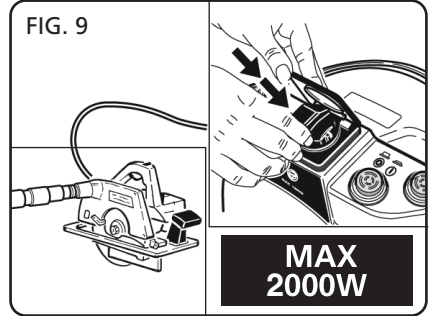

FIG. 8

8. PREPARING THE VACUUM CLEANER

8.6 CONNECTING A POWER TOOL TO THE VACUUM CLEANER (FIGS.9 – 10):

- Plug the power tool into the socket on the motor unit (fig.9).



- Plug the vacuum into the power supply (fig10).
- **Important:** The plug is designed for power tools with a maximum rating of 2000W.

Warning: NEVER plug in power tools with a higher rating.

Warning: NEVER plug more than one power tool into the socket on the motor unit.

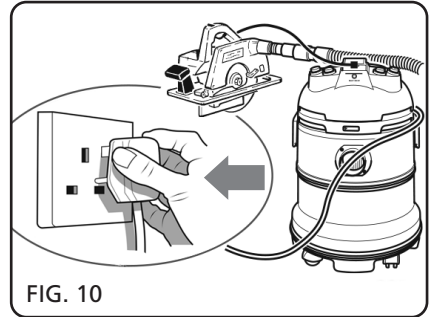

8.7 INSERTING THE PAPER DUST BAG (FIGS.11 – 12):

Warning! Use the dust bag (14) only when the filter cartridge is installed.

- Insert the paper filter bag in the waste drum.

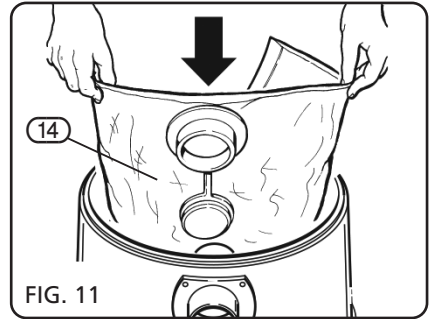

- Fit the plastic flange (14.1) onto the air inlet connector (3).
Be careful not to damage the bag.

- Use the bag to remove dirt more hygienically.

Warning! Avoid using the bag for damp materials.

Change the bag when vacuumed material fills approximately three quarters of its capacity. The bag must not be reused, always replace the used bag with a new one. Always keep a spare pack of dust bags handy.

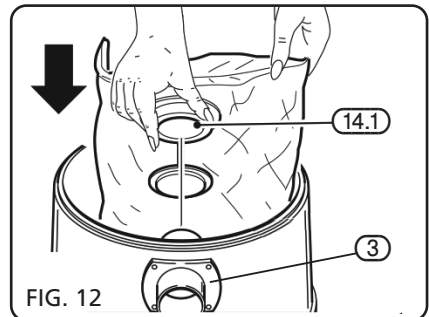

8. PREPARING THE VACUUM CLEANER

8.8 INSERTING THE CARTRIDGE FILTER (FIGS.13 – 14):

- Place the filter (13) on the motor housing (16).

Important: This tool must not be used for dry-dusty materials or for on-tool extraction without the dust bag and filter fitted. Class M performance is only achieved through use of both filter and bag together.

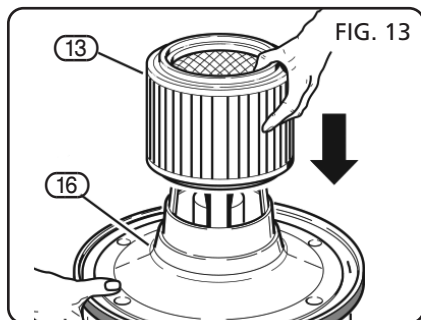

- Fit the plastic disc (13.1) onto the filter.

Important: Avoid using the filter for damp materials.

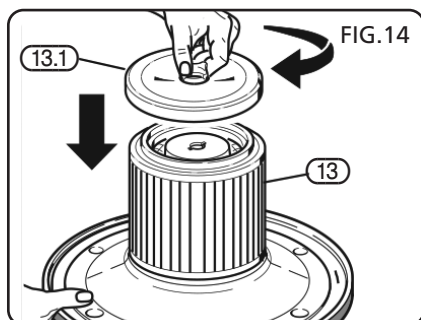

8.9 INSERTING THE FOAM FILTER (FIG.15):

Important: To vacuum liquids, **ALWAYS** use the foam filter (12).

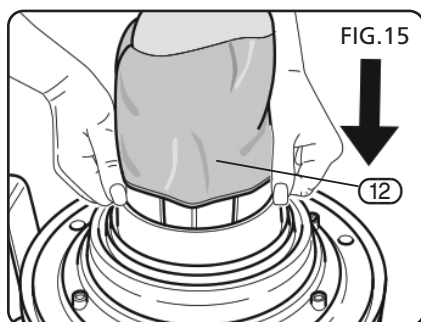

8.10 ATTACHING THE FLEXIBLE HOSE (FIG.16):

- Attach the connector of the flexible hose (5.2) to the air inlet connector (3).

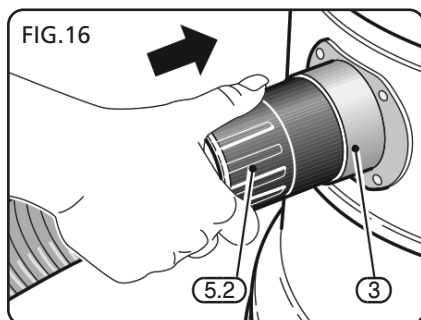

8. PREPARING THE VACUUM CLEANER

8.11 FITTING THE EXTENSION TUBES & FLOOR HEAD ATTACHMENT (FIGS.17 – 19):

- Attach the extension tubes (6) as required.

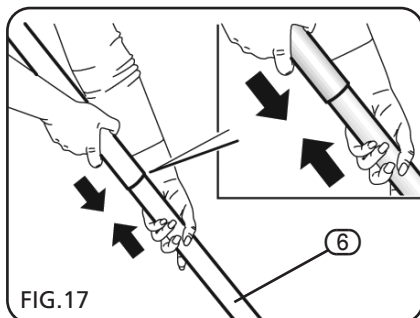

FIG.17

- Connect to the floor head attachment (7).

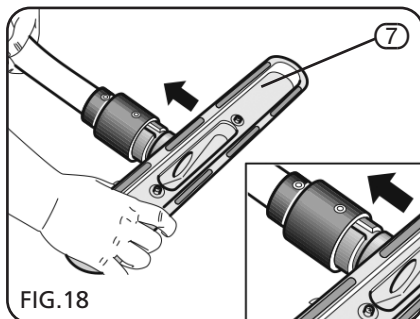

FIG.18

- Rotate the floor head attachment 180°.

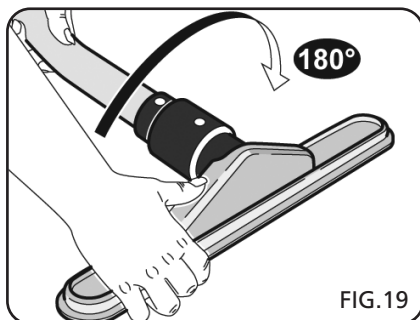

FIG.19

9. OPERATION AND USE

9.1 FOR USE AS A DRY VACUUM CLEANER (FIG.20):

Important: The cartridge filter (13) and bag must always be used.

- Keep the cartridge filter clean.
- Replace the cartridge filter if overly caked or worn.

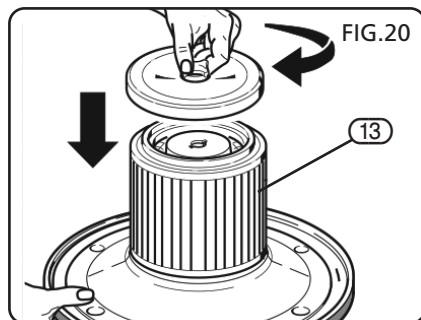

9.2 FOR USE AS A WET VACUUM CLEANER (FIGS.21 – 22):

Important: Always remove the cartridge filter and the paper bag.

- Fit the foam filter (12).

Note: When the vacuumed liquids reach the maximum level inside the drum, suction is automatically cut off by the safety float. The user is alerted by an increase in the pitch rate of the motor sound and by the lack of suction.

- Turn off the appliance immediately and empty the drum.

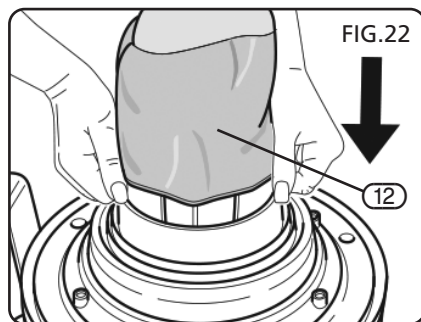
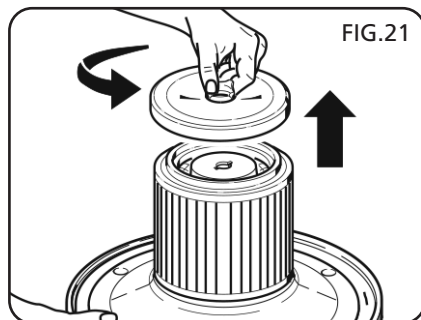

9.3 TO VACUUM LARGE QUANTITIES OF LIQUID (FIG.23):

To ensure partial air flow, make sure that the crevice tool (10) is used and never fully submerged.

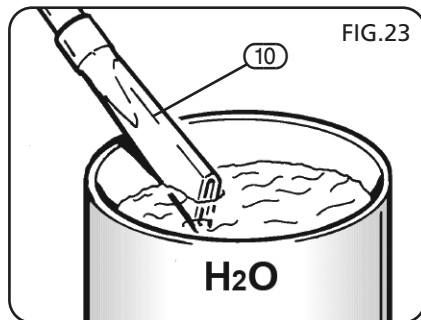

9. OPERATION AND USE

9.4 USING THE VACUUM CLEANER WITH A POWER TOOL (FIGS.25 – 30):

Important: The cartridge filter and filter bag must always be used.

- Remove the foam (12) filter if installed.

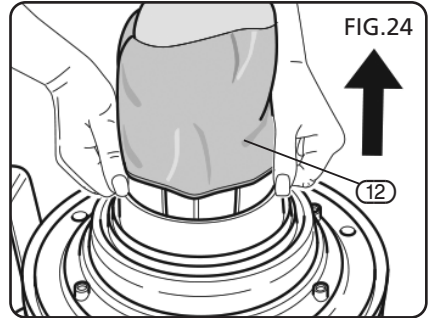

- Fit the bag (14)
- Fit the cartridge filter (13) .
- Fit the plastic disc (13.1) onto the filter.

Always keep the filter system in good working order to ensure efficient operation. We recommend cleaning the cartridge filter frequently as illustrated on P.21.

- Keep the cartridge filter clean.
- Replace the cartridge filter if overly caked or worn.

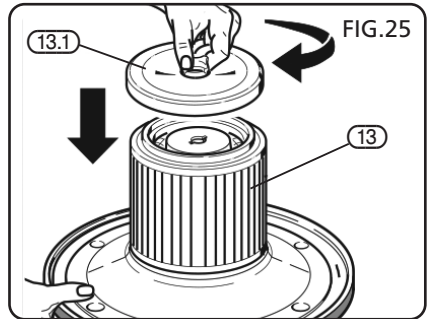

- Attach the connector of the flexible hose (5.2) to the air inlet connector (3).

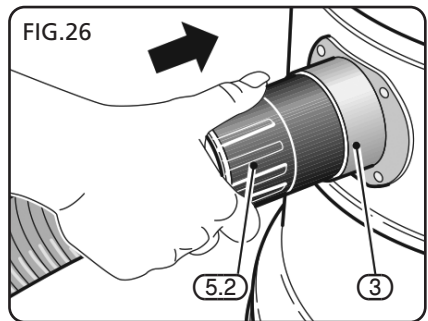

- If required, fit the supplied reducing adaptor (11) onto the end of the flexible hose and connect to the dust extraction outlet of the power tool.

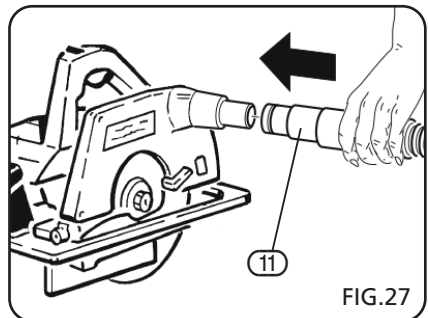

9. OPERATION AND USE

- Plug in the power tool.

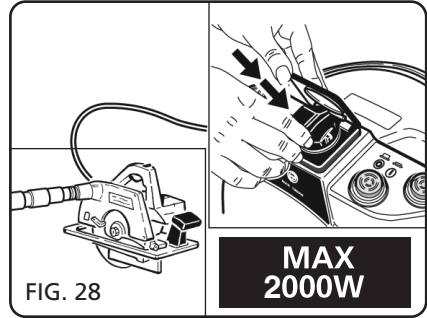

- Plug in the vacuum cleaner.

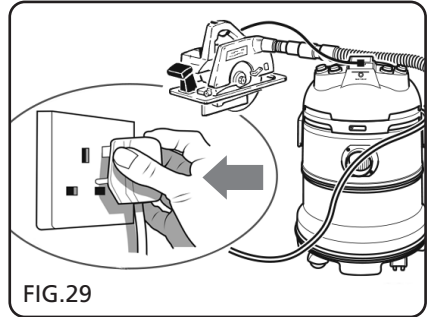

- Using the supplied cable rings (5.1), fix the cable of the electric power tool to the flexible hose.

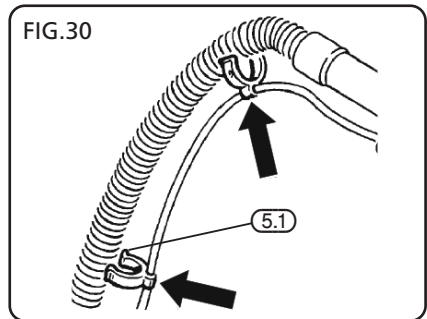

10. MAINTENANCE

Warning: Always unplug the appliance from the power supply before cleaning or servicing the filter system in any way.

Ensure you always wear a FFP3 approved dust mask and open/empty the machine away from other people preferably outside.

10.1 CHANGING THE DUSTBAG (FIGS.31 – 33):

Warning: The paper bag (14) must never be re-used but only be replaced.

– Remove the plastic flange (14.1) from the air inlet connector.

– Take out the full bag.

– Close the plastic flange with the cap provided.

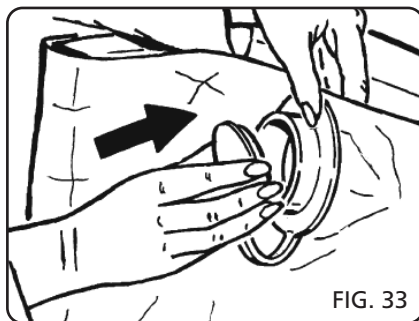
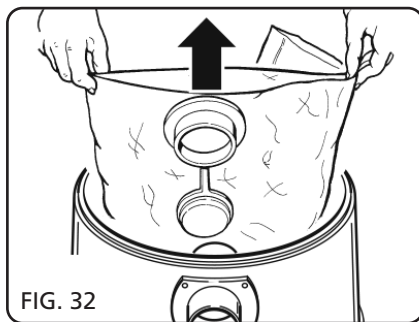
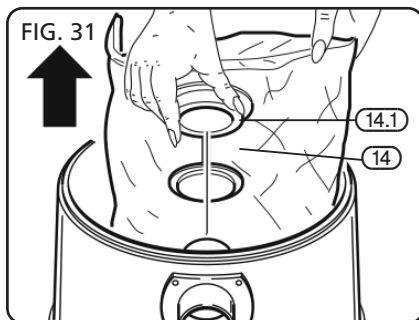

10.2 CLEANING THE FOAM FILTER (FIG.34):

Rinse the foam filter (12) with water. **DO NOT** use detergent.

– Replace if worn or torn.

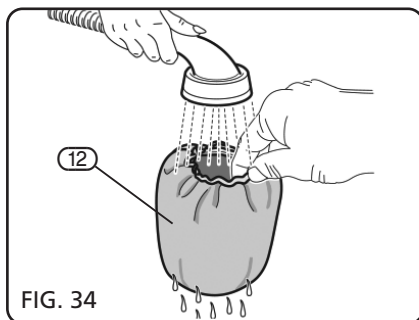

10. MAINTENANCE

10.3 CLEANING THE CARTRIDGE FILTER (FIGS.35 – 39):

To clean the cartridge filter;

- turn on the Self-Cleaning Filter function by pressing the orange switch (D) for approximately 30 seconds.
- Release the button for 15 seconds for the coil to cool down.
- Switch (B) in position (C) = Self-Cleaning Filter function disabled.

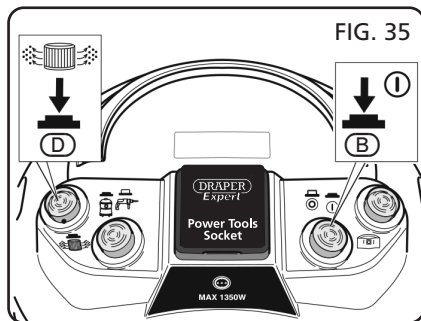

To thoroughly clean the filter;

- Remove the plastic disc (13.1).
- Remove the cartridge filter from the vacuum cleaner.

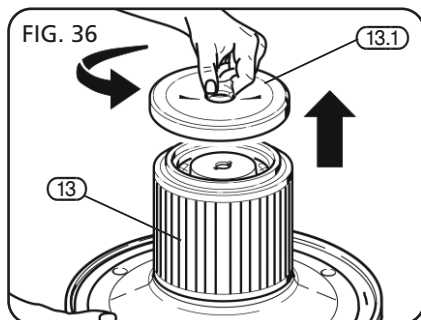

- brush off any loose debris with a suitable soft brush.

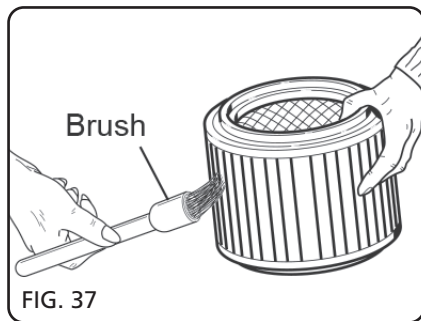

- Rinse under cold water as shown in fig.38.
- Before putting the cartridge filter back on, make sure it is completely dry.
- Replace the cartridge filter **ONLY** if it becomes worn.



10. MAINTENANCE

Important: Handle the cartridge filter carefully when wet.

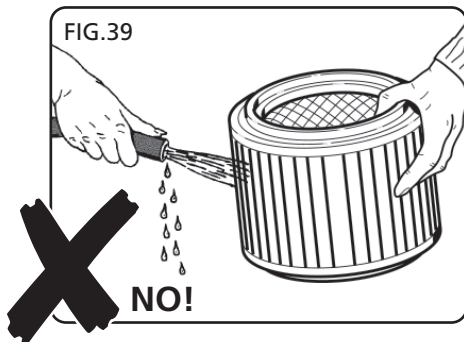

10.4 CLEANING THE DRUM (FIG.40):

To clean the drum;

- Wipe dust out drum when changing bags.
- Change bags when $\frac{3}{4}$ full.
- Dry off the drum and accessories after vacuuming liquids.

10.5 REPLACING THE POWER CORD:

Contact our technical service centre if the power cord has been damaged, since special tools are needed to replace it.

11. TROUBLESHOOTING

Problem	Probable cause	Suggested remedy
The appliance will not start.	No power. Defective power cord, switches, or motor.	Check that the power socket is working. Contact your technical service centre (see attached list).
Reduced efficiency.	Bag full. Cartridge filter is dirty or caked. Clogged tube or accessories.	Replace bag. Thoroughly clean or change the cartridge filter. Check the hose or accessories.
The pitch rate of the motor is noticeably higher.	Bag full. Cartridge filter is dirty or caked. Clogged tube or accessories.	Replace bag. Thoroughly clean or change the cartridge filter. Check the hose or accessories.
The appliance will not start in "power tool" mode.	Defective circuit board.	Contact our technical service centre.

12. EXPLANATION OF SYMBOLS

9.1 EXPLANATION OF SYMBOLS



WEEE

Do not dispose of Waste Electrical & Electronic Equipment in with domestic rubbish.



This logo indicates that this appliance is compliant with 'M' Class approved filtration standards and is suitable for:
Vacuuming dust and liquids.

- Professional use (e.g. hotels, schools, hospitals, factories, shops, offices and rental agencies).
- Dust separation **ONLY FOR DRY** (provided not explosive, flammable, carcinogenic and/or pathogenic) with a limit value of occupational exposure of equal or greater than $0.1\text{mg}/\text{m}^3$ (class 'M').
-

13. DISPOSAL

13.1 DISPOSAL

- At the end of the machine's working life, or when it can no longer be repaired, ensure that it is disposed of according to national regulations.
- Contact your local authority for details of collection schemes in your area.

In all circumstances:

- Do not dispose of power tools with domestic waste.
- Do not incinerate.
- Do not abandon in the environment.
- Do not dispose of WEEE* as unsorted municipal waste.



* Waste Electrical & Electronic Equipment.

- **DRAPER TOOLS LIMITED,**
Hursley Road, Chandler's Ford,
Eastleigh, Hampshire. SO53 1YF. U.K.
- **Helpline:** (023) 8049 4344
- **Sales Desk:** (023) 8049 4333
- **Website:** www.drapertools.com
- **E-mail:** sales@drapertools.com
- **Sales Fax:** (023) 8049 4209
- **General Enquiries:** (023) 8026 6355
- **Service/Warranty Repair Agent**
For aftersales servicing or warranty repairs, please
contact the Draper Tools Helpline for details of an
agent in your local area.

YOUR DRAPER STOCKIST